



**PRO STOCK
ELECTRONIC FUEL
INJECTION
TECHNICAL
DOCUMENTATION**

Table of Contents

• Table of Contents	1
• NHRA Pro Stock EFI Requirements	2
• K&N Pro Stock EFI Air Intake Assembly	5
○ K&N Air Induction System Update and Requirements	6
○ Assembly Drawings	7
• Holley NHRA Pro Stock EFI Parts List	11
• Holley EFI HP ECU Features, Specifications, Manuals and Diagrams	14
○ Holley NHRA Pro Stock Holley EFI HP ECU Features	15
○ Key Software Features	16
○ NHRA Pro Stock EFI Systems Manual	17
○ Holley EFI Wiring Manual and Diagrams	21
• Injector Flow Matching Example	63
• Throttle Body Dimensional Specifications	65
• Mandated Sensor and Harness Specifications	68
○ CAM Sync Signal Sensor	69
○ Coil-Near-Plug Smart Coil	73
○ Hall Effect Crankshaft Signal Sensor	79
○ Holley EFI 36-1 Tooth Crank Trigger System	81
○ HP EFI Smart Coil Sub Harness	82
○ Input/Output Auxiliary Harness	84
○ Pressure Transducer	85
○ Injector Bung Installation	86
• EFI CAN Communications	88
○ Holley EFI CAN Connector Kit	89
○ HEFI 3 rd Party CAN Communications Protocol	90
○ Holley 3 rd Party Protocol Decoder	93
○ 3 rd Party CAN Capture	95
• Five Star Fabrication Hood Components	97
○ Filler Panels and Universal Cowl	98

**NHRA Pro Stock
Electronic Fuel
Injection
Requirements**

NHRA Pro Stock Electronic Fuel Injection Requirements

- **Engine Control Unit:**
 - Holley HP ECU – P/N 554-129 mandatory
 - [Must run NHRA-spec V6 Firmware](#)
 - [Without 3.5in screen: HEFI_06000404_PROSTOCK.eep.](#)
 - [Using 3.5in screen: HEFI-ProStock_06004040.fwu](#)
 - EFI closed loop functionality permitted
 - **Rev Limiter:**
 - NHRA hard limiter set to 10,500 rpm
 - Teams have the ability to set soft limiter to desired rpm level
- **Throttle Body:**
 - Holley – P/N 112-123 mandatory (25 sq. inches)
 - Must be mounted forward facing and remain in the engine compartment
- **Fuel Delivery System:**
 - 90 psi Max
 - Fuel rails and fuel lines must be placed external to the manifold assembly and cannot be built into or be an integral part of the manifold assembly.
 - Fuel can only be distributed into the engine through the 8 NHRA approved Holley injectors
 - Earl's Performance Dry Break Coupler – P/N JV270204RL mandatory
 - Coupler must be remotely mounted on the fuel line between the fuel pressure regulator and fuel rail
 - Coupler must be easily accessible by NHRA Technical Department
- **Hoods:**
 - Must be original OEM design, any variations to the hood must be submitted by the OEM and accepted by NHRA Technical Department prior to running in competition
 - Maximum hood height from ground will be determined at a later date
- **Air Intake:**
 - K&N supplied NHRA Pro Stock Air Induction System (Part Number 100-8522) mandatory, consisting of the following assemblies:
 - Throttle Body Adapter – P/N 088049
 - Coupler; Pro Stock Air Induction Small – P/N 08665
 - Inlet Duct; Pro Stock – P/N 05875
 - Coupler; Pro Stock Air Induction Large – P/N 08641
 - Air Induction Airbox; Pro Stock – P/N 05876
- **Sensors (mandatory):**
 - Holley Hall Effect Crank Sensor Holley – P/N 554-118 or 556-113
 - Holley Hall Effect CAM Sensor Holley – P/N 554-127
- **Fuel Injectors:**
 - Holley EFI Pro Stock Injector mandatory
 - Holley P/N 522-568 (160-pound p/hour) with injector marking 0280158334 and AZNU 90/2000
 - Holley P/N 522-588 (80-pound p/hour) injector marking 0280158051

- Maximum of 8 injectors permitted
- Injector tips may not be modified, and diffuser plates may not be added
- Use of standard Holley supplied extenders only permitted
- Holley HP Smart Coil-Near-Plug Smart Coil (8 ea.) Holley – P/N 556-112 mandatory
- Must be mounted externally on intake manifold runners. No part of the injector or injector opening may be on or above the runner flange into the plenum area. See drawing below

● **Intake Manifold:**

- Intake manifold plenum must be free & clear of any diffusers **or buffers**. Including but not limited to air foils, baffles, **sponges, dividers and or** screens.
- Surface of plenum area must remain smooth
- **Intake manifold is limited to single plane with open plenum design.**
- **Floor or base of plenum floor may be flat or recessed V design.**
- **All manifolds are subject to inspection and acceptance by NHRA Tech Dept.**

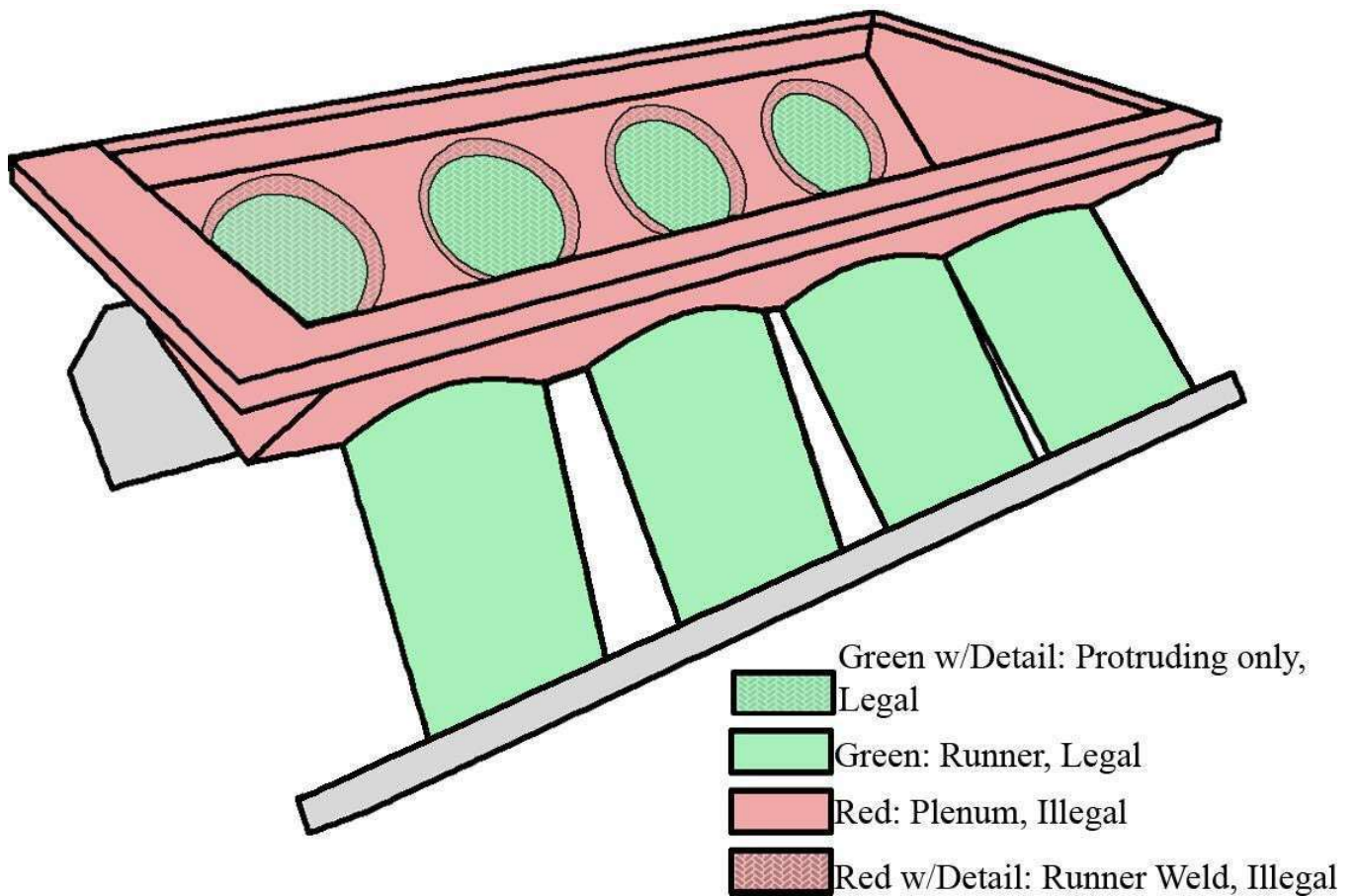

For additional information or questions please contact Lonnie Grim at lgrim@nhra.com or 626-516-9347



K&N
Pro Stock EFI
Air Intake Assembly

K&N Air Induction System Update and Requirements

K&N is now accepting orders for the Pro Stock Mandated Air Induction System (K&N Part Number 100-8522). To place your orders please contact Johnathan Fiello K&N Engineering, Director of Product Development and Engineering directly:

Jonathan Fiello
951-826-4000 ext. 4415
951-826-4142 fax
jonathanf@knfilters.com

Parts will be available beginning today, however, orders will be filled based first on final points earned during the 2015 season, then to teams completing in either the Circle K NHRA Winternationals in Pomona and/or the CARQUEST Auto Parts NHRA Nationals in Phoenix. K&N expect to have sufficient inventory to supply all orders by the end of the first week of January 2016.

Please note that the NHRA Pro Stock Air Induction System (K&N Part Number 100-8522) is the only accepted system for all cars competing in the NHRA Pro Stock Class. All components supplied with this system are the only accepted parts for use, NO substitutions. Parts may NOT be modified with the exception of the Air Induction Airbox, P/N 05876. This part may be trimmed on the front side to allow it to seal up against the front end of the car in the lower grille area. Flanges may also be installed on the outer edges of this piece to allow Dzus fasteners to be used to help with sealing purposes when the front end is installed on the car. Also the Inlet Duct, P/N 05875 may be trimmed to fit in between the Air Induction Box and the Throttle Body Adapter. All other couplers and throttle body adapter parts provided with this system must be used. This system must be installed on the chassis so as to remain in place when the front end is removed from the car. Insulating or artificial cooling of the system is prohibited.

12/21/2015

2

E

100-8522 NHRA PRO STOCK AIR INDUCTION SYSTEM

3

4

D

5

NOTES: 1. SEE ADDITIONAL SHEETS FOR INDIVIDUAL PART DIMENSIONS.

C

B

ITEM NO.	PART NUMBER	DESCRIPTION	MATERIAL	QTY.
1	088049	THROTTLE BODY ADAPTER	6061-T6 ALUMINUM	1

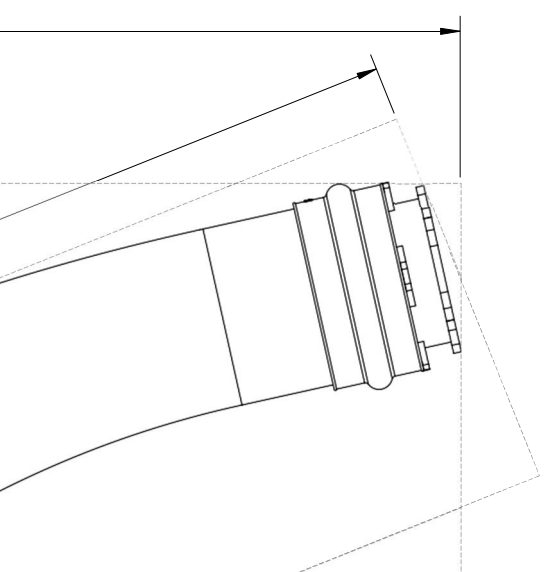
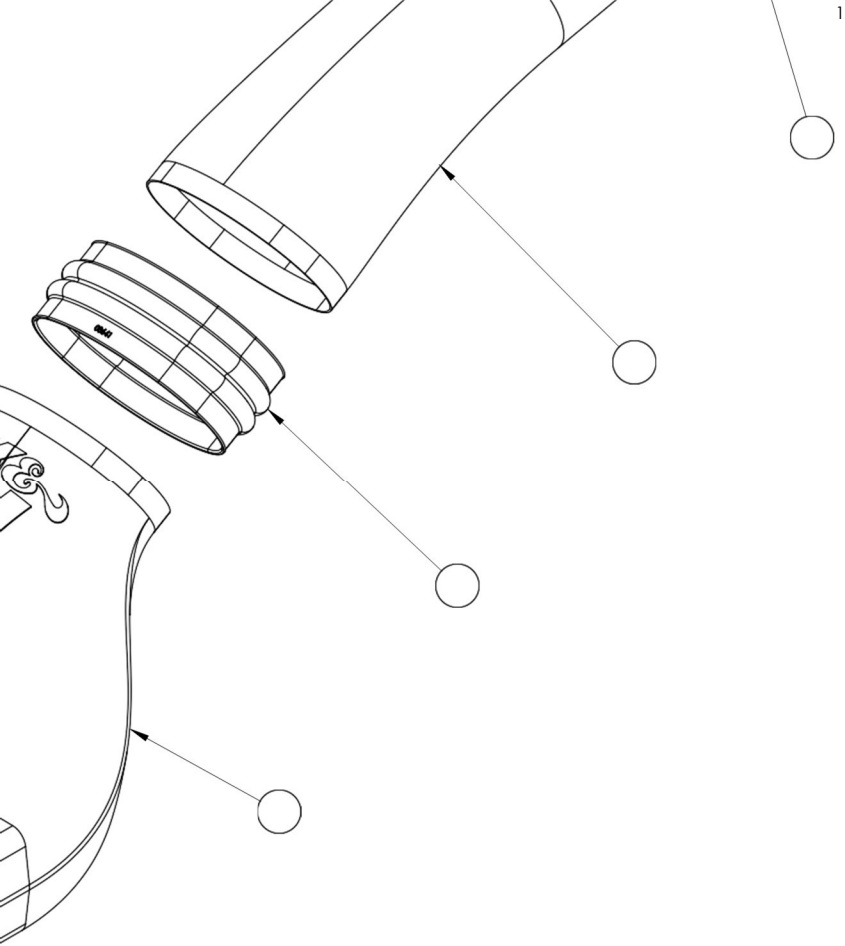

E

D

C

B

9.90

8.00

11.04

5.00

28.09

5.797

9.92

4

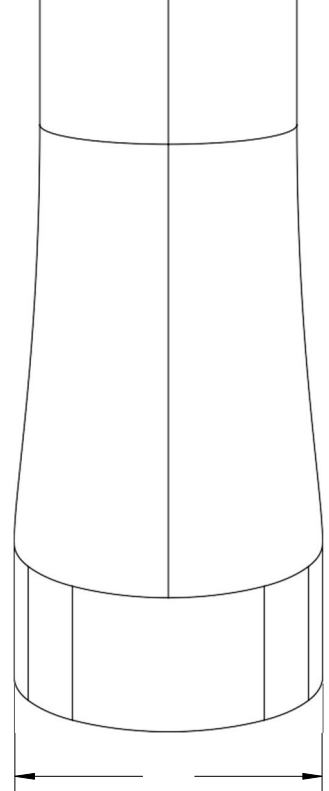

3

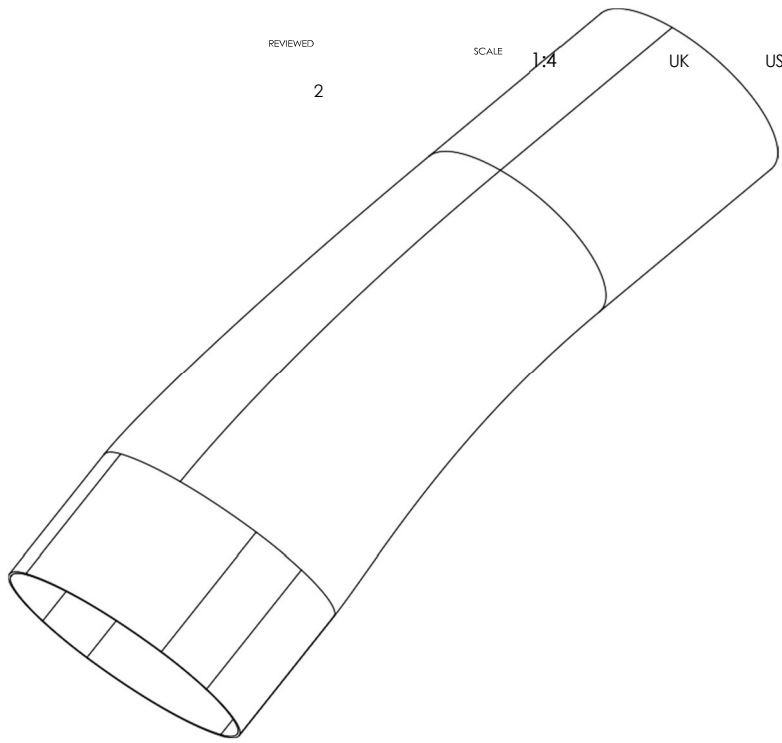

2

1

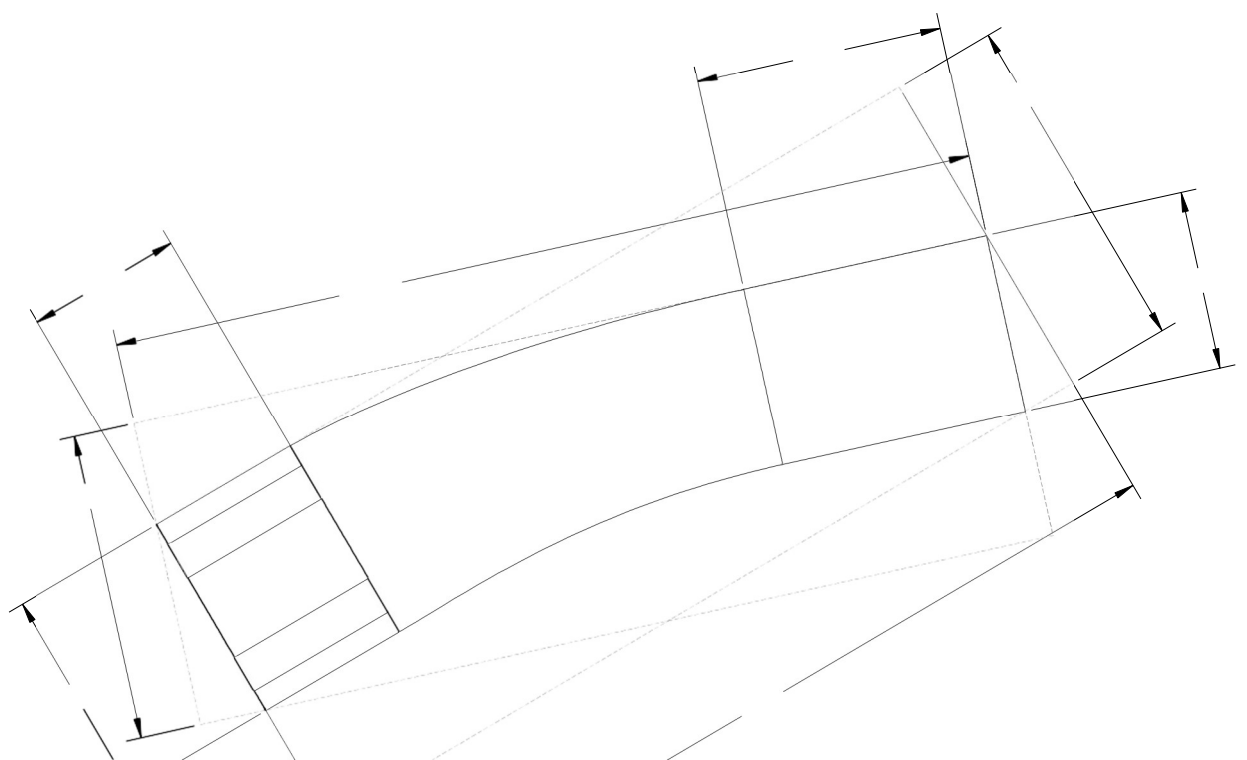
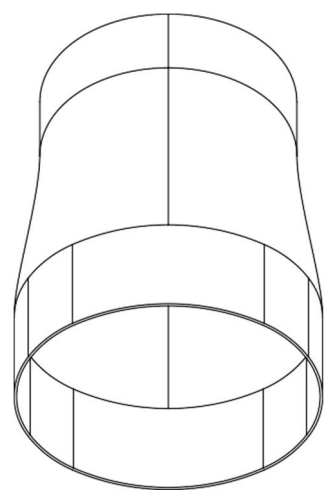

E

D

B

SECTION B-B

C

B

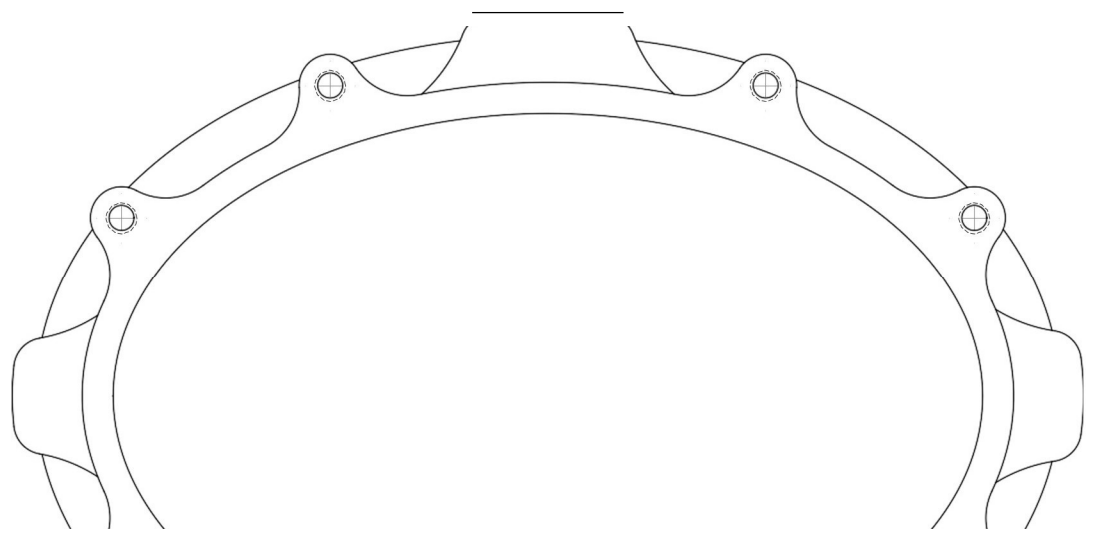
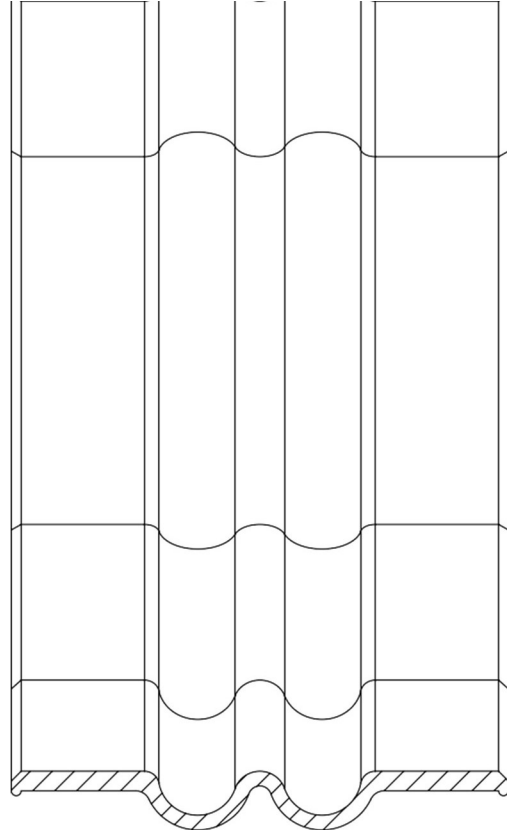
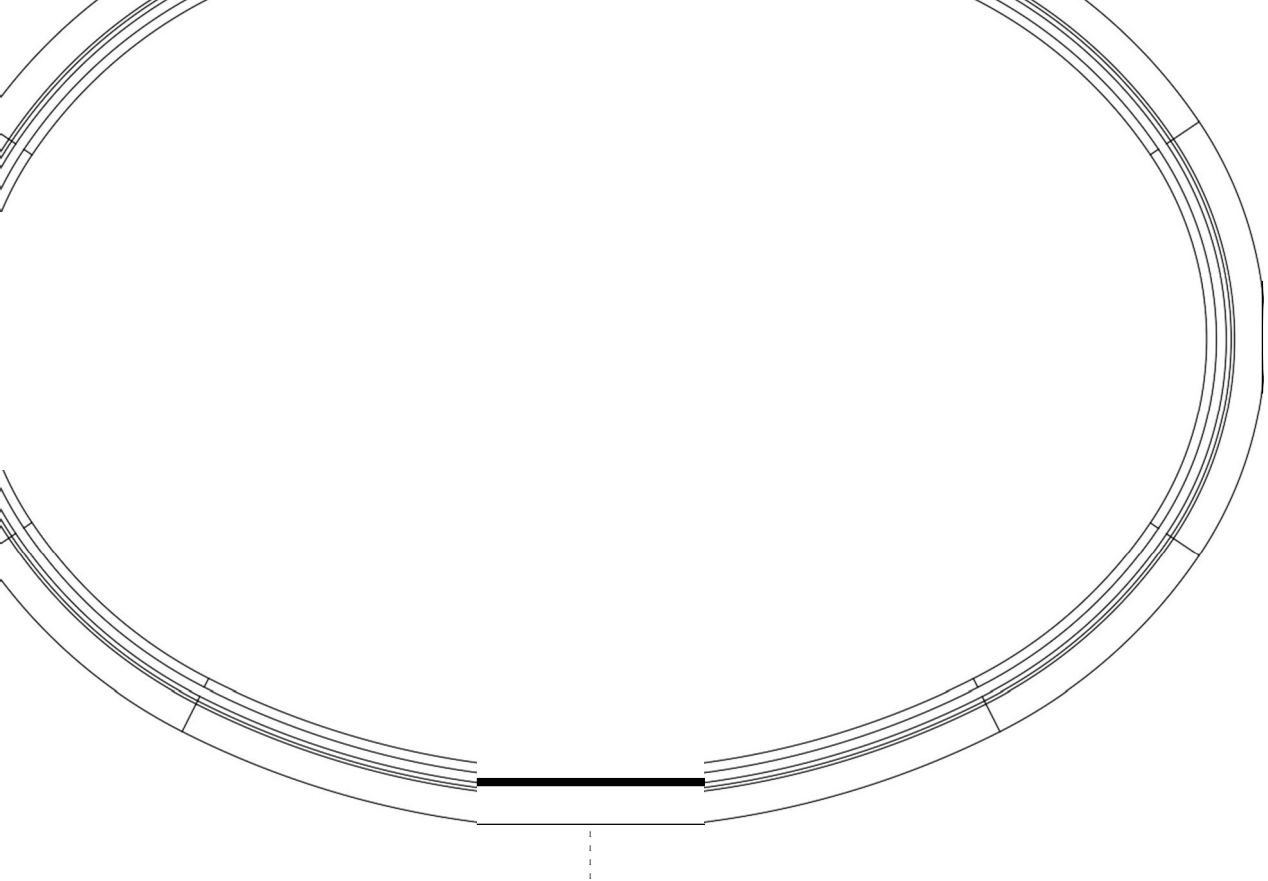

E

D

NOSE LEVEL

C

GROUND LEVEL

B

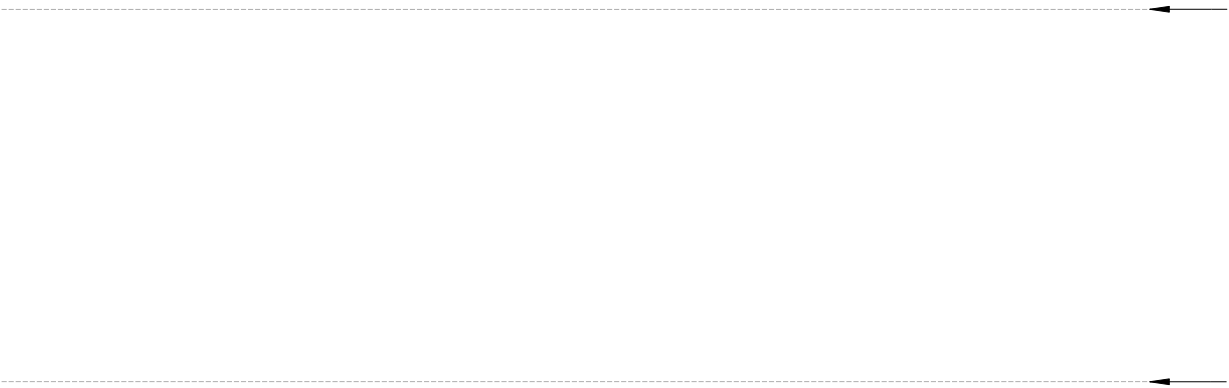
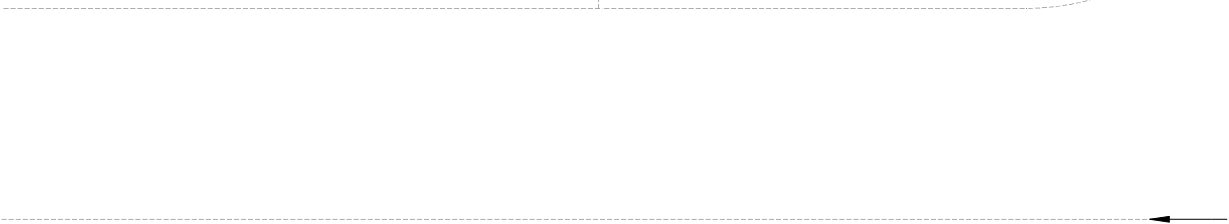

Holley NHRA Pro Stock EFI Parts List

Holley EFI NHRA Pro Stock Parts List

To purchase Holley EFI hardware or questions please contact Robin Lawrence directly at 270-745-9502 (Office), 270-791-6850 (Cell) or RobinLawrence@holley.com

NHRA Spec Components

554-129 Holley EFI NHRA Pro Stock ECU

112-123 Holley EFI NHRA Pro Stock Throttle Body

Pick One

- 522-568 Holley EFI 160 Pound Per Hour Bosch Injectors (Set of 8)
- 522-588 Holley EFI 80 Pound Per Hour Bosch Injectors (Set of 8)

Pick One

- 554-118 Holley Hall Effect crank sensor
- 556-113 Holley 36-1 Tooth crank sensor

554-127 Holley Hall Effect Cam Sensor

556-112 HP Smart Coil (8 Required)

JV270204RL Earls SPH Bayonet Locking Dry Break

554-100 NTK Wideband (Not Required by NHRA)

Recommended Components

558-308 Main Power Harness

Pick One

- 558-104 Universal MPFI Harness, or
- 558-105 Unterminated Main Harness

Pick One

- 558-200 V8 injector harness, or
- 558-204 Unterminated Injector Harness

558-306 Universal Unterminated Ignition, Harness

558-307 Coil Near Plug Harness (Not required if using a 558-105 Unterminated Main Harness)

558-312 HP Smart Coil Sub Harness

Optional Items

9920-107 Air Temp Sensor

534-10 Coolant temp sensor

538-24 1 bar map sensor

534-85 (8) injectors bungs

534-207 (2) Universal 18" fuel rails will need machined

558-400 8 Pin Input/output Connector

554-102, 100 PSI Pressure Sensor

558-412 CAN to Racepak and Other external CAN Device

Updated 12/22/2015

Holley EFI HP ECU Features, Specifications, Manuals and Diagrams



NHRA Pro Stock Holley EFI HP ECU Features

- Eight 8:2 or 4:1 amp sequentially driven injector drivers
- Eight channel “smart coil” ignition driver outputs. Can drive 2 wire “dumb coils” with add on module
- Crank and Cam inputs compatible with VR or Hall effect sensors
- Compatible with the following crank sensor inputs
 - 60-2
 - 36-1
 - 24-1
 - 12-1
 - 1 pulse per fire
- Integrated wide band oxygen sensor (NTK or Bosch)
- ECU fully potted for vibration resistance and thermal
- Sealed automotive/marine grade connectors
- 4 GB internal data logging memory
- Two channel knock inputs (single or two wire sensors)
- Four user configurable inputs:
 - Two configurable as Frequency, 0-5 volt analog, or ground trigger
 - Two configurable as Frequency, 0-5 volt analog, 0-20 volt analog, thermistor, 12v trigger, or ground trigger
- Four user configurable outputs:
 - Two configurable as switched 12v output or PWM+ output
 - Two configurable as ground output or PWM- output
- Dedicated fuel and oil pressure inputs
- 1-5 Bar MAP sensor compatibility
- Compatible with most domestic OEM sensors and can be custom configured for any sensor
- Single CAN output channel



KEY SOFTWARE FEATURES

- Intuitive software and features designed for novice and veteran tuners
- Capable of driving low and high impedance injectors with multiple strategies.
- Simple to use but powerful idle control, temperature and acceleration enrichment strategies
- Speed Density, Alpha-N or Alpha-N/Speed Density combination fueling strategies
- Base Fuel Table units can be programmed as either lbs/hr of fuel or engine VE.
- Fuel table can be set to 31x31 or 16x16 with user adjustable axes.
- Timing table can be set to 31x31 or 16x16 with user adjustable axes.
- 16x16 Individual cylinder fueling tables with user adjustable axes.
- 16x16 Individual cylinder timing tables with user adjustable axes.
- 16x16 Coil dwell table
- 16x16 Injector end angle table with automated "Injector Auto-Phasing" calculation table
- Three programmable timing retards with user programmable Time or RPM scales. Activated by input or input release
- Advanced ICF functionality allows *Per-Gear* Timing and Fuel tuning along with countless other modifications based on almost any input, output or sensor value.
 - Eight "1D" 1x16 Tables
 - Eight "2D" 16x16 Tables
 - Four "1D" 1x16 Gear Based Tables (up to 8 gears)
 - Four "2D" 16x16 Gear Based Tables (up to 8 gears)
 - Tables can be activated/deactivated based on multiple conditions
 - User defined axes (units and scaling)
- Fuel map and learn function smoothing
- 16x16 Target Air/Fuel Ratio table
- Fully adjustable closed loop and fuel table learn parameters
- Magnetic and hall effect crank utilizing one pulse/fire, 12-1, 24-1, 36-1, 60-2, & GM 24X/58X signals
- Hall effect and magnetic cam triggers utilizing single pulse & GM 4X signals
- 1-7 bar MAP sensor capability
- Allows for use of common OEM sensors as well as customer sensor calibration input
- Dedicated fuel and oil pressure inputs
- Internal data-logging standard (up to 100hz) with 4 GB of memory
- Plug and Play with Holley EFI Digital Dash (553-106)
- Fully Configurable laptop Gauge Panel
- CAN interface output to Racepak V-Net
- Fully featured data-log review software
- Data-logger software with, scalable axes, smoothing, multiple graph view ability, math channels, pre-defined notes fields and many more
- Strip Chart Real-Time Data Viewer
- Distributorless ignition (DIS) outputs capable of directly driving "smart" ignition coils or Holley DIS coils. Drivers will control 2 wire coils such as Modular Ford and Chrysler HEMI
- Drag-and-drop software pin mapping
- 4 programmable pulse width modulated (PWM) outputs (2 high and 2 low) and 4 fully configurable inputs
- Inputs can be programmed as speed/frequency, 0-5v, 0-20v, thermistor, or switched high or low.
- Outputs can be triggered by switched, sensor inputs, or multiple inputs with logic conditions.
- Multiple Outputs can be linked together based upon single input conditions.
- User Programmer caution and warning outputs for all sensors
- Configurable user password protection



NHRA® PRO STOCK EFI SYSTEMS MANUAL

NOTE: Teams should be provided with a multitude of instruction manuals for all Holley EFI products in their NHRA packets. These manuals are intended to be used for detailed information, this manual reviews areas specific to Pro Stock applications and important points. These manuals are also available on www.holley.com by typing in a part number which will have any instruction manuals present. Others can be found on www.holley.com in "Support", "Tech Service", "Resource Documents and Library", and "Fuel Injection". Also, various EFI manuals and information are found in the help section in the EFI software under "Help" and "Contents".

1. ECU Mounting

The ECU is to be mounted in the interior area, where it can be easily viewed by technical personal to validate that the unit is marked as a Holley EFI Pro Stock ECU.

The ECU should be mounted in one of two ways:

- 1) Using the hardware included. The ECU should retain the plastic and rubber grommets that are pre-installed on the ECU.
- 2) Remove the plastic and rubber grommets and use a typical rubber isolator mount (**Figure 1**).



Figure 1

NOTE: If the USB mounting cable is left attached to the ECU at all times, it is advised to wire tie the USB cable to something near the ECU (strain relief the cable). If a laptop is removed and the USB cable is accidentally left attached, it won't pull and damage the USB connector at the ECU.

2. Wiring Installation

The most important part of an EFI installation is the wiring installation. It MUST be done in a proper manner, with proper care, and with the proper tools. If it is not, intermittent problems are likely to surface, which are not only a huge headache and frustration to diagnose, but can cost you a race. Electronics must have a clean and consistent power source, with proper voltages when the car is starting and running. The battery must be of proper size and in good condition. The battery used must be capable of supplying consistent voltage to the complete fuel injection system at all times. If not, the performance may be degraded or inconsistent. The EFI following is the approximate current draws for the system:

- 1) Injectors – 8A
- 2) ECU – 5A
- 3) WBO2 Sensor – 8A
- 4) Ignition Coils – 15-40A (depending on the dwell setting) – it is recommended to run either a single 70A or dual 40A relays to feed ignition coils.

Main Power Harness

The main ECU power harness is the lifeblood for the ECU and must be connected in a manner, so that it is removed from “noisy” items such as cooling fans and fuel pumps. The ECU has a main power and ground harness (PN 558-308). It is very important that these connections are tied to “clean” locations. The following is where these need to be connected:

- Ground (10ga Black) – Connect directly to the negative battery post. **DO NOT USE THE CHASSIS/ROLL CAGE AS THIS PATH.**
- Power (10ga Red) – Connect directly to the battery cutoff switch on the cutoff side (such that this wire will not have power when the switch is “OFF”).

IMPORTANT! Terminals are included with the main power harness (wires are 10 gauge). Make sure the terminals are crimped on with a high quality crimping tool and covered in the included heat shrink.

Vehicle Grounding

IMPORTANT NOTES:

A ground cable should be run from the battery all the way to the cylinder head (or less ideally, the block), as this is the ground path back to the battery for the ignition. In other words, don't use the chassis/cage for grounds for the EFI, or for grounding the engine back to the battery. Use a minimum of a 2 gauge cable for this purpose. It is also a good idea to run a ground loop (10ga) from head to head. **IT IS ADVISED NOT TO USE THE CHASSIS/ROLL CAGE FOR ANY EFI RELATED GROUNDS, AS WELL AS DON'T GROUND THE ENGINE TO THE BATTERY VIA THE CHASSIS/CAGE.**

3. Main Harness

Holley instruction manual PN 199R10555 (“Wiring Manual & Diagrams”) contains information and schematics on wiring Holley EFI systems. This file can also be found in the software help section (“Help” and “Contents” and then “Wiring Manuals and Diagrams”). Also found there is the “Wiring Quick View” section where wiring diagrams can be saved and opened and viewed (and zoomed and printed).

If using a Holley harness, there are two main options to make a harness. Most likely, an unterminated harness will be custom fit to the car. One might desire to use a terminated harness for the engine dyno.

The main harness connects into the ECU and contains a 34 pin (“J1A”) and 26 pin (“J1B”) connector.

The first solution uses mostly pre-terminated harnesses:

- PN 558-308 – Main ECU Power Harness
- PN 558-104 – Terminated Main Harness: Main Harness that connects to the ECU. Will need TPS adapter changed.
- PN 558-306 - Unterminated Ignition Harness: Plugs into the 558-104 Ignition Adapter Connection and connects to the crank and cam sensors. User must terminate crank and cam sensor connectors.
- PN 558-200 – Terminated Injector Harness: Plugs into 558-104 Injector Connector
- PN 558-307 – Coil-Near-Plug Harness: Pins plug into the J1B ECU Connector and go to an 8 pin metripak connector that plugs into PN 558-312 harnesses.

- PN 558-312 – Coil Harness: Contains two pre-terminated coil harnesses that plug into the Holley HP Coil-Near-Plug coils (Even and Odd banks). Connects to 558-307 harness.
- PN 558-400 – Input/Output Harness: Plugs into 558-104 Input/Output connector: Used for custom inputs and outputs.

This second solution uses mostly user terminated harnesses:

- PN 558-308 – Main ECU Power Harness
- PN 558-105 – Unterminated Main Harness: ECU J1A and J2A connectors are pinned and connectorized, sensor ends are flying lead. All cavities are populated with all wires so no additional harnesses are needed at the ECU connector.
- PN 558-200 – Terminated Injector Harness **OR** PN 558-204 – Unterminated Injector Harness
- 558-312 - Coil Harness: Contains two pre-terminated coil harnesses that plug into the Holley HP Coil-Near-Plug coils (Even and Odd banks). This is OPTIONAL if the user doesn't want to make a coil harness. The 556-112 coils come with connectors and pins to connect to the 558-105 harness.

Required Tools

The following is information for terminal crimpers for some of the Delphi connectors used on the Holley EFI harnesses mentioned above. All of them are needed for the unterminated harness. PNs are called out for items in the terminated harness solution.

Waytek Wire P/N	Delphi P/N	Terminal	Needed For:
509	12155975	Metripak 150	558-306 and Unterminated
508	12039500	Metripak 150.2	TPS Connector and Unterminated
400	15359996	Metripak GT 150	Unterminated

Pin Removal Tools

Waytek Wire P/N	Delphi P/N	Terminal
422	12094429	Metripak 150 Removal Tool
431	12180559	Metripak GT 150 Removal Tool

Loose Wires

The following are “loose wires” that are 19 inches from the ECU connector in the terminated harness. In the unterminated harness, they in the wire bundle.

NOTE: The fuel pump that will be used will be more than 10 amps, hence will need to be powered independently from the Holley EFI harness. The fuel pump can be run off of a separate switch and relay, or the fuel pump relay trigger from the Holley ECU can be used to trigger a separate fuel pump relay. The Holley fuel pump relay output (Pin J1A-2) operates such that the relay is triggered on key-on for a user programmable amount of time, and if the RPM goes to 0, this output is shut off.

The Holley supplied relay can be used for the injectors, or they can be powered from an existing relay board as long as it meets current requirements.

- 20 Gauge Black – Relay Ground – This provides a ground for the trigger side of the injector relay. If the integrity of this ground source isn't 100%, the fuel pump may fail to operate.
- 14 Gauge Red – Fuel Injector – This provides the high current power for the fuel injectors and has a fuse installed in the harness.

- 14 Gauge Green – This is used to power a fuel pump with less than 10A current draw and shouldn't be used in this application unless it is used to trigger a separate relay.
- 18 Gauge Red/White – Switched Ignition +12V – This wire should be connected to the “ignition toggle switch”. This input is what turns the ECU on and off. It will also activate the injector relay after it is turned on for about 5 seconds (user programmable). After 5 seconds, the relays will be deactivated, and turn back on once an engine RPM signal is present. It is best to hook this wire up directly off the ignition switch.
- 20 Gauge Blue/White – Tachometer Output – ECU Pin J1A-28. This wire provides a 12V square wave tachometer output that is used to send an RPM signal to a conventional tachometer. It is a loose wire in the unterminated harness and is part of the 10 pin ignition adapter connector on the terminated harness.

Coil Wiring

When wiring the 556-112 coils, make sure:

- Pin C (cylinder head grounds), uses no smaller than an 18ga wire individually and each bank of 4 coils should be connected to a 10-12ga wire and grounded directly to the head. It is advised not to loom this with the other coil trigger wires. **NOTE: DO NOT TIE ANY OTHER GROUNDS TO THIS LOCATION**
- Pin E (power) should not use smaller than an 18ga wire on each, and have each bank of 4 coils tied to a 10-12ga wire to the power source – it is recommended to run either a single 70A or dual 40A relays to feed ignition coils.
- Pin D (battery ground) should also not use wire smaller than 18ga on each, and have each bank of 4 coils tied to a 10-12ga wire that is tied back to the battery.

Battery Charging

The following recommended practices when using a battery charger with the EFI:

- NEVER try to start a car with a dead battery and a charger on high current settings
- When charging the car, ideally the battery cutoff switch will be OFF and the ECU not powered

Injector Machining

The following are recommended bore diameters for the intake manifold injector O-ring pockets and fuel rail O-ring pockets.

- Fuel Rail bore: .535" +/- .004
- Intake Manifold bore: .550" +/- .004

Both entries should have a proper chamfer (any sharp edges broken/radiused) so that the o-rings will not be damaged when assembled.

Tuning Information

Instructions and Tuning manuals are included with the Holley software. Go to “Help” and “Contents” to view them. There are two “tuning” manuals there. The “Step-By-Step Beginners Tuning” manual is for people that have no experience with any aftermarket EFI. The “Experienced Users Tuning” manual is for people that have familiarity with aftermarket EFI systems. It goes over basic system setup of Holley EFI.



WIRING MANUAL & DIAGRAMS

199R10555



HP EFI and Dominator EFI Systems

Contents

1.0 Manual Overview.....	3
1.1 Important Wiring “Do’s and Don’ts”.....	3
2.0 ECU Installation, Connectors, and Pinout.....	3
2.1 Pinout.....	5
3.0 Main Harness.....	7
4.0 Primary Sensors.....	7
4.1 Throttle Position Sensor (TPS).....	7
4.2 Manifold Air Pressure Sensor (MAP).....	8
4.3 Coolant Temperature Sensor (CTS).....	8
4.4 Manifold Air Temperature Sensor (MAT).....	8
4.5 Knock Sensor (Knock).....	8
4.6 Wide Band Oxygen Sensor (WB02).....	8
4.7 Fuel Pressure (Fuel).....	8
4.8 Oil Pressure (Oil).....	9
4.9 CANbus (CAN).....	9
5.0 Primary Outputs.....	9
5.1 Idle Air Control (IAC).....	9
5.2 Fuel Injector Outputs (Injectors).....	9
5.3 Ignition Adapter (Ignition).....	10
6.0 Loose Wires.....	10
7.0 Main Power.....	11
7.1 Overview.....	11
8.0 Ignition System Wiring.....	11
8.1 LSx Engines with 24x Crankshaft Reluctor Wheel.....	11
8.2 LSx Engines with 58x Crankshaft Reluctor Wheel.....	11
8.3 Small Cap Computer Controlled GM HEI.....	12
8.4 Ford TFI.....	13
8.5 NON- ECU Controlled Timing Applications (ex. GM Non-ECU Controlled Large Cap HEI).....	15
8.6 Magnetic Crank Pickup.....	17
8.7 Magnetic Cam Pickup.....	18
8.8 Hall Effect Crank Pickup.....	19
8.9 Hall Effect Cam Pickup.....	20
8.10 Holley Distributorless Ignition System (DIS).....	20
9.0 Programmable Inputs and Outputs.....	26
9.1 Inputs.....	26
9.2 Outputs.....	27
10.0 Nitrous System Wiring.....	27
11.0 Water/Methanol System Wiring.....	28
11.1 Required Wiring.....	28
11.2 Optional Wiring.....	29
12.0 Electronic Transmission Wiring.....	29
13.0 Wiring Appendix.....	30

1.0 Manual Overview

This manual contains information and diagrams related to wiring most Holley EFI products including ECU's, ignition systems, nitrous systems, water/methanol injection systems, sensors, and more.

1.1 Important Wiring “Do’s and Don’ts”

An EFI system depends heavily on being supplied a clean and constant voltage source. The grounds of an electrical system are just as important as the power side.

HP and Dominator ECU's both contain multiple processing devices that require clean power and ground sources. The wiring harnesses for them must be installed in such a manner that they are separated from “dirty” power and ground sources.

DO’S

- Install the main power and ground directly to the battery.
- Keep sensor wiring away from high voltage or “noisy/dirty” components and wiring, especially secondary ignition wiring, ignition boxes and associated wiring.
- Use shielded/grounded cable that is supplied for wiring crankshaft and camshaft signals.
- Properly solder and heat shrink any wire connections.
- It is critical that the engine has a proper ground connection to the battery and chassis.
- On GM LSx engines, always install the black “ignition ground” wire in the harness to the engine block or cylinder head.

DON'TS

- DO NOT EVER run high voltage or “noisy/dirty” wires in parallel (bundle/loom together) with any EFI sensor wiring. If wires need to cross, try to do so at an angle.
- Do not let Crank and Cam signal wiring near spark plugs and coil wires.
- Do not run non-shielded/grounded wire for crankshaft and camshaft signals, especially magnetic pickups.
- Do not run the USB Communications cable near or with any noisy wires.
- Do not exceed the current limits provided for the various outputs. If current levels exceed these, use the appropriate relay or solenoid drivers.
- Do not use improper crimping tools.
- Don't use things like “t-taps”, etc. Use solder and heat shrink.
- It is never recommended to splice/share signal wires (such as TPS, etc) between different electronic control units.
- Don't wire items that require “clean” ground or power to the same points.

2.0 ECU Installation, Connectors, and Pinout

ECU Mounting – The ECU is packaged with mounting hardware. This hardware includes stainless steel fasteners and locknuts and vibration absorbers. The vibration absorbers should be mounted between the ECU and mounting surface. If the mounting surface isn't flat, don't over-tighten the mounting screws.

Battery Power Connection – Both the HP and the Dominator ECU's share the same main battery power connector. Looking at the front, this connector is at the far right side. The bottom position, Terminal “A” is the ground. The upper position, Terminal “B” is the positive terminal. Always use the fused power cable with the proper connectors supplied by Holley only.

USB Communications Connector – Both the HP and Dominator ECU's share the same USB connector. Looking at the front, the connector is at the far left side. This connection is a common “mini USB” connector, typically used for digital cameras and other devices. Holley offers a USB cable with a sealed connector, PN 558-409 for applications where the USB cable will be plugged in, and the ECU is mounted in a dirty environment.

HP ECU – The HP ECU has **two** main connectors:

- **P1A** - The first connector next to the USB connector is the “P1A” connector (34 pin). This connector is primarily an “Input” connector. It contains all the sensor inputs and wide band oxygen sensor control.
- **P1B** - The second connector is the “P1B” connector (26 pin). This connector is the “output” connector. It has 8 injector outputs, 8 DIS ignition outputs, 4 IAC outputs, and 4 user programmable outputs.



Figure 1

Dominator ECU – The Dominator ECU contains the same two main connectors that the HP ECU has - P1A and P1B. The main wiring harnesses are identical between the two, meaning a Dominator ECU can be installed in place of an HP ECU.

The Dominator ECU has **four** additional connectors that the HP does not. They are as follows and are seen on Figure 2.

1. **P2A** – The P2A connector is an “Input” connector for the following purposes:
 - #2 wide band oxygen sensor input
 - A variety of user programmable inputs.
2. **P2B** – The P2B connector is an “Output” connector for the following purposes:
 - Four additional injector driver outputs.
 - Four Additional coil driver outputs
 - A variety of user programmable outputs.
3. **P3** – The P3 connector contains the following:
 - Intended for use for Drive By Wire throttle body operation
 - It contains a dedicated pin for the “multi-map selector”. (PN 558-407)
 - Contains a variety of user programmable inputs and outputs
4. **P4** – The P4 connector is intended for electronic transmission control for GM 4L60-80E transmissions. If an electronic transmission is not used, all the pins (which contain various input and output options) or open for use as user configurable selections.

NOTE: All connectors are keyed differently, so it is not possible to install them incorrectly.

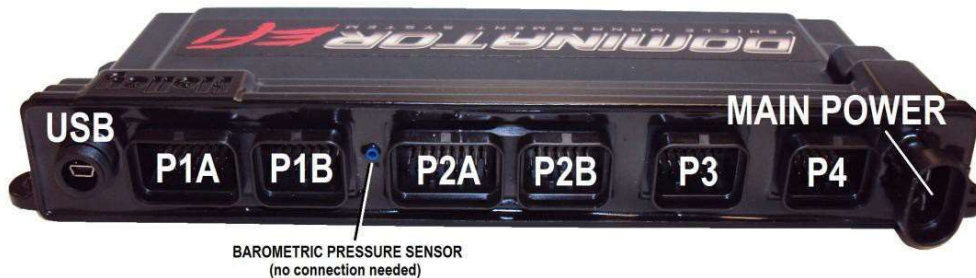

Figure 2

Purchasing Connectors

The P2A, P2B, P3, and P4 can be purchased in two different manners. Each can be purchased individually. These kits contain the connector as well as all the wires that would be populated into them. The wires have the pins properly crimped onto them, but are not inserted into the connector. The second method is to purchase a kit which has all the connectors and pins, but does not have any wiring.

The PN's are as follows:

558-401 – P2A Auxiliary Harness - Contains connector and loose wires with crimped pins. It also contains the #2 WB02 sensor input which is properly wired and terminated into connector.

558-402 – P2B Auxiliary Harness – Contains connector and loose wires with crimped pins.

558-403 – P3 Auxiliary Harness - Contains connector and loose wires with crimped pins.

558-401 – P4 Auxiliary Harness - Contains connector and loose wires with crimped pins.

558-402 – GM 4L60/80E Transmission Harness – Complete terminated harness with P4 connector to operate GM electronic transmissions.

558-403 – GM Drive By Wire Harness – Complete terminated harness with P3 connector to operate late GM drive by wire systems.

558-408 – P2A, P2B, P3, P4 Connector and Pin Kit – Contains connectors and pins, but no wiring.

NOTE: When referring to the harness, the various connectors are designated with a “P”. When referring to the ECU, the connectors are designated with a “J”. They both refer to the same connection point.

2.1 Pinout

The following is a pinout of all connectors.

The P1A and P1B connectors and pinout are identical for the HP and Dominator ECU's.

P1A Connector

Pin	Function
A1	Coil - Input
A2	Fuel Pump Out (+12v) (10A Max)
A3	Input #2 (F52THG)
A4	Input #4 (F5G)
A5	TPS Input
A6	Points Trigger Output
A7	WB1 COMPR2
A8	WB1 Shield
A9	WB HTR -
A10	Switched +12v Input
A11	Manifold Air Temp Input
A12	Input #1 (F52THG)
A13	Input #3 (F5G)
A14	Cam/Crank Ground
A15	Gauge Digital Output
A16	WB1 COMPR1
A17	WB1 VS-/IP+
A18	Sensor Ground
A19	Engine Coolant Temp Input
A20	Oil Pressure Input
A21	Knock #2 Input
A22	Cam Sync Input / Ignition Bypass Output
A23	Map Sensor Input
A24	CAN Lo
A25	WB1 VS+
A26	Sensor +5v
A27	NOT USED
A28	EST/Spout Output
A29	Knock #1 Input
A30	Crank Speed Input
A31	Fuel Pressure Input
A32	CAN Hi
A33	WB1 IP+
A34	WB HTR +

P1B Connector

Pin	Function
B1	IAC A Lo
B2	IAC A Hi
B3	Output #4 (G P-)
B4	Injector F Output
B5	Injector G Output
B6	Injector H Output
B7	Injector E Output
B8	IAC B Lo
B9	IAC B Hi
B10	Output #3 (G P-)
B11	Output #2 (H P+)
B12	Output #1 (H P+)
B13	Injector D Output
B14	EST Ground Output
B15	EST 2 Output (Cylinder #2)
B16	EST 4 Output (Cylinder #4)
B17	EST 6 Output (Cylinder #6)
B18	EST 8 Output (Cylinder #8)
B19	Injector A Output
B20	EST 12V Output
B21	EST 1 Output (Cylinder #1)
B22	EST 3 Output (Cylinder #3)
B23	EST 5 Output (Cylinder #5)
B24	EST 7 Output (Cylinder #7)
B25	Injector C Output
B26	Injector B Output

P2A

Pin	Function
A1	Input #6 (52THG)
A2	Input #10 (52THG)
A3	Input #14 (5G)
A4	Input #18 (FS)
A5	Input #21 (5HG)
A6	Input #25 (5HG)
A7	WB2 COMPR2
A8	WB2 Shield
A9	WB2 HTR -
A10	Input #5 (52THG)
A11	Input #9 (52HG)
A12	Input #13 (5G)
A13	Input #17 (FS)
A14	Input #20 (5HG)
A15	Input #24 (5HG)
A16	WB2 COMPR1
A17	WB2 VS-/IP+
A18	Sensor Ground
A19	Input #8 (52THG)
A20	Input #12 (5G)
A21	Input #16 (FS)
A22	Speed Inputs Ground
A23	Input #23 (5HG)
A24	Input #27 (5HG)
A25	WB2 VS+
A26	Sensor +5v
A27	Input #7 (52THG)
A28	Input #11 (52THG)
A29	Input #15 (5G)
A30	Input #19 (FS)
A31	Input #22 (5HG)
A32	Input #32 (5HG)
A33	WB2 IP+
A34	WB2 HTR +

P2B

Pin	Function
B1	Output #16 (H P+)
B2	Output #15 (H P+)
B3	Output #11 (G P-)
B4	Output #17 (H P+)
B5	Output #9 (G P-)
B6	Output #6 (G P-)
B7	Injector J Output
B8	Output #7 (G P-)
B9	Output #12 (G P-)
B10	Output #18 (H P+)
B11	Output #10 (G P-)
B12	Output #5 (G P-)
B13	Injector K Output
B14	EST Ground Output
B15	EST I Output
B16	EST K Output
B17	EST J Output
B18	EST L Output
B19	Injector L Output
B20	EST 12V Output
B21	Output #8 (G P-)
B22	Output #19 (H P+)
B23	Output #20 (H P+)
B24	Output #13 (H P+)
B25	Output #14 (H P+)
B26	Injector I Output

P3	
Pin	Function
B1	Sensor Ground
B2	Input #31 (5)
B3	Input #32 (5)
B4	DBW #2 A Out
B5	DBW #2 B Out
B6	DBW #1 A Output
B7	DBW #1 B Output
B8	Sensor +5v
B9	Input #30 (5)
B10	Output #24 (H P+)
B11	Output #23 (H P+)
B12	Output #22 (G P-)
B13	Output #21 (G P-)
B14	CAN2 Lo
B15	Input #29 (5)
B16	Sensor Ground
B17	Global Folder Config Select Switch
B18	Input #36 (52THG)
B19	Output #25 (H P+)
B20	CAN2 Hi
B21	Input #28 (5)
B22	Sensor +5v
B23	Input #33 (5)
B24	Input #35 (52THG)
B25	Input #34 (5)
B26	Output #26 (H P+)

P4	
Pin	Function
B1	Output #30 (G P-)
B2	Output #29 (G P-)
B3	Output #36 (H P+)
B4	Output #35 (H P+)
B5	Output #32 (H P+)
B6	Output #34 (H P+)
B7	Output #28 (G P-)
B8	Input #46 (5HG)
B9	Input #45 (5HG)
B10	Input #47 (5HG)
B11	Output #31 (H P+)
B12	Output #33 (H P+)
B13	Output #27 (G P-)
B14	Sensor Ground
B15	Input #42 (5HG)
B16	Input #48 (5HG)
B17	Input #37 (52THG)
B18	Input #39 (FS)
B19	Input #40 (FS)
B20	Sensor +5v
B21	Input #41 (5HG)
B22	Input #43 (5HG)
B23	Input #44 (5HG)
B24	Input #49 (F5G)
B25	Input #38 (52THG)
B26	Input #50 (F5G)

3.0 Main Harness

The following overviews all the connections on the “Main Harness”. The Main Harness is the primary harness that supports all the primary engine sensors, fuel and ignition for 8 cylinder engines, the #1 wideband oxygen sensor, and the first four programmable input and output channels. There are two connectors for this harness designated as “P1A” (pin designations below that start with an A) and “P1B” (pin designations below that start with a B).

The following descriptions indicate the name of the item and the name as labeled on the harness is shown in parenthesis. The pinout for the ECU is then shown. If the wires are terminated into the same connector on every type of main harness, the connector pinout is given as well. If the connector may vary by application, such as a TPS or IAC, the connector pinout is not given. To see the connector pinout for a specific application, locate the wiring diagram themselves contained in the WIRING APPENDIX, located at the end of this manual.

4.0 Primary Sensors

4.1 Throttle Position Sensor (TPS)

Holley EFI systems work with any 0-5V throttle position sensors.

- A5 – TPS Signal
- A18 – Sensor Ground
- A26 – Sensor +5V Reference Out

4.2 Manifold Air Pressure Sensor (MAP)

Holley EFI systems work with 1, 2, 3, 4, or 5 Bar MAP sensors. Make sure to select the proper sensor used in the software.

A18 – Sensor Ground
A23 – MAP Sensor Signal
A26 – Sensor +5v Reference Out

4.3 Coolant Temperature Sensor (CTS)

Holley EFI systems work with any 2 wire thermistor style coolant temperature sensors. Make sure to select the proper sensor in the software.

A18 – Sensor Ground
A19 – Coolant Temp In

4.4 Manifold Air Temperature Sensor (MAT)

Holley EFI systems work with any 2 wire thermistor style manifold air temperature sensors. Make sure to select the proper sensor in the software.

A11 – Manifold Air Temp In
A18 – Sensor Ground

4.5 Knock Sensor (Knock)

Holley EFI systems work with either a one wire or two wire knock sensor. Application specific harnesses will have the correct knock sensor connections installed on the harness. A Universal harness comes with a 3 pin metripak connector. If a knock sensor is added, it should be connected into this connector

A21 – Knock Sensor #2 Input (**Pin A**)
A29 – Knock Sensor #1 Input (**Pin B**)
A18 – Sensor Ground (**Pin C**)

4.6 Wide Band Oxygen Sensor (WB02)

Holley EFI systems can work with either a Bosch (PN 554-101) or NTK (PN 554-100) wide band oxygen sensor. These sensors must be purchased from Holley as they are calibrated specifically for use with Holley EFI systems.

A34 – WB1 HTR+ (**Pin A**)
A9 – WB1 HTR - (**Pin B**)
A16 – WB1 COMPR1 (**Pin C**)
A7 – WB1 CCOMPR2 (**Pin D**)
A17 – WB1 VS-/IP- (**Pin E**)
A33 – WB1 IP+ (**Pin F**)
A25 – WB1 VS+ (**Pin G**)
A8 – WB1 Shield (**Pin H**)

4.7 Fuel Pressure (Fuel)

A fuel pressure input is a standard feature on Holley EFI. A connector is installed that is plug-and-play with Holley 100 PSI pressure transducer PN 554-102. A different 0-5V transducer can be used, but the calibration must be set up as a custom sensor in the software. If these are not connected to a pressure transducer, the Fuel and Oil Pressure will read “LOW Err” in the data monitor. This will not cause any issues.

A18 – Sensor Ground (**Pin A**)
A26 – Sensor +5V Reference Out (**Pin B**)
A31 – Fuel Pressure Signal (**Pin C**)

4.8 Oil Pressure (Oil)

An oil pressure input is a standard feature on Holley EFI. A connector is installed that is plug-and-play with Holley 100 PSI pressure transducer PN 554-102. A different 0-5V transducer can be used, but the calibration must be set up as a custom sensor in the software. If these are not connected to a pressure transducer, the Fuel and Oil Pressure will read "LOW Err" in the data monitor. This will not cause any issues.

A18 – Sensor Ground (**Pin A**)

A26 – Sensor +5V Reference Out (**Pin B**)

A20 – Fuel Pressure Signal (**Pin C**)

4.9 CANbus (CAN)

All harnesses have a CANbus communications connector. This is used to communicate with CANbus devices, such as the Avenger Handheld tuning module or the 5.7" Touch Screen LCD. If these devices or any other CANbus device is not being used, there is no need to do anything with this connector.

A24 – CAN Lo (**Pin B**)

A32 – CAN Hi (**Pin A**)

5.0 Primary Outputs

5.1 Idle Air Control (IAC)

The terminated IAC connector is for a 4 wire stepper type IAC. A 2 wire PWM (Pulse Width Modulated) IAC can be used, see section 9.2. The following shows the outputs for a stepper IAC.

B1 – IAC A Lo

B2 – IAC A Hi

B8 – IAC B Lo

B9 – IAC B Hi

5.2 Fuel Injector Outputs (Injectors)

All terminated harnesses have a fuel injector connector. Various fuel injector harnesses plug into this connector. It is essential these harnesses are used so that injector firing sequence is maintained.

Note that for engines with different firing orders, you do NOT change these pins. The engine's firing order is input in the software itself. Pin's A-H are routed to the cylinder number designation for the engine (i.e. A goes to cylinder #1, B goes to cylinder #2, etc). V8 harnesses offered by Holley are labeled for GM, Ford, and Chrysler engines.

B19 – Injector A (**Pin A**)

B26 – Injector B (**Pin B**)

B25 – Injector C (**Pin C**)

B13 – Injector D (**Pin D**)

B7 – Injector E (**Pin E**)

B4 – Injector F (**Pin F**)

B5 – Injector G (**Pin G**)

B6 – Injector H (**Pin H**)

+12V Power – (**Pins J/K**)

5.3 Ignition Adapter (Ignition)

The Ignition Adapter connector contains all the wires needed to connect to adapter harnesses offered by Holley for various ignition systems and crank and cam sensor. The only ignition related wiring that is NOT contained on this connector is individual coil driver outputs for DIS applications.

The adapter is pinned as follows:

- A30 – Crank signal Input – Both digital and inductive (proper type must be selected in the software) **(Pin A)**
- A22 – Cam signal Input / Ignition Bypass Output– Both digital and inductive (proper type must be selected in the software) **NOTE:** If using a computer-controlled GM HEI Distributor, this pin will serve as the ignition bypass output **(Pin B)**
- A14 – IPU Ground **(Pin C)**
- Chassis Ground – **(Pin D)**
- A10 – Switched +12v **(Pin E)**
- A27 – NOT USED **(Pin F)**
- A14 – IPU Ground **(Pin G)**
- A28 – EST/Spout Output **(Pin H)**
- A14 – Shield Ground **(Pin J)**
- A14 - Shield Ground **(Pin K)**

NOTE: The crank and cam input wiring in both the main harness and adapter harnesses use a shielded/grounded cable. The shield is grounded at the ECU end. You do not ground both end of shielded/grounded cable. It is always recommended to use shield/grounded cable to protect the integrity of the crank or cam sensor input signals. This is especially important when using a magnetic pickup. A hall effect sensor is much less susceptible to noise interference and is always the recommended sensor type to use.

Holley offers the following ignition adapter harnesses.

271R1012A – “Tach Out” – This adapter connects into the “Tach Out” on a CD ignition box when the ECU is NOT controlling ignition timing. This adapter is included with all HP and Avenger TBI and Multiport Fuel Injection systems.

558-303 – Magnetic Pickup Harness – Intended for magnetic pickups. Either crank trigger or distributor mounted - Does not contain cam sync wiring.

558-304 – HEI – Connects to a small cap GM HEI computer controlled distributor

558-305 – Ford TFI – Connects to a Ford TFI Distributor.

558-306 – Universal Unterminated Ignition Harness – Contains ignition adapter connector and all wiring to connect to any crank and cam sensors (pins A-K). Also, contains shielded/grounded cable for crank and cam sensor inputs. The user must supply terminals and connectors to plug into their chosen sensors.

NOTE: See section 8.0 for diagrams on wiring most ignition systems.

6.0 Loose Wires

The following loose wires in the main wiring harness should be connected as follows on all systems:

12V Switched – Color = Red/White – Should be connected to a clean +12 volt power source. Power source should only be active when the ignition is on. Make sure source has power when engine is cranking as well. Not all sources apply power when the ignition switch is in “cranking” position.

12V Battery – Color = Red – Should be connected directly to the battery. There is a fuse holder attached that should contain a 20A rated fuse. This powers the fuel pump and fuel injectors.

12V Fuel Pump – Color = Green - Used to directly power a fuel pump (+12 volt). Fully terminated harnesses utilize a relay to supply this power. 14 gauge wire is used. Due to this, it is not recommended for pumps that draw over 10-12 Amps to use this wire. For high current pumps, use this wire to trigger a separate relay and use larger gauge wire to feed the pump - 10 gauge is recommended.

Points Output – Color = White – Used to trigger a CD ignition box. See the ignition wiring section for detailed wiring.

Ignition/DIS Chassis Ground – Color = Black – Connect to a ground point that has excellent connectivity with both the engine and the battery.

“Coil – ” – Color = Yellow – Used for an RPM input signal when not controlling timing and NOT running a Capacitive Discharge (MSD) ignition system. See the ignition wiring section 8.0 for detailed wiring. **WARNING!** Connecting this wire to the coil of a CD ignition will damage the ECU.

7.0 Main Power

7.1 Overview

Holley HP and Dominator ECU's use the same main power cable. These wires should be run directly to the battery. 10 gauge wire is used. The harness comes with a 40 Amp fuse pre-installed. Do not substitute smaller gauge wires.

8.0 Ignition System Wiring

Both the HP and Dominator Systems support a wide variety of ignition systems. The following schematics show how to wire the most typical systems

8.1 LSx Engines with 24x Crankshaft Reluctor Wheel

These engines include LS1, LS6, a few early LS2 engines and some truck engines. Harness P/N 558-102 is "plug and play" for the Camaro/Corvette applications that have 24x crankshaft reluctor wheels and 1x camshaft trigger wheels. The harness is designed with the camshaft sensor located at the back of the engine. The early 24x LS2 engines may have it mounted in the front, in which case the cam sensor wire will have to be extended. The harness plugs into the factory GM coils harnesses. No additional harnesses are needed other than an injector harness to run the engine (unless drive by wire or transmission control is desired). For standard Bosch style injector connectors, PN 558-200 can be used. For EV6 style injectors, use injector harness PN 558-201.

NOTE: On GM LSx engines, always install the black "ignition ground" wire in the harness to the engine block or cylinder head.

8.2 LSx Engines with 58x Crankshaft Reluctor Wheel

These include most LS2, LS7, LS3, and some truck engines. Harness P/N 558-103 is "plug and play" for most 58x crankshaft reluctor wheels and 4x camshaft trigger wheels. The harness plugs into the factory GM coils harnesses. No additional harnesses are needed other than an injector harness to run the engine (unless drive by wire or transmission control is desired). For standard Bosch style injector connectors, PN 558-200 can be used. For EV6 style injectors, use injector harness PN 558-201.

NOTE: On GM LSx engines, always install the black "ignition ground" wire in the harness to the engine block or cylinder head.

8.3 Small Cap Computer Controlled GM HEI

To connect to a small cap computer controlled GM HEI, ignition adapter harness PN 558-304 is required. The following diagrams overview how to wire with and without a CD ignition box.

HOLLEY EFI TO GM HEI IGNITION - USING COMPUTER CONTROLLED DISTRIBUTOR, EXTERNAL COIL (ECU CONTROLLING TIMING)

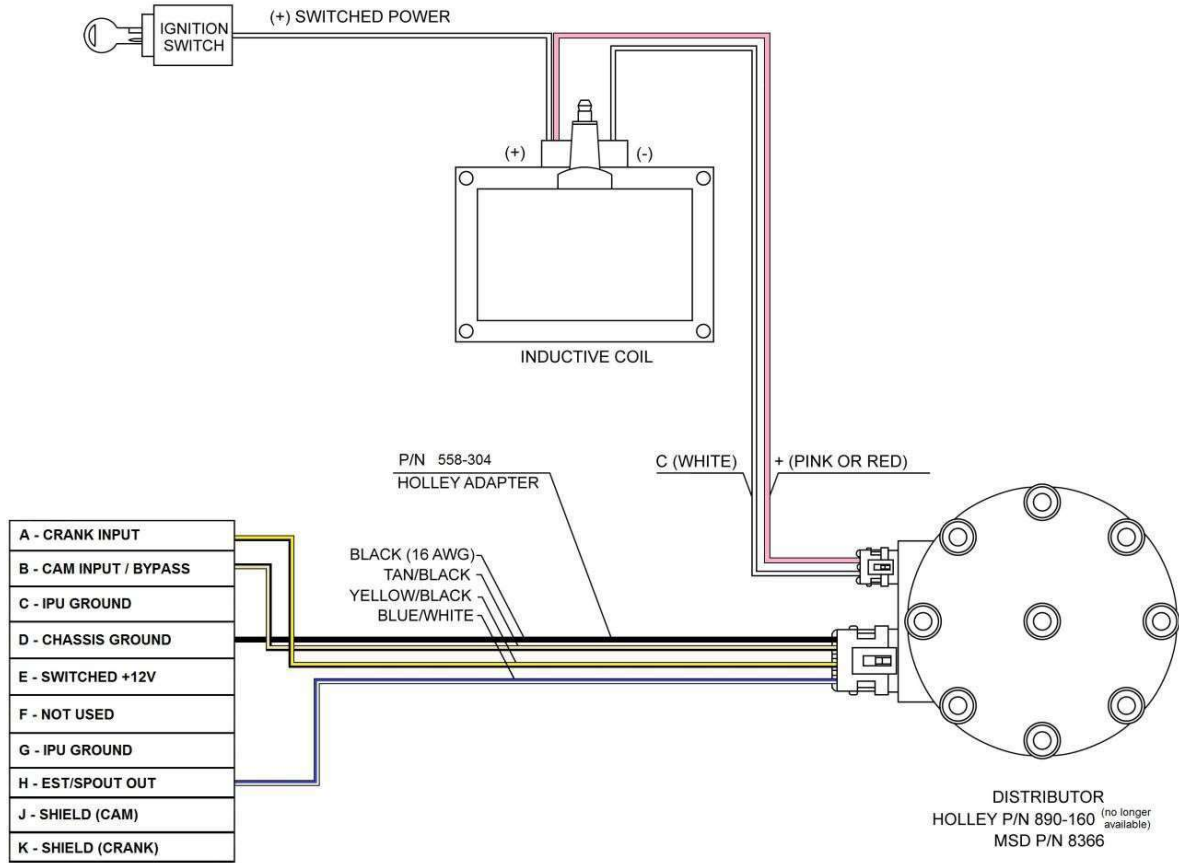

Figure 3

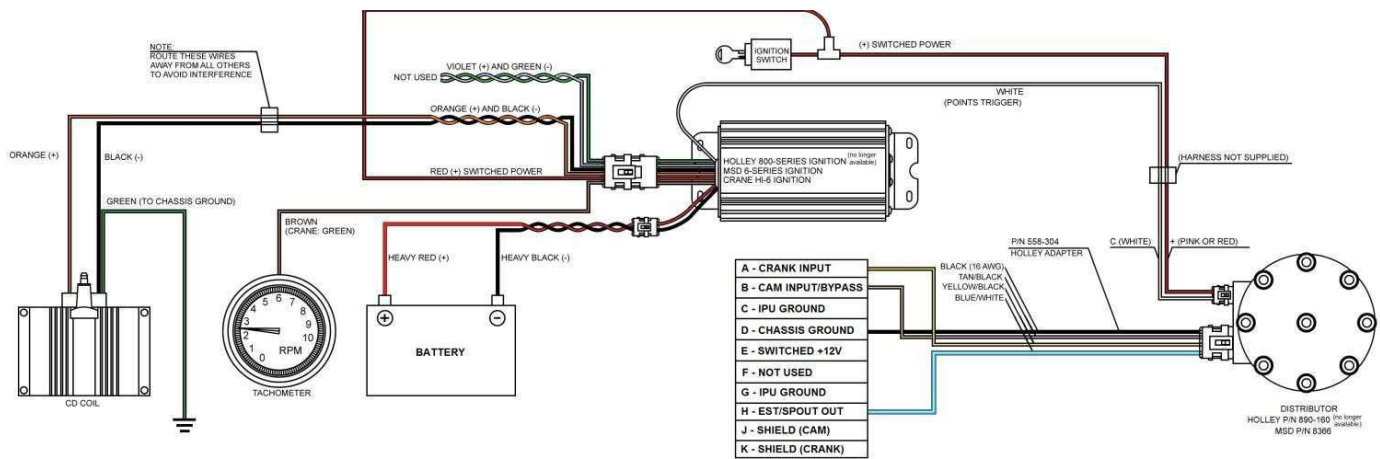

Figure 4

8.4 Ford TFI

To connect to a Ford TFI ignition module, ignition adapter harness PN 558-305 is required. Note that the system is designed only for distributors used for sequentially injected Ford engines such as 5.0L Mustangs. A very small amount of TFI style distributors around 1985 did not have a cam sync ident in the pickup. The following diagrams overviews how to wire a TFI distributor with and without a CD ignition box.

HOLLEY EFI TO FORD TFI IGNITION (SEQUENTIAL) - USING FORD COMPUTER-CONTROLLED DISTRIBUTOR, TFI MODULE (ECU CONTROLLING IGNITION TIMING)

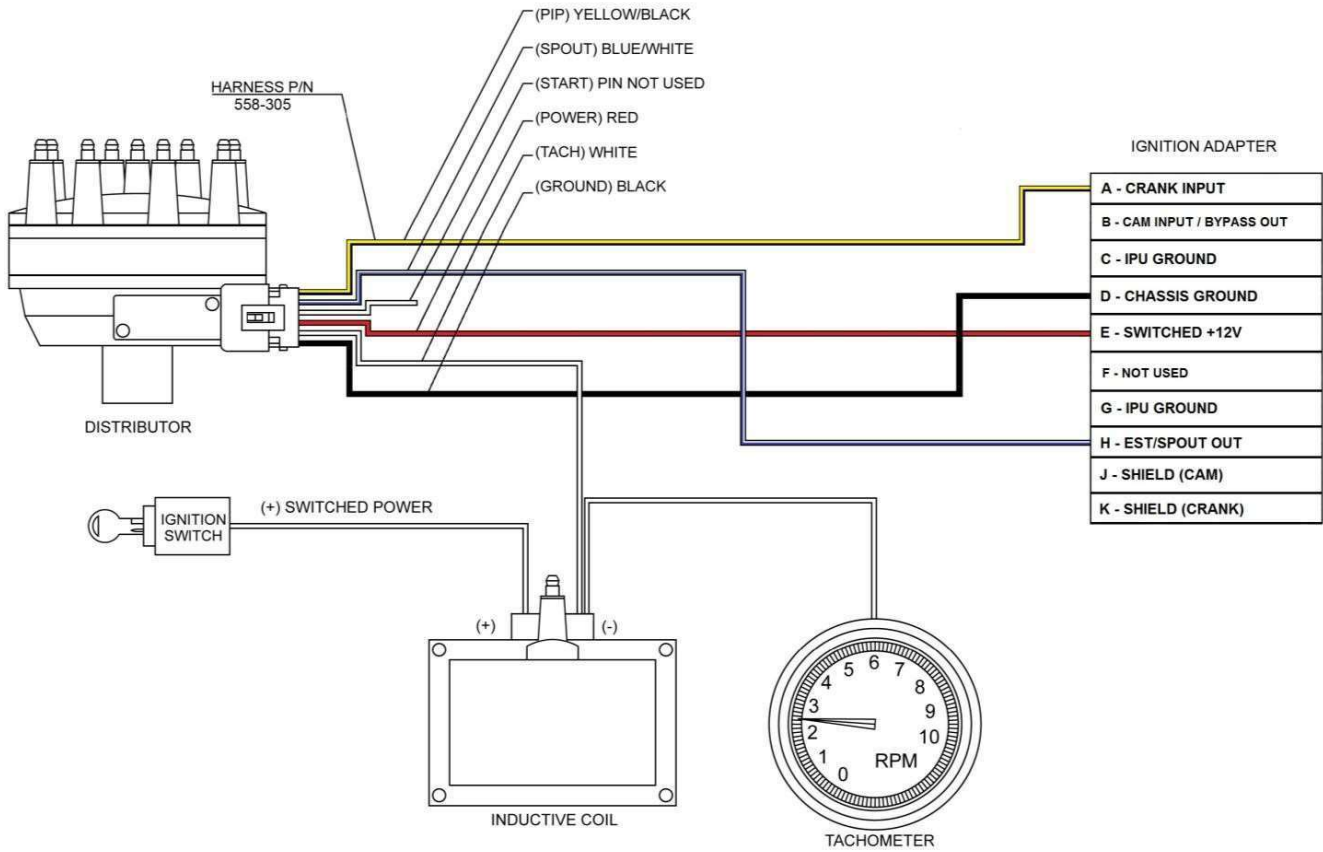

Figure 5

HOLLEY EFI TO AFTERMARKET IGNITION - USING FORD COMPUTER-CONTROLLED TFI DISTRIBUTOR (SEQUENTIAL), TFI MODULE (ECU CONTROLLING IGNITION TIMING)

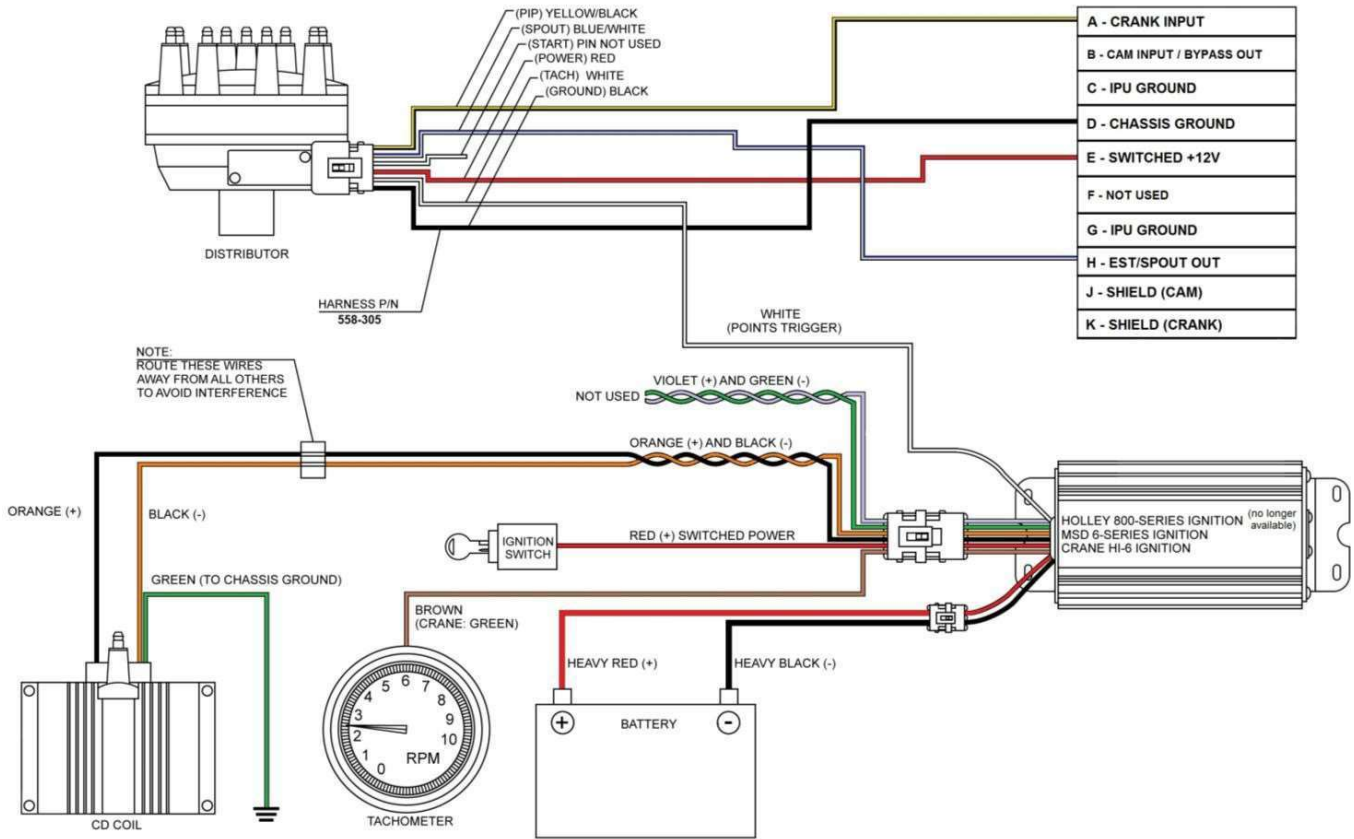

Figure 6

8.5 NON- ECU Controlled Timing Applications (ex. GM Non-ECU Controlled Large Cap HEI)

To connect to a distributor that has mechanical advance and is not controlled by the ECU (ex. GM large cap HEI non-computer controlled distributor), refer to the following diagrams.

- If **NOT** using a CD ignition box, connect the loose YELLOW (NOT yellow/black wire) in the harness to the negative side of the ignition coil.
- If using a CD ignition box, connect the purple crank input wire located in the ignition adapter harness to the "tach out" in the ignition box. This wire is located in Pin A of the 10 pin ignition adapter in the EFI harness (Do **NOT** use the purple wire in pin B – this is for the camshaft sensor input). The following shows three options in order of preference:
 - 1) Most kits come with a 10 pin ignition adapter harness with a single YELLOW/BLACK wire that directly connects to the ignition adapter on the main harness. If you have this adapter, use it to connect the YELLOW/BLACK wire into the tach output of the CD ignition box.
 - 2) If your kit contains an HEI distributor ignition adapter harness (4 wires), you can cut and splice into the YELLOW/BLACK wire in it. This saves you from having to modify the main harness.
 - 3) If you have no ignition adapter harness, you can splice into the purple wire in the main harness.

If any splicing is done, make 100% certain that this is a very solid connection. Solder and heat shrink is highly recommended. This supplies the engine speed signal to the ECU and if the connection is not solid, the engine will not run properly.

HOLLEY EFI TO GM HEI - USING MECHANICAL AND VACUUM ADVANCE 4-PIN MODULE DISTRIBUTOR (ECU "NOT" CONTROLLING IGNITION TIMING)

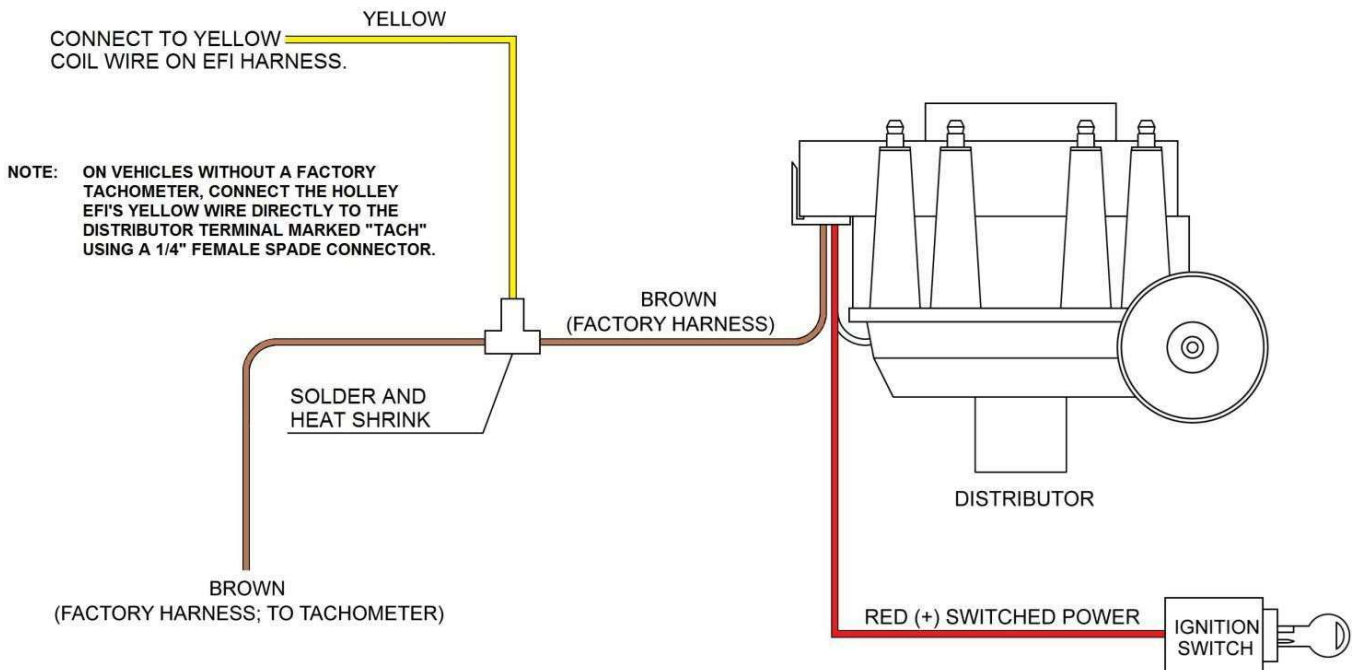

Figure 7

**HOLLEY EFI TO AFTERMARKET IGNITION - USING MAGNETIC PICK-UP DISTRIBUTOR
(ECU "NOT" CONTROLLING IGNITION TIMING)**

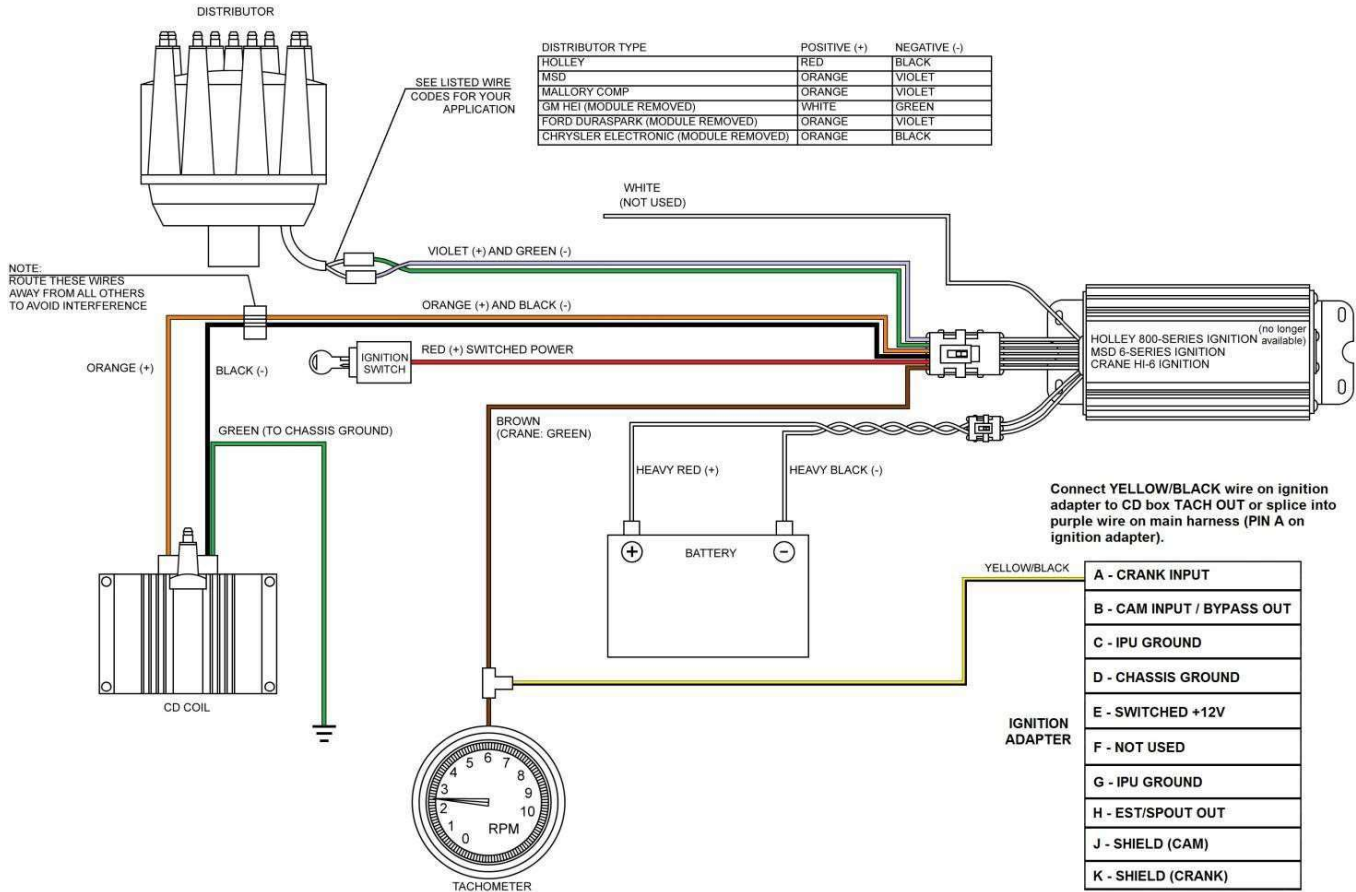

Figure 8

8.6 Magnetic Crank Pickup

The follow diagrams are for running a magnetic pickup, either a crank trigger or a distributor. To run just a magnetic pickup crank input and no camshaft input, PN 558-303 should be purchased. If a cam sync input will be used as well, it is recommended to use PN 558-306 which will contain wiring for both the crank and cam sensor inputs. It is critical that properly installed shielded and grounded cable is used when using a magnetic pickup, or it is likely that EMI will disturb the crankshaft signal. Both PN 558-303 and 558-306 come with the proper cabling. It must be installed properly as well. Make sure that the shield is properly grounded which requires it being grounded at the ECU with that ground maintained through the ignition adapter connection.

Note: The user must supply the proper terminals/connectors for the crank and cam sensors they are using.

HOLLEY EFI TO AFTERMARKET IGNITION - USING MAGNETIC PICK-UP CRANK TRIGGER (ECU CONTROLLING IGNITION TIMING)

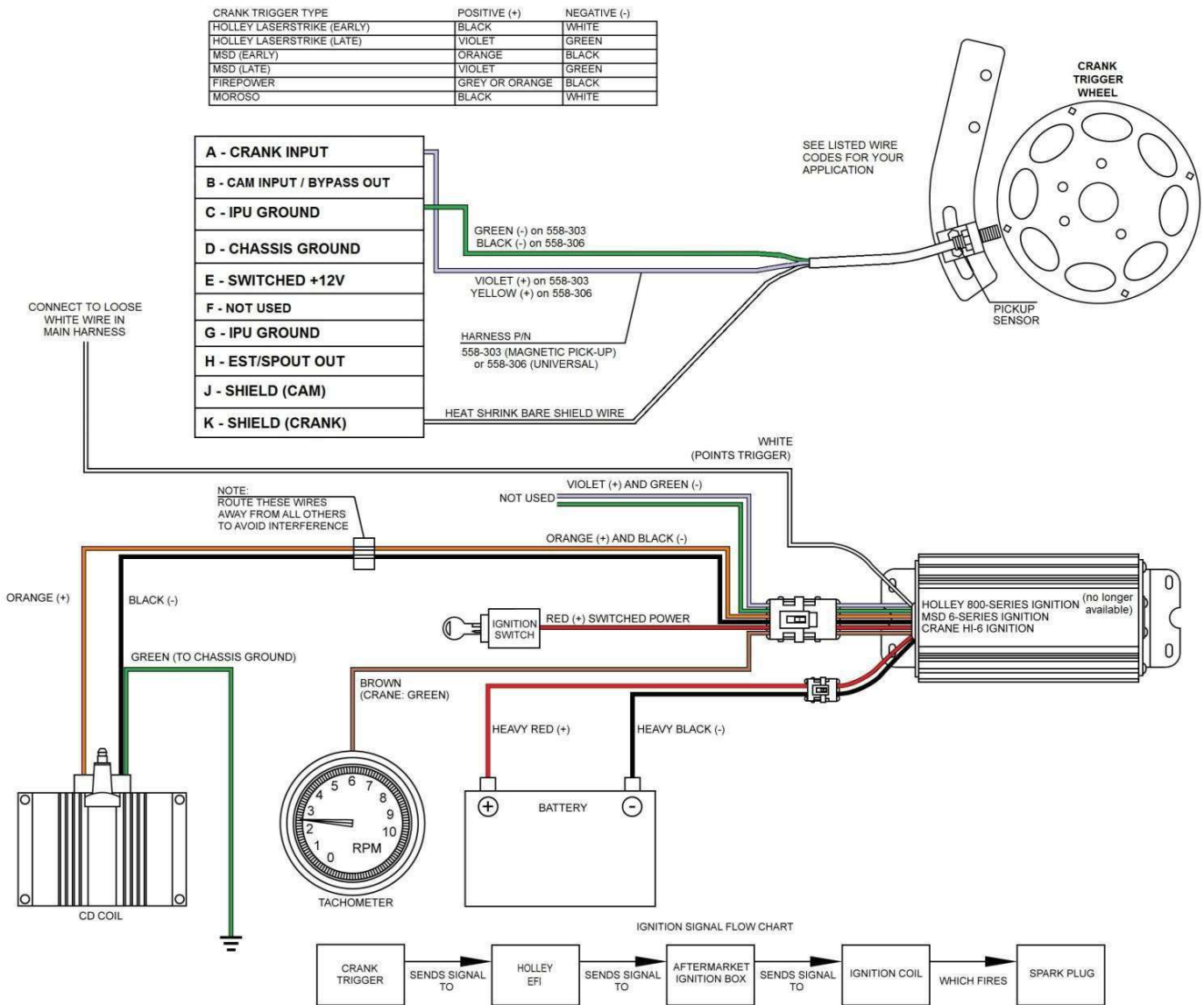

Figure 9

8.7 Magnetic Cam Pickup

The following diagram is to wire a magnetic cam sync signal. It utilizes the shielded/grounded cabling found in PN 558-306. It is critical that properly installed shielded and grounded cable is used when using a magnetic pickup, or it is likely that EMI will disturb the camshaft signal.

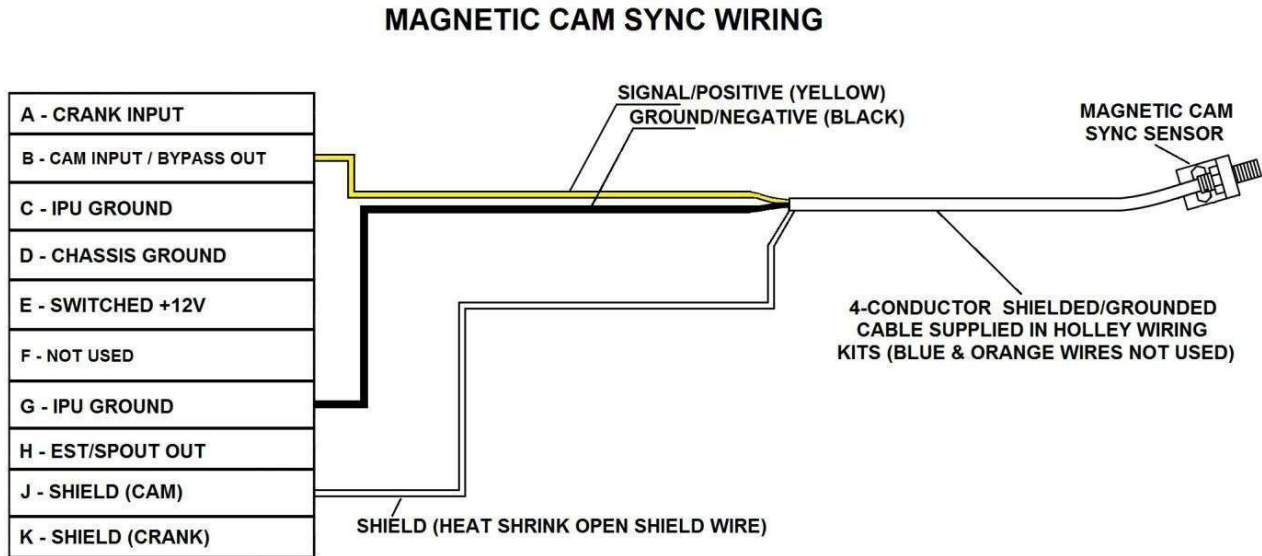

Figure 10

8.8 Hall Effect Crank Pickup

The following diagrams are for running a hall effect pickup, either a crank trigger or a distributor. It is recommended to use PN 558-306 which will contain wiring for both the crank and cam sensor inputs. It is important that properly installed shielded and grounded cable is used when using a hall effect input. PN 558-306 comes with the proper cabling. It must be installed properly as well. Make sure that the shield is properly grounded which requires it being grounded at the ECU with that ground maintained through the ignition adapter connection.

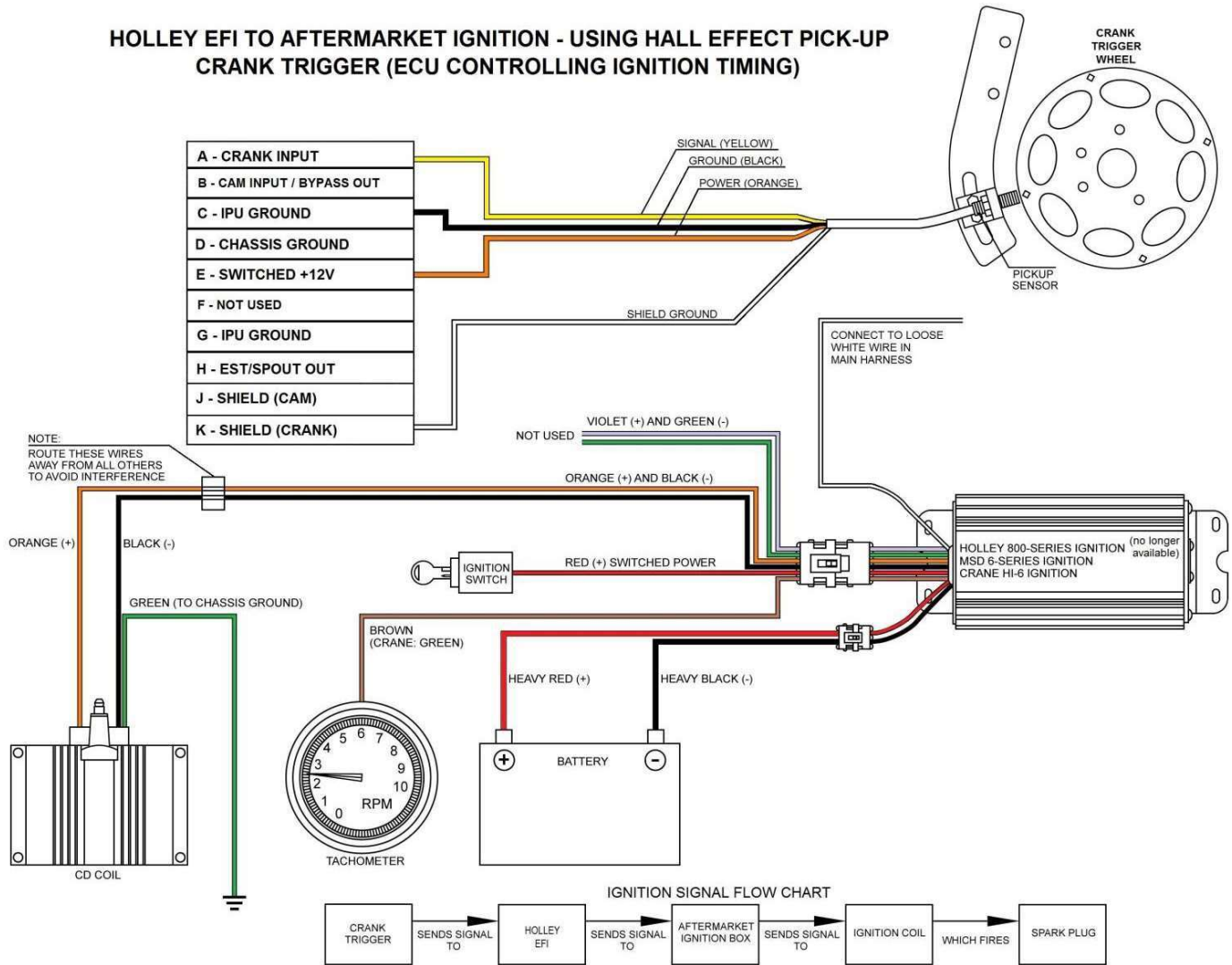

Figure 11

8.9 Hall Effect Cam Pickup

The following diagram is to wire a hall effect cam sync signal. It utilizes the shielded/grounded cabling found in PN 558-306. It is desirable to use a properly installed shielded and grounded cable so that EMI will not disturb the camshaft signal.

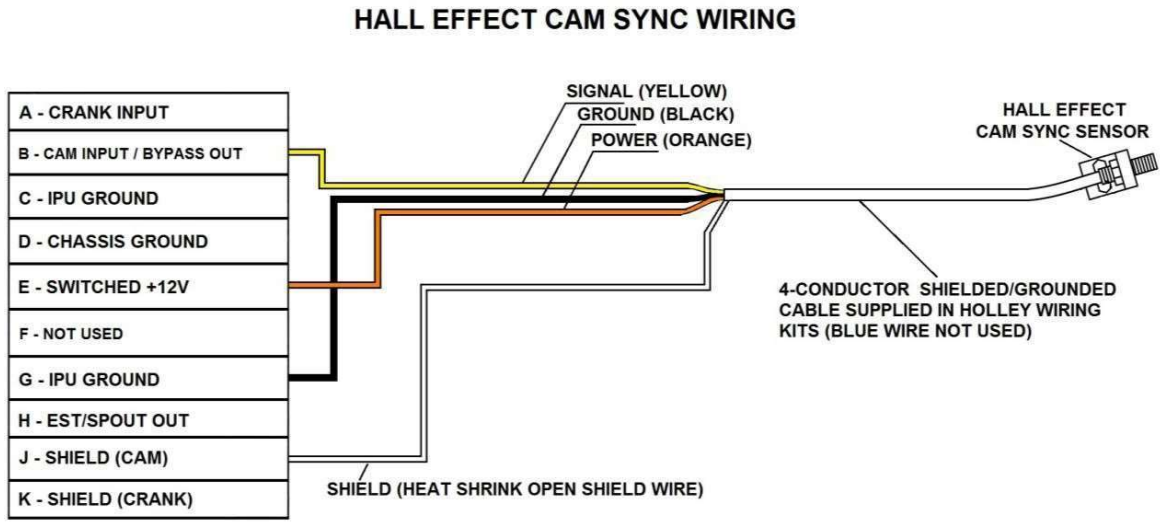

Figure 12

8.10 Holley Distributorless Ignition System (DIS)

Holley DIS can be retrofitted onto any engine. It is a waste-spark type system which means that one twin-tower coil feeds two cylinders that fire 360 degrees apart. These coils provide a high level of spark energy to feed high powered nitrous and forced induction engines. A cam sync is not required when using a Holley 60-2 crank pickup wheel, although one is required for sequential fuel control and individual cylinder fuel and spark timing.

NOTE: Use of Individual Cylinder Timing when using Holley DIS: At the present time, the Individual Cylinder Timing function, when used with waste fire ignition systems, such as the Holley DIS, does not have full individual tuning capabilities. A timing retard is “shared” between both cylinders attached to a coil. For example, if cylinders 1 and 6 are attached to a coil, and a timing retard of 2 degrees is commanded for cylinder #1, cylinder #6 will have a 2 degree retard as well. The retard value for the cylinder with the most amount of retard requested, will be used for both.

The figures below show how to wire the coils for 4, 6, and 8 cylinder applications. An example is given for standard firing order Small and Big Block Chevy engines, as well.

Holley PN’s 556-100, 101, and 105 come with the following wiring harnesses:

- **Main Power Cable** – The main power is a fused 14 ga cable that should go directly to battery power. It then splices into the individual coil harnesses.
- **Cam/Crank Sensor Harness** – The cam/crank sensor harness is a fully terminated ignition adapter that connects directly to the Holley crank sensor supplied in the kit. It also includes a terminated cam sync connector. This connector plugs into the GM sync pulse distributor used on certain 1990’s big block vehicles, AC Delco PN 213-350. This distributor was reproduced and is sold by EFI Connection (www.eficonnection.com) for a very reasonable price. This distributor, which can be used on Small or Big Block Chevy standard deck height engines, serves the purpose as an oil pump drive and cam sync signal. It is very low profile.
- **Coil A, B, C, D Harnesses** – There are 4 harness “pigtaills” for each coil. Each has a different wire color for each individual coil trigger. The rest of the wires are tied together as shown in the diagram. The following overviews each coil pin:
 - A – Chassis ground. Tie these together. If connecting all together into another wire, make sure this wire is at least a 14 gauge wire.
 - B – Trigger Ground. These wires need to be connected and run back to the ECU to pin B14. They can be tied together near the coils or back at the ECU. It is a low current line.
 - C – Coil Trigger. This is the individual trigger from the ECU to each coil. Wire per the “ECU to Coil Wiring” instructions below.
 - D – 12v Battery. Constant 12v power supplied from the battery. Tie together and use the supplied fused, 14ga wire to run to battery power.

NOTE: Keep this wiring separated from the spark plug ignition wires. Do not run these wires through or in parallel with the spark plug wires.

Coil and Plug Wiring

It is imperative that the wiring of the coils and spark plug wiring is done correctly. If it is not, a cylinder will fire at the incorrect time and it likely that the starter, flex plate, and possibly other components will be damaged!

ECU to Coil Wiring

Use Figures 13 through 16 below as a worksheet to fill out the proper wiring for the coils and ECU. Perform the following steps on this worksheet:

- 1) Enter the engine firing order as indicated in the yellow boxes at the top. This will be used as a "cross reference" chart.
- 2) In all the yellow boxes through the diagram, enter the corresponding engine cylinder for each letter based on the cross reference chart.
- 3) Using the "ECU Pinout" diagram, enter the proper ECU pin in the orange boxes based on the cylinder number entered for each.
- 4) You can now wire based on this chart. Insert the ECU coil trigger pins into the proper locations on the P1B ECU Connector.

CAUTION: If the coils are not wired in the correct sequence, if spark plugs are not routed to the correct coils, OR if the firing order is not entered into the software correctly, the wrong cylinder WILL be fired. This will likely damage the starter, flex plate or worse. Before starting an engine, it is highly advised to disconnect the fuel injectors and put a timing light on each plug wire to ensure it is firing at the correct crank angle. Double-check your wiring!

HOLLEY DISTRIBUTORLESS IGNITION WIRING - 8 CYLINDER

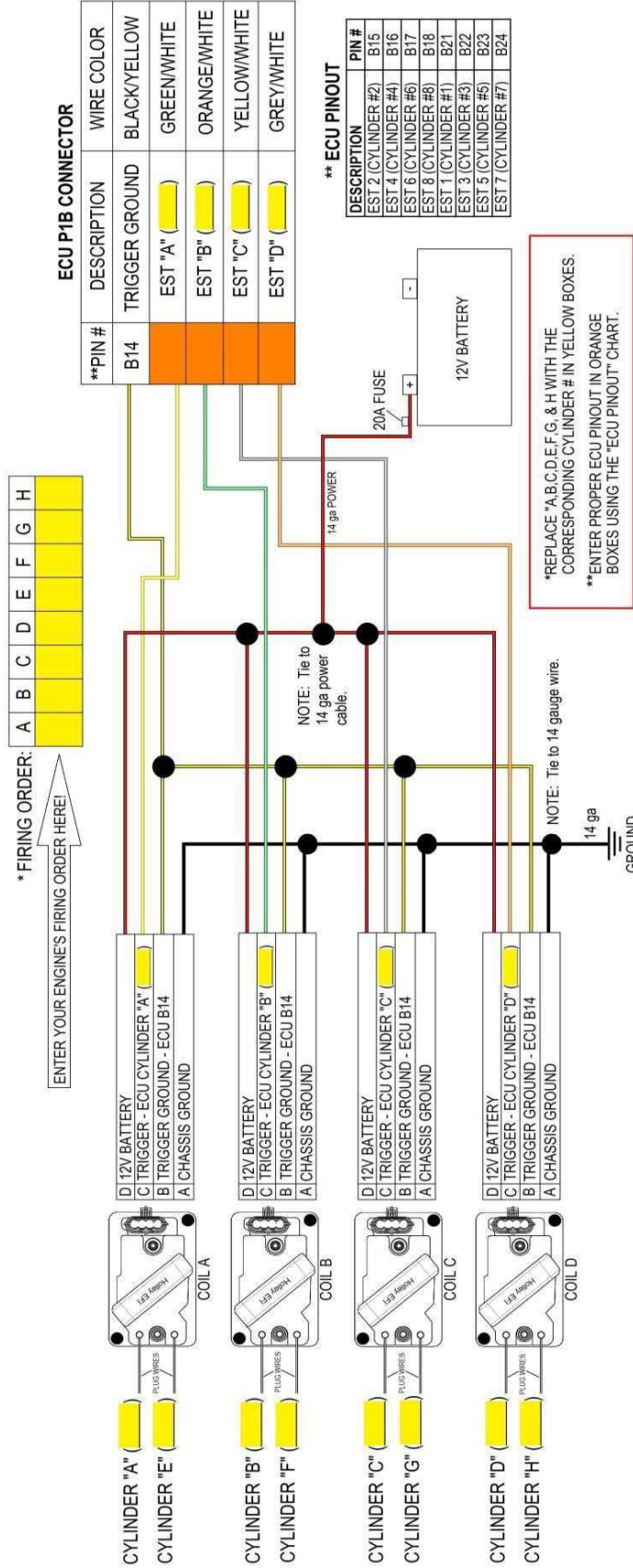

Figure 13

HOLLEY DISTRIBUTORLESS IGNITION WIRING - 8 CYLINDER

EXAMPLE: SMALL/BIG BLOCK CHEVY WITH STANDARD FIRING ORDER

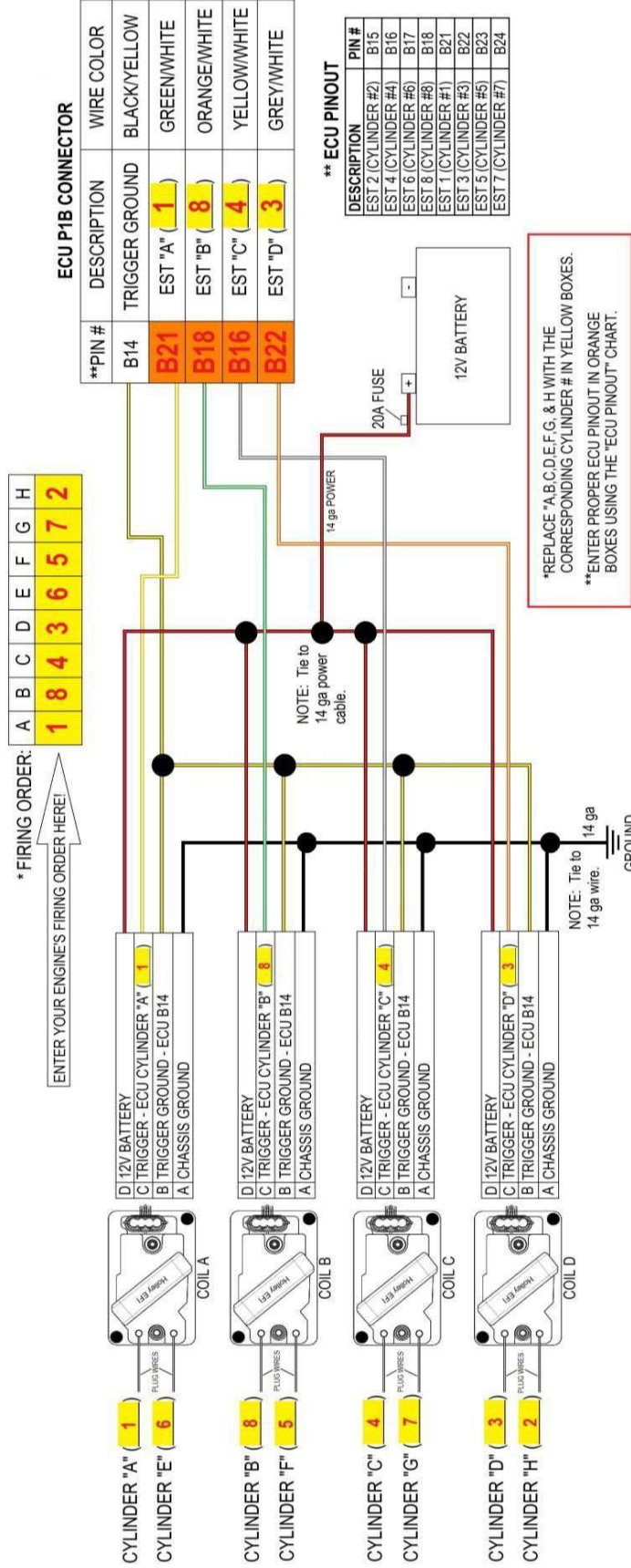

Figure 14

HOLLEY DISTRIBUTORLESS IGNITION WIRING - 6 CYLINDER

* FIRING ORDER:

A	B	C	D	E	F
---	---	---	---	---	---

[ENTER YOUR ENGINE'S FIRING ORDER HERE!]

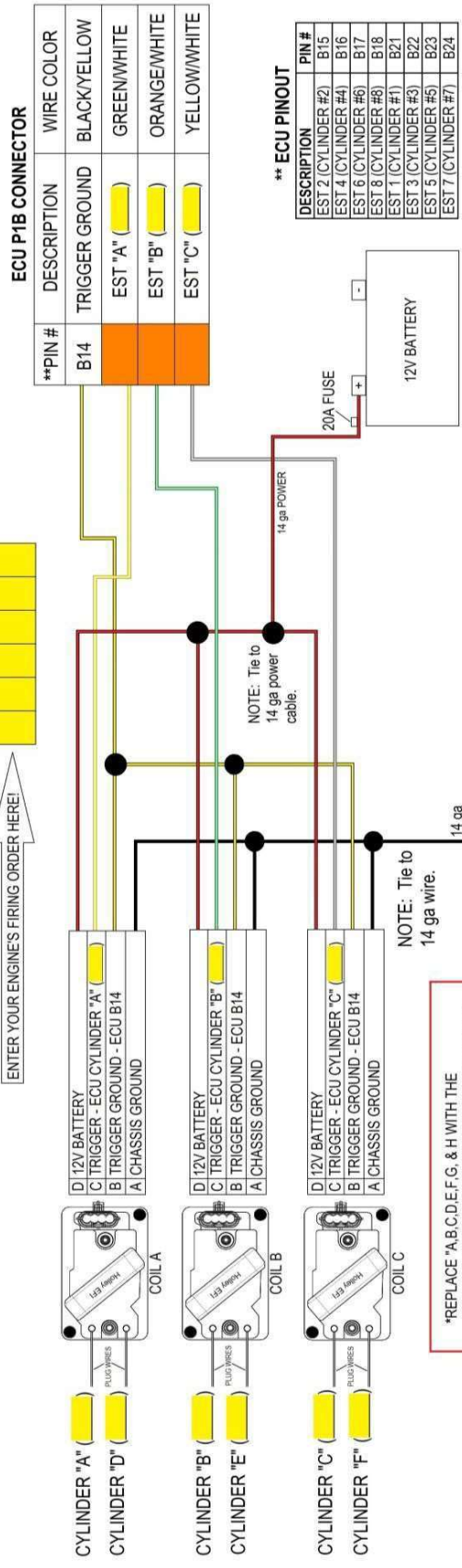

*REPLACE "A,B,C,D,E,F,G & H" WITH THE CORRESPONDING CYLINDER # IN YELLOW BOXES.
 **ENTER PROPER ECU PINOUT IN ORANGE BOXES USING THE "ECU PINOUT" CHART.

Figure 15

HOLLEY DISTRIBUTORLESS IGNITION WIRING - 4 CYLINDER

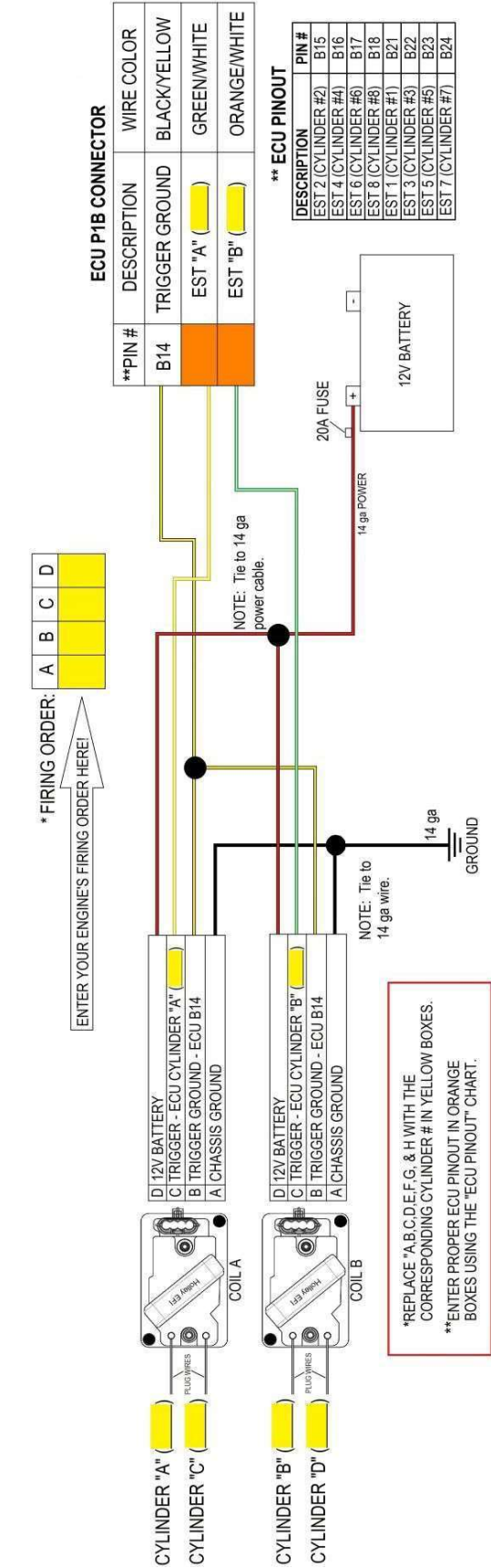

Figure 16

9.0 Programmable Inputs and Outputs

Programmable input and outputs are intended to be any input or output that is created by the user when a Global Folder is configured. Once configured, they must be assigned to a specific pin location on the Pin Map, and then physically wired per the assigned location.

NOTE 1: As a standard wiring practice, DO NOT wire any input or output to a source that draws more than 2 amps. This is especially true when connecting to something with a “coil”, such as any type of solenoid. If the device exceeds 2 amps, you should connect the input or output to the trigger side of the relay used to power the device, not directly to the device. Note that this 2 amp limit pertains to inputs as well (not just outputs). When de-powered, some solenoids create a large fly-back voltage that is fed directly back into an input trigger of the ECU, if that input is directly connected to the solenoid.

9.1 Inputs

There are **seven** types of inputs that can be configured. The following lists them and reviews wiring recommendations. The designation on the Pin Map (Inputs) is given first, then a description.

1. **“H”** – Switched 12v or “High Side” input – This input will be triggered when system voltage is applied. Minimum triggering voltage is 4.5v. Do not exceed 24v.

Wiring: Connect up to any voltage source that is desired to trigger this input. See **NOTE 1** above.

2. **“G”** – Switched Ground or “Low Side” input – This input will be triggered when a ground is applied.

Wiring: Connect up to any ground source that is desired to trigger this input. See **NOTE 1** above.

3. **“5”** – 0-5 volt sensor input – Any 0-5 volt sensor input such as a TPS, MAP sensor, pressure transducer, and many others.

Wiring: Wire the signal wire from the 0-5v sensor used into the appropriate pin. Any 0-5v sensor requires a +5v reference voltage and a sensor ground. Each HEFI connector that has 0-5v inputs has its own +5v reference voltage output and sensor ground. These need to be properly wired to each 0-5v sensor used. The following outlines the sensor +5v reference voltage and sensor ground pins:

<u>Connector</u>	<u>Sensor +5v Reference Voltage Pin</u>	<u>Sensor Ground Pin</u>
P1A	A26	A18
P2A	A26	A18
P3	B8 and B22	B1 and B16
P4	B20	B14

It is acceptable to have multiple sensors share the same +5v and ground reference lines. Be sure to solder, heat shrink, etc. wires properly as poor connections will cause for inaccurate or faulty sensor readings.

Do not use +5v reference or ground sources from other controllers or power supplies to support the sensor, or sensor accuracy may be compromised.

4. **“2”** – 0-20 volt sensor input – Any 0-20 volt sensor input

Wiring: Connect to desired voltage input.

5. **“T”** – Thermistor temperature input – Most coolant and air temperature sensors are a 2 wire “thermistor” design.

Wiring: Connect to one side of the thermistor device. Connect the other side of the thermistor device to a “Sensor Ground” input pin to the ECU (same pins for a 0-5v sensor). These pins are as follows:

<u>Connector</u>	<u>Sensor Ground Pin</u>
P1A	A18
P2A	A18
P3	B1 and B16
P4	B14

6. **“F”** – Frequency or a Digital Speed Input – Designed for a digital voltage input from a speed/rotation sensor. A hall effect sensor is the common sensor used. Voltage range can be 4.5 to 24 volts.

Wiring: A hall effect sensor has 3 wires: Power, Ground, and Signal. Most sensors can be supplied with battery voltage (12v), a few require a 5 volt reference. Check with the specifications of your specific sensor. Although not usually needed with a hall effect sensor, it is always advised to use a shielded/grounded cable to wire them (all three wires can be shielded). The following is advised when wiring a hall effect sensor.

Signal – Run the sensor signal wire into the Pin Mapped channel

Power – Either supply with clean switched power, or if it is not used for another purpose, you can power from Pin P1B-B20 which is a clean 12v power source. If the sensor requires 5 volts, use a +5v reference line.

Ground – It is best to connect to an IPU (Inductive/Magnetic Pickup) or Sensor Ground. The following pins are IPU grounds:

<u>Connector</u>	<u>Sensor Ground Pin</u>
P1A	A14
P2A	A22

Shield Wire – If using shielded/grounded cable, connect the shield ground wire to the ECU only. It is best to connect it to an IPU ground.

7. **“S”** – Inductive Speed Input – Designed for an A/C voltage input from a speed/rotation sensor. A magnetic sensor is the common sensor used. The minimum arming voltage is 50 mV.

Wiring: It is highly advised to always use a shielded/grounded cable for any inductive signal. They are very susceptible to noise. An inductive sensor has two wires - a “positive” and “negative”. Connect the positive lead to the “S” input pin that was Pin Mapped. Connect the negative side to an IPU ground. These are as follow:

<u>Connector</u>	<u>Sensor Ground Pin</u>
P1A	A14
P2A	A22

9.2 Outputs

All PWM (Pulse Width Modulated) and switched outputs are rated at a maximum of 2A. If a device will draw more than 2A, some type or relay must be used. If the output is PWM, do not use a “switching” relay, but rather a solid state type relay designed to be pulse width modulated.

There are four types of outputs that can be configured. The following lists them and reviews wiring recommendations. The designation on the Pin Map (Outputs) is given first, then a description.

1. **“H”** – Switched 12v or “High Side” output – will output system voltage level.

Wiring: Connect the pin to the device to be triggered. See **NOTE 1** above.

2. **“G”** – Ground or “Low Side” output – will output a ground trigger.

Wiring: Connect the pin to the device to be triggered. See **NOTE 1** above.

3. **“P+”** - 12v Pulse Width Modulated output – Outputs a high side pulse width modulated output to control items such as a progressive nitrous solenoid or a PWM IAC – will output system voltage level. See **NOTE 1** above.

Wiring: Connect the pin to the device to be triggered. A PWM device has 2 wires, connector the other side of the device to ground.

4. **“P-”** – Ground Pulse Width Modulated output – Outputs a low side pulse width modulated output to control items such as a progressive nitrous solenoid or a PWM IAC. See **NOTE 1** above.

Wiring: Connect the pin to the device to be triggered. A PWM device has 2 wires, connector the other side of the device to a voltage source.

10.0 Nitrous System Wiring

The following reviews how to properly wire a nitrous oxide system being controlled by a HP or Dominator ECU.

Required Wiring

An enable/arming input is required. It can be a ground or +12v input (make sure to configure in the software). The primary activation is the TPS and Engine Speed, both of which are existing inputs.

GPO's

General Purpose Outputs (GPO's), which are optional, can be configured in the software. They are a +12v or ground output that can be used to trigger another device (ignition box timing retard, etc).

Input #1, #2, #3 – Three additional inputs can be wired in order to activate or deactivate nitrous. They work in conjunction with the TPS

and Engine Speed activation settings. These three inputs are optional. An example would be to enable one off the trans-brake such that nitrous is NOT activated when the trans-brake is applied. They can be configured as a ground or +12v input in the software.

Non-Progressive Wiring – Any non-progressive stage of nitrous can be wired with a conventional switching relay. The ECU will trigger the relay to activate the stage.

Progressive Wiring – When using progressive control, PN 554-111 must be used as a high current solenoid driver that the ECU controls. **A regular switching relay should never be used for progressive nitrous operation (other than for supplying constant power, it should never be “pulsed”).** Figure 17 shows the proper wiring for a single stage. For additional stages, additional driver modules are required. **Note:** PN 554-111 CAN be used for non-progressive stage, if desired, in lieu of a standard relay.

554-111 Software Configuration – The 554-111 solenoid driver trigger (pin 2) **MUST** be configured as a “PWM -” output in the software (the driver is ground triggered). Do not set it up as any other type or damage or unintended solenoid activation may result.

NOTE: NEVER have the ECU directly power a nitrous oxide solenoid. All nitrous solenoids require more than the 2A rating for the ECU outputs.

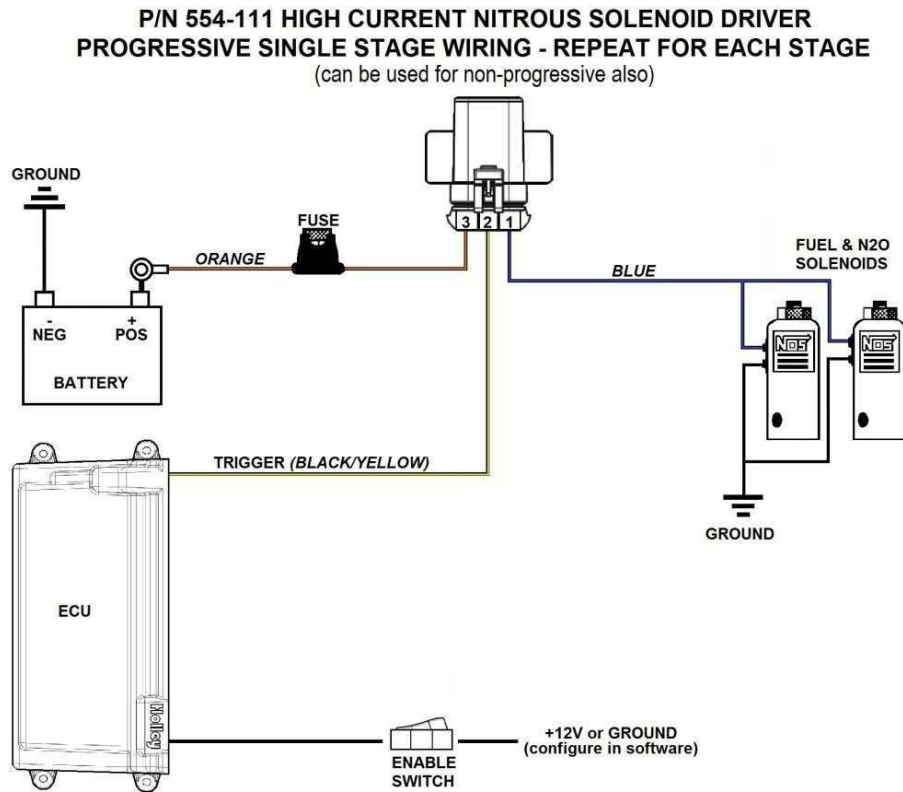

Figure 17

11.0 Water/Methanol System Wiring

The following reviews how to properly wire a water/methanol injection system being controlled by a HP or Dominator ECU.

11.1 Required Wiring

There are two “required” outputs when using the W/M control - the W/M solenoid and W/M pump activation outputs. They are wired as follows:

Water/Meth Solenoid - The solenoids must be operated by a peak-and-hold injector driver output. The first choice is to use a non-used injector driver output from the ECU. If one is not available, PN 554-113 must be used. This is a two channel driver to operate two water/meth solenoids. If using 554-113, see its instructions for details on wiring.

A harness should come with each Holley water/meth solenoid. It plugs directly into the solenoid, and is pinned to be installed into the ECU. When you enable the water/meth ICF, it will automatically assign injector driver output pins. Either look at the Pin Map under “View Injectors” or the “Inputs/Outputs” tab under the Water Meth ICF to see what pin is assigned for each solenoid(s).

The wiring harness included has a red wire going to pin A on the solenoid connector. This wire should go to the injector output on the ECU. It has an ECU pin already attached. An extra ECU pin is included if this wire needed to be shortened and re-terminated.

The blue wire in the harness needs to be connected to a +12v switched power source capable of handling 2A.

Water/Meth Pump Activation – An output is created that is used to trigger the relay that powers the water/meth pump. It can be configured as +12v or ground depending on how the relay is wired.

CAUTION! Do NOT wire directly to the W/M Pump!

11.2 Optional Wiring

W/M Manual Enable - This is an optional input. If enabled, connect to a switched +12v or ground input as configured in the software.

W/M Low Fluid Warnings – If the “Low Reservoir Warning Enabled” is selected, an input and output is created which are as follows:

W/M Low Fluid Input – This is the input from the fluid level sending unit that triggers the ECU as to a low fluid condition. Configure the software to whether this input is +12v or ground.

W/M Low Fluid Output – This is an output from the ECU that can be used to go to a warning lamp or any other device in the event of a low fluid condition.

12.0 Electronic Transmission Wiring

Holley Dominator EFI currently supports the use of 4L60E, 4L65E, 4L70E, 4L80E, and 4L85E transmissions. PN 558-505 is a fully terminated harness for these applications. The following reviews installation of this harness.

Main Transmission Connector – Simply plugs into the connector on the transmission. Located on the drivers side of a 4L80E (installed horizontally) and the passenger side on a 4L60E (installed vertically).

Vehicle Speed Sensor (VSS)/Transmission Output Speed Sensor (OSS) – Located on the rear drivers side on a 4L80E and the rear passengers side on a 4L60E

Input Shaft Speed (ISS) Sensor – The 4L60E does not have an ISS. It is located towards the front drivers side on a 4L80E. Note that a 4L70E has one internally wired, but is not connected to the HEFI harness. The ISS is not used for any calculations in the ECU, just for monitoring purposes.

Brake Switch (Grey) – Wired to the brake light switch. This must be installed to a +12v source (as most brake light switches are). This input is used to unlock the torque converter when the brakes are applied.

Ground (Black) – Connect to a good chassis/engine ground source

Power (Red) – Supplies power to the transmission solenoids. This should be connected to a +12v switched power source (must be capable of supplying 5 amps).

NOTE: The power supplying this wire must **NOT** be tied to the same point that the ECU switched power wire (red/white wire) is connected to. If they are tied together, the transmission power will back-feed power to the ECU and the ECU/engine will not shut off when the key is turned off. Use a relay or separate switched ignition power pickup point to supply power to the transmission harness.

See Figures 28 & 29 in 13.0 Wiring Appendix.

Holley Technical Support
1801 Russellville Road
Bowling Green, KY 42101
270-781-9741
www.holley.com

199R10555
5-10-11 wf

13.0 Wiring Appendix

271R960A
HOLLEY EFI MPFI
MAIN HARNESS
 (HARNESS ONLY SALES P/N 558-104)

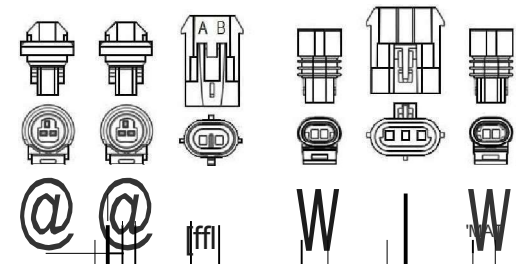

DESCRIPTION	COLOR	WIREGAUGE	PIN#
COIL-	YELLOW	22ga	A1
FUEL PUMP RELAY OUT (10A MAX)	RED	22 ga (if relay trigger)	A2
INPUT#2 (F, 5, 2, T, H, G)	WHITE/RED	22ga	A3
INPUT #4 (F, G, 5, 1)	WHITE/GREEN	22ga	M
TPS SIGNAL	GREEN	20ga	AS
POINTS OUTPUT	WHITE	18	A6
WBI COMPRI	BROWN	20ga	A7
WBI SHIELD	SHIELD	20ga	AS
WBIHTR	YELLOW	18ga	AQ
SWITCHED+12VIN	RED/WHITE	20ga	A10
MAT INPUT	BLUE	22ga	A11
INPUT#1 (F, 3, 2, T, H, G)	WHITE/BLUE	22ga	A12

INPUT #3 (F, G, 5)	WHITE/BLACK	22ga	A13
IPU GROUND	GREEN	22ga	A14
GAUGE OUTPUT	WHITE/BLACK	22ga	A15
WBI COMPRI	BROWN	20ga	A16
1 ROUND OUT	BLACK	20ga	A17
COOLANT TEMP IN	BLACK/WHITE	22ga	A18
COOLANT TEMP IN	BROWN	22ga	A18
OIL PRESSURE	GREY	22ga	A20
KNOCK #2 IN	BEIGE/RED	22ga	A21
CAM INPUT (DIG & IPU)	PURPLE	22ga	A22
MAP SENSOR SIGNAL	RED/BLACK	22ga	A23
CAN LO	ORANGE	22ga	A24
WBIVS+	RED	20ga	A25
SENSOR -SV REF OUT	ORANGE	22ga	A26
BYPASS OUT	BEIGE/BLACK	22ga	A21
EST/SPOUT OUT	BLUE/WHITE	22ga	A28
KNOCK#1 INPUT	BEIGE/BLUE	22ga	A29
CRANK INPUT (DIG & IPU)	PURPLE	22ga	A30
FUEL PRESSURE	PURPLE	22ga	A31
CAN HI	ORANGE/BLACK	22ga	A32
WBIP+	WHITE	20ga	A33
WBIHTR-	ORANGE	20ga	A34

DESCRIPTION	COLOR	WIREGAUGE	PIN#
IACALO			
IACAH			
PWM#4 OUT (G,P)			
INJECTOR F			
INJECTOR G			
INJECTOR H			
INJECTOR E			
IACB LO			
IACB HI			
PWM#3 OUT (G,P)			
PWM#2 OUT (H,P)			
PWM #1 OUT (H,P)			

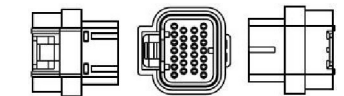
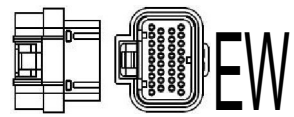
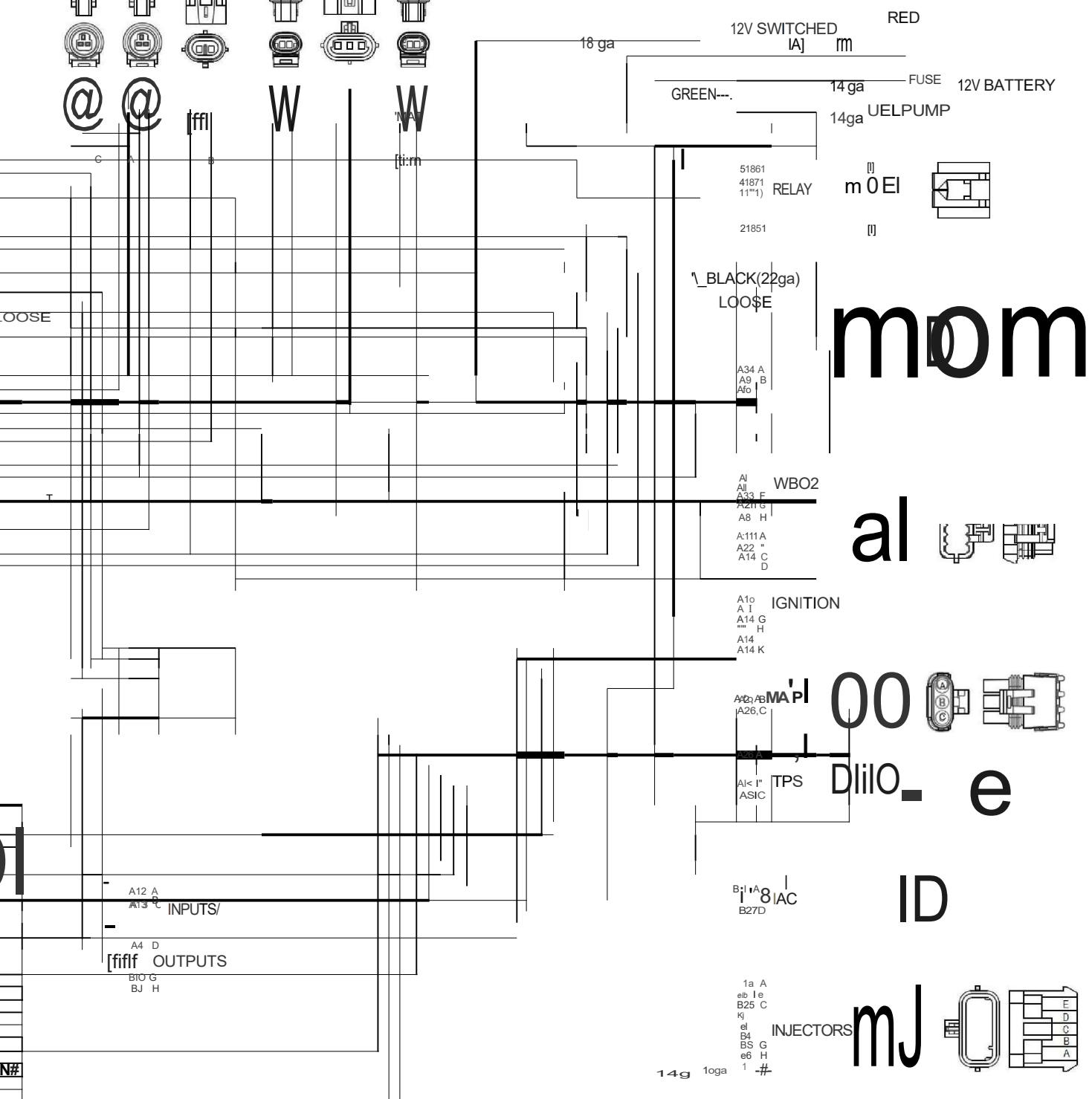

EST 4 (CYLINDER#4)
 EST 6 (CYLINDER#6)
 EST 8 (CYLINDER#8) INJECTOR A
 EST 12V OUT
 EST 1 (CYLINDER#1)
 EST 3 (CYLINDER#3)
 EST 5 (CYLINDER#5)
 EST 7 (CYLINDER#7) INJECTOR C INJECTOR B

PURPLE/BLUE PURPLE/YELLOW GREY/GREEN GREEN
 ORANGE BLUE PINK
 PURPLE/BLACK GREY/BLACK GREY/RED GREY/YELLOW PURPLE BLACK/YELLOW GREEN/WHITE
 ORANGE/WHITE BLUENIHITE PINK/WHITE GREY RED/YELLOW YELLOW/WHITE GREY/WHITE
 LIGHT/BLUENIHITE LIGHT/GREEN/WHITE BEIGE
 WHITE

22ga 22ga 20ga
 20ga 20ga 20ga
 20ga 22ga uga
 20ga 20ga 20ga
 20ga 20ga 22ga
 22ga 22ga 22ga
 20ga 20ga 21ga
 22ga 22oa 22ga
 20ga 20ga

B
 I
 B
 2
 B
 J
 B
 4
 B
 S
 B
 6
 B
 I
 B
 B
 B
 9
 B
 1
 0
 B
 1
 1
 B
 I
 2
 B
 1
 3
 B
 1
 4
 B
 1
 5
 B
 1
 6
 B
 1
 7
 B
 1
 S
 B
 1
 9
 B
 2
 0
 B
 2
 1
 B
 2
 2
 B
 2
 3
 B
 2
 4
 B
 2
 5
 B
 2
 6

I
 J
 1
 6
 g
 a

R
 E
 D

L
 O
 O
 S
 E
 B
 L
 A
 C
 K
 2
 0
 g
 a

Figure 18

271R960A HOLLEY EFI MPFI MAIN HARNESS

(HARNESS ONLY SALES P/N 558-104)

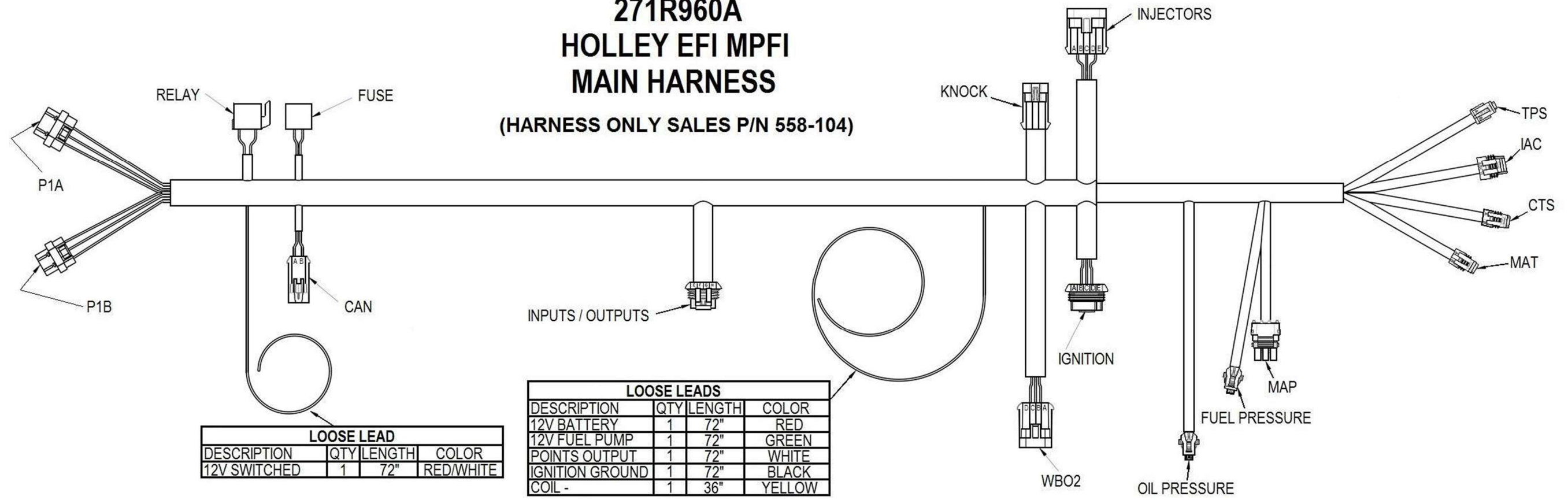

Figure 19

**271R961A
HOLLEY EFI 4BBL
TBI HARNESS**
(HARNESS ONLY SALES P/N 558-100)

IDI
m

SD

a QI
(1

DESCRIPTION	COLOR	WIRE GAUGE	PIN#	FUEL	CAN	CTS	MAT
	YELLOW	22ga	A1				
ALL PUMP RELAY OUT (10A MAX) INPUT #2 (F,5,2,T,H,G) INPUT #4 (F,G,5)	WHITE/RED WHITE/GREEN	??ga 22ga (#22gauge trigger)	A3 A4				
TPS SIGNAL	GREEN	20ga	A5				
POINTS OUTPUT	WHITE	18 ga	A6				
WBI COMP2	BROWN	20ga	A7				
WBI SHIELD	SHIELD	20ga	NJ				
WBI HTR	YELLOW	18 ga	A9				
SWITCHED >12V IN	RED/WHITE	20ga	A10				
MAT INPUT	BLUE	20ga	A11				
INPUT #1 (F,5,2,T,H,G)	WHITE/BLUE	22ga	A12				
IPU GROUND	WHITE/BLACK	22ga	A13				
GAUGE OUTPUT	GREEN	22ga	A14				
WBI COMP1	WHITE/BLACK	22ga	A15				
WBIVS-<IP	BROWN	20ga	A16				
SENSOR GROUND OUT	BLACK	20ga	A17				
CONDUTAN(F3)EIMPIN	BLACK/WHITE	22 ga	A18				
OIL PRESSURE	BROWN	22ga	A19				
KNOCK#2 IN	GREY	22ga	A20				
CAM INPUT (DIG & IPU) / BYPASS	BEIGE/RED PURPLE	22 ga 2 ga	A21 A22				
MAP SENSOR SIGNAL	REDBLACK	22ga	A23				
CAN LO	ORANGE	22 ga	A24				
WBIVS->	RED	20ga	A25				
SENSOR .5y REF OUT	ORANGE	22ga	A26				
NOTUSED	BEIGE/BLACK	22ga	A27				
EST/SPOUT OUT	BLUE/WHITE	22 ga	A28				
KNOCK# INPUT	BEIGE/BLUE	22ga	A29				
CRANK INPUT (DIG & IPU)	PURPLE	22ga	A30				
FUEL PRESSURE	PURPLE	22ga	A31				
CAN HI	PURPLE	22ga	A32				
WBIIP+	ORANGE/BLACK	22ga	A33				
WBIHTR+	WHITE ORANGE	20ga 22ga	A34				

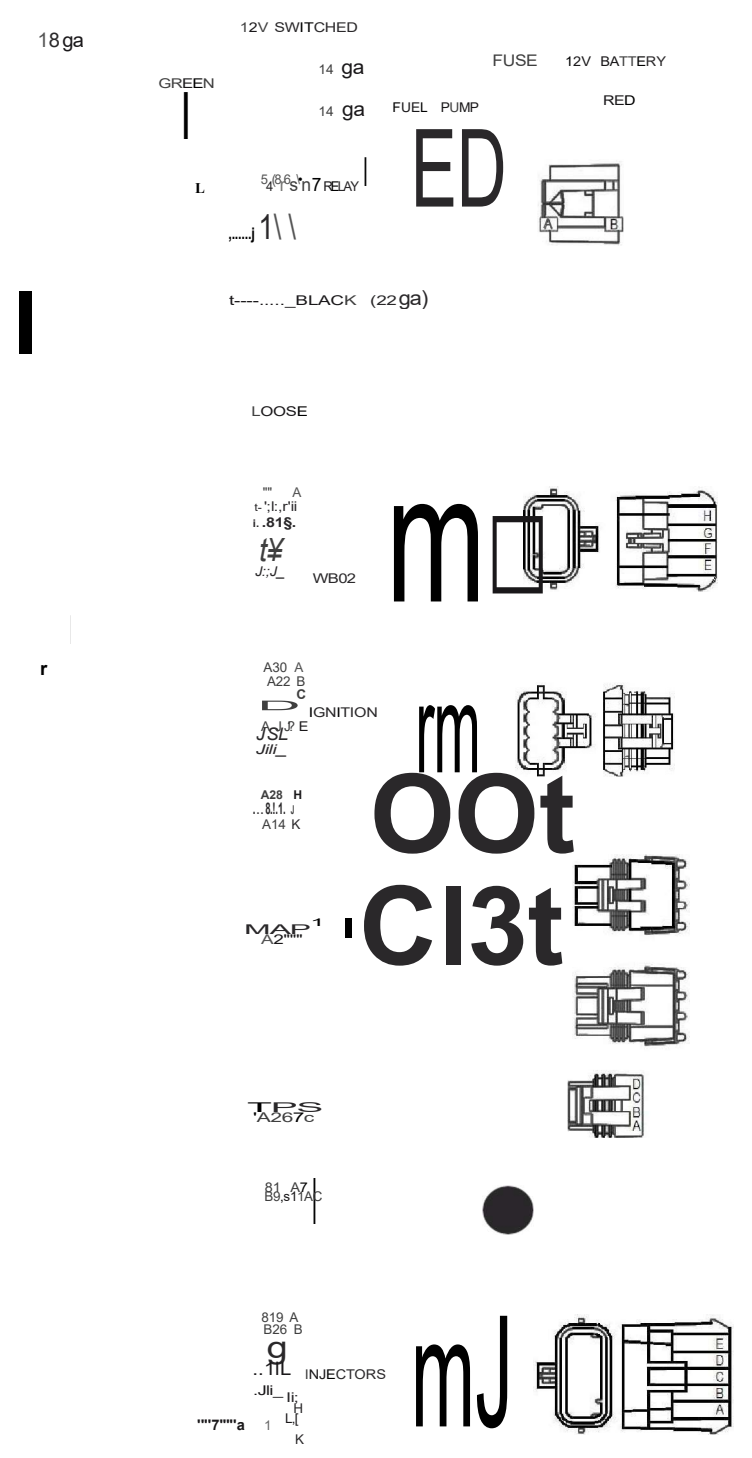
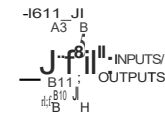

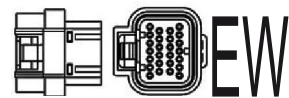

LA CALO	PURPLE/BLUE	22na	B1
LA GAHI	PURPLE/YELLOW	22ga	B2
PWM#4 OUT (G,P-)	GREY/GREEN	20ga	B3
INJECTORF	GREEN	20ga	B4
INJECTORG	ORANGE	20ga	B5
INJECTORH	BLUE	20ga	B6
INJECTORE	PINK	20ga	B7
L/CBLO	PURPLE/WHITE	22ga	B8
L/CBHI	PURPLE/BLACK	22ga	B9
PWM#3 OUT (G,P)	GREY/BLACK	20ga	B10
PWM#2 OUT (H,P-)	GREY/RED	20ga	B11
PWM#1 OUT (H,P-)	GREY/YELLOW	20ga	B12
INJECTOR D	PURPLE	20ga	B13
EST GROUND OUT	BLACK/YELLOW	20ga	B14
EST 2 (CYLINDER#2)		2 ga	B15
EST 4 (CYLINDER#4)		22ga	B16
EST 6 (CYLINDER#6)		22ga	B17
EST 8 (CYLINDER#8)		22ga	B18
INJECTOR A	GREY	20ga	B19
EST 12V OUT	RED/YELLOW	20ga	B20
EST 1 (CYLINDER#1)		22ga	B21
EST 3 (CYLINDER#3)		22ga	B22
EST 5 (CYLINDER#5)		22ga	B23
EST 7 (CYLINDER#7)		22ga	B24
INJECTOR C	BEIGE	20ga	B25
INJECTOR B	WHITE	20ga	B26

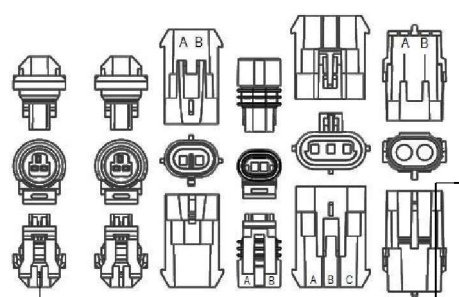

WV:ED

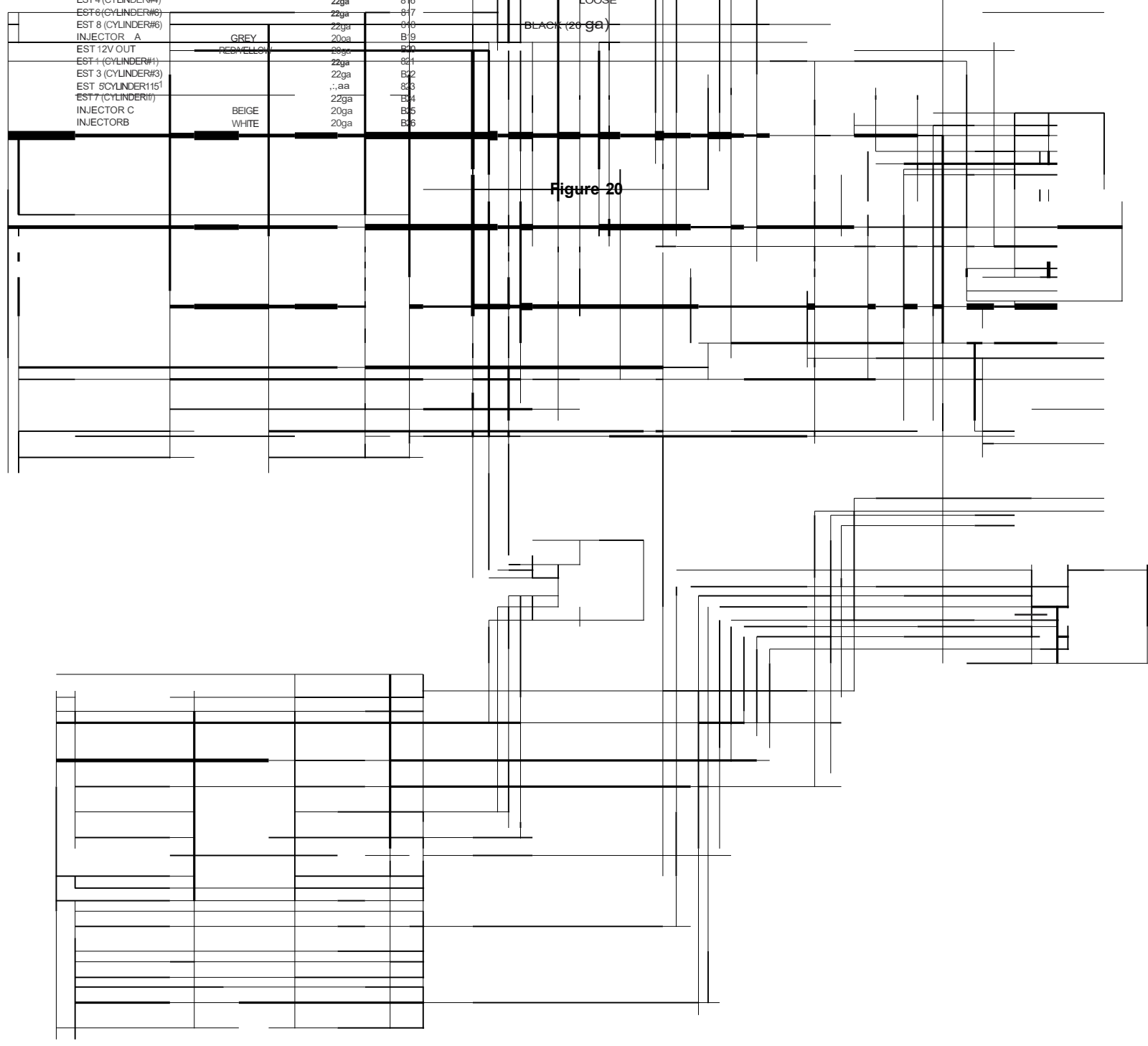

271R961A HOLLEY EFI 4BBL TBI HARNESS (HARNESS ONLY SALES P/N 558-100)

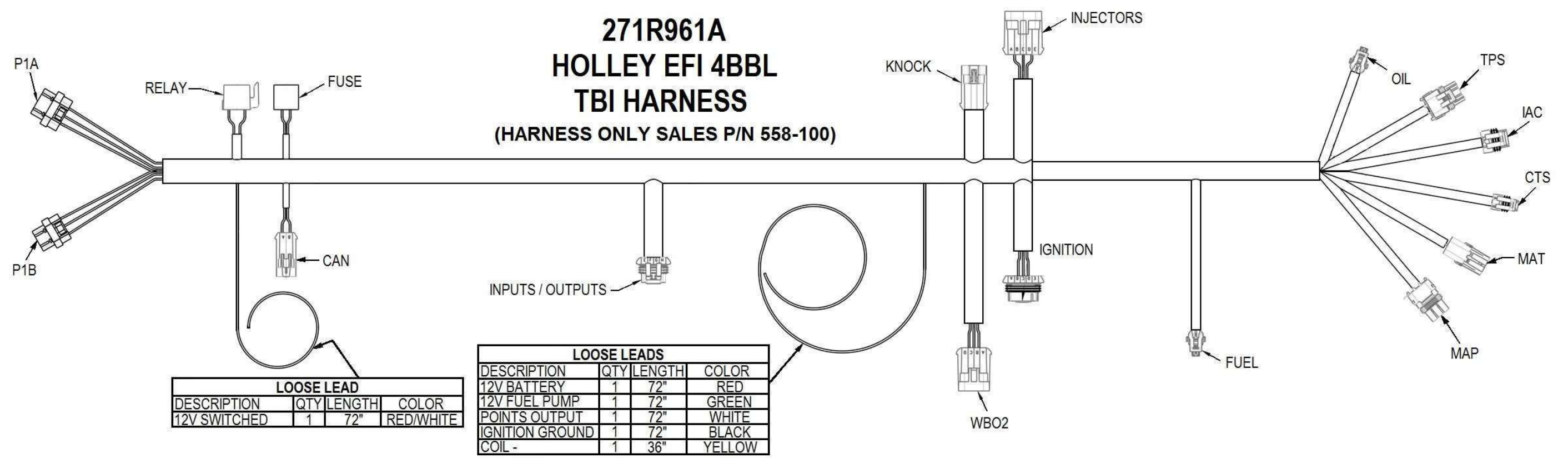

Figure 21

**271R962A
LS2 MAIN HARNESS
(HARNESS ONLY SALES P/N 558-103)**

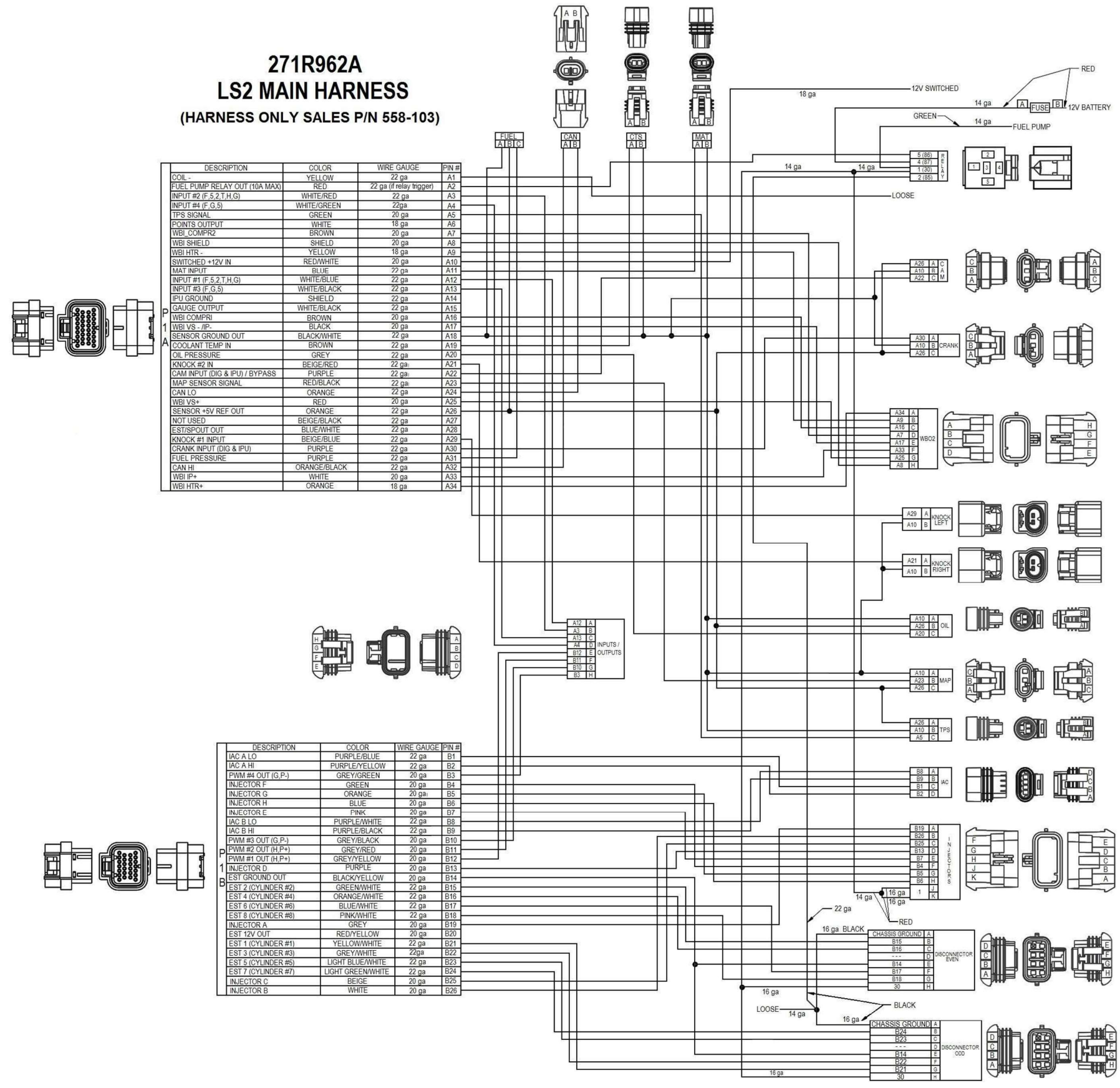

Figure 22

**271R962A
LS2 MAIN HARNESS**
(HARNESS ONLY SALES P/N 558-103)

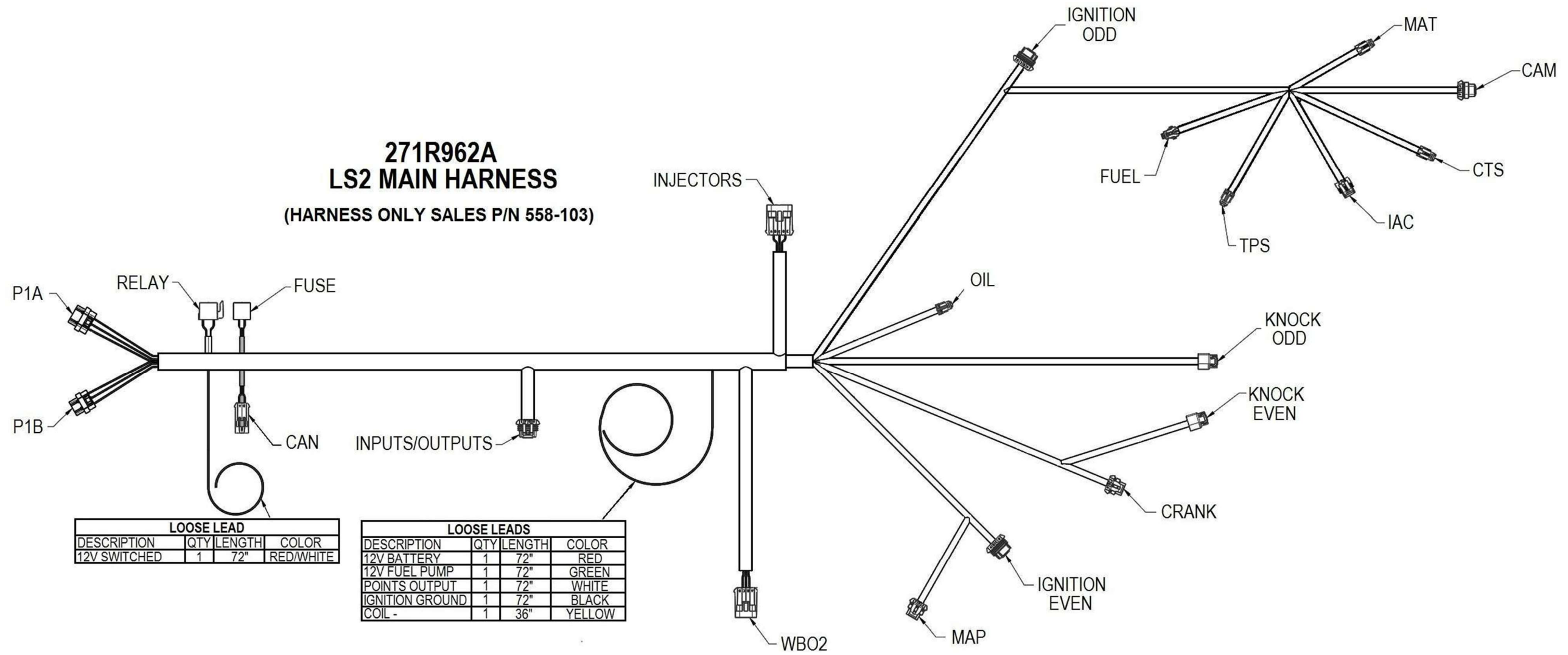
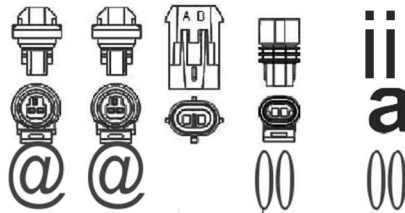

Figure 23

271R968A
LS1 MAIN HARNESS
 (WIRING HARNESS SALES P/N 558-102)



DESCRIPTION	COLOR	WIRE GAUGE	PIN#
COIL	YELLOW	22ga	A1
FUEL PUMP RELAY OUT (110A MAX)	RED	22ga	A2
INPUT#2 (F.5.2.T.H.G)	WHITE/GREEN	22ga	A3
INPUT#4 (F.G.5)	WHITE/GREEN	22ga	M
TPS SIGNAL	GREEN	20ga	A5
POINTS OUTPUT	WHITE	18ga	A6
WBI COMP R2	BROWN	20ga	A7
WBI SHIELD	SHIELD	20ga	A8
WBI HTR	YELLOW	18ga	A9
MAT INPUT	BLUE	22ga	A11
INPUT#1 (F.5.2.T.H.G)	WHITE/BLUE	22ga	A12
INPUT#3 (F.G.5)	WHITE/BLACK	22ga	A13
IPU GROUND	BLACK/SHIELD	22ga	A14
GAUGE OUTPUT	WHITE/BLACK	22ga	A15
WBI COMP R1	BROWN	20ga	A16
WBI SHIELD	BLACK	20ga	A17
SENSOR GROUND OUT	BLACK/WHITE	22ga	A18
COOLANT TEMP IN	BROWN	22ga	A19
OIL PRESSURE	GREY	22ga	A20
A KNOCK #2 IN	BEIGE/RED	22ga	A21
CAM INPUT (DK. & IPU) / BYPASS	PURPLE	22ga	A22
MAP SENSOR SIGNAL	RED/BLACK	22ga	A23
CAN LO	ORANGE	22ga	A24
WBI S+V	RED	20ga	A25
SENSOR +SV REF OUT	ORANGE	22ga	A26
NOT USED	BEIGE/BLACK	22ga	A27
EST/SPOUT OUT	BLUE/WHITE	22ga	A28
KNOCK #1 INPUT	BEIGE/BLUE	22ga	A29
CRANK INPUT (DIG & IPU)	PURPLE	22ga	A30
FUEL PRESSURE	PURPLE	22ga	A31
CAN HI	ORANGE/BLACK	22ga	A32
WBI P+	WHITE	20aa	A33
WBI HTR+	ORANGE	18ga	A34

DESCRIPTION	COLOR	WIRE GAUGE	PIN#
IACALO	PURPLE/BLUE	22ga	B1
IAC AH	PURPLE/YELLOW	22ga	B2
PWM #4 OUT (G.P)	GRAY/GREEN	20 aa	B3
INJECTOR F	GREEN	20 ga	B4
INJECTOR G	ORANGE	20 ga	B5
INJECTOR H	BLUE	20 ga	B6
INJECTOR E	PINK	20 ga	B7
IAC BLO	PURPLE/WHITE	22ga	B8
IAC BH	PURPLE/BLACK	22 ga	B9
PWM #3 OUT (H.P)	GRAY/BLACK	20 ga	B10
PWM #2 OUT (H.P)	GRAY/RED	20 ga	B11
PWM #1 OUT (H.P)	GRAY/YELLOW	20 ga	B12
INJECTOR D	PURPLE	20 ga	B13
EST GROUND OUT	BLACK/YELLOW	20 ga	B14
EST 2 (CYLINDER#2)	GREEN/WHITE	22aa	B15
EST 4 (CYLINDER#4)	ORANGE/WHITE	21ga	B16
EST 6 (CYLINDER#6)	BLUE/WHITE	22ga	B17
EST 8 (CYLINDER#8)	PINK/WHITE	22ga	B18
INJECTOR A	GRAY	20aa	B19
EST 12V OUT	RED	20 ga	B20
EST 1 (CYLINDER#1)	YELLOW/WHITE	22ga	B21
EST 3 (CYLINDER#3)	GRAY/WHITE	22aa	B22
EST 5 (CYLINDER#5)	LIGHT BLUE/WHITE	27ga	B23
EST 7 (CYLINDER#7)	LIGHT BLUE/WHITE	22ga	B24
INJECTOR C	BEIGE	20 aa	B25
INJECTOR B	WHITE	20 aa	B26

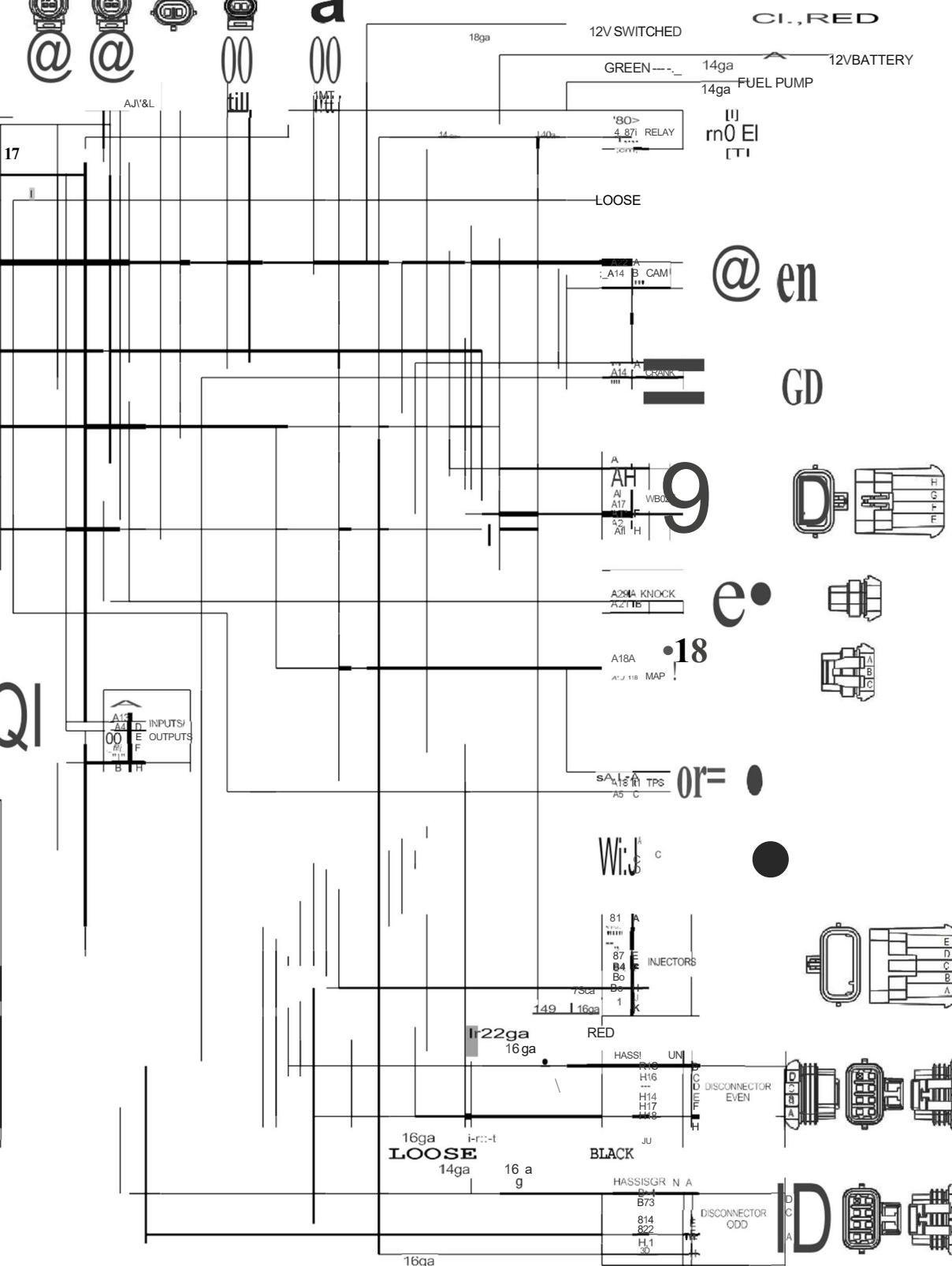
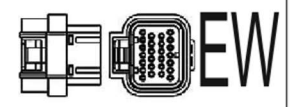
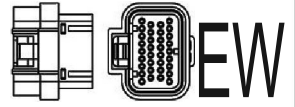

Figure 24



271R968A LS1 MAIN HARNESS

(WIRING HARNESS SALES P/N 558-102)

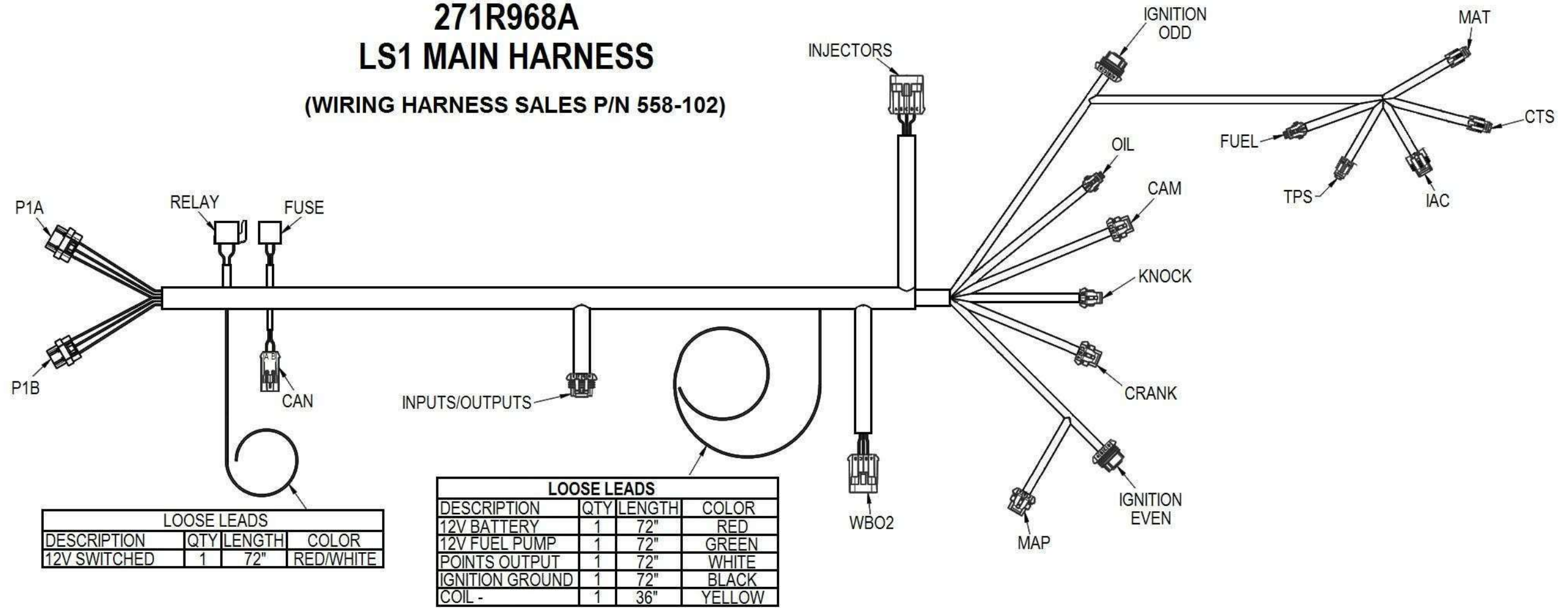

Figure 25

271R973A HOLLEY EFI STEALTHRAM & TPI

(WIRING HARNESS ONLY SALES P/N 558-101)

DESCRIPTION	COLOR	WIREGAUGE	PIN#
COIL	YELLOW	22ga	A1
FUEL PUMP RELAY OUT (10A MAX)	RED	22ga (if relay bigger)	A2
INPUT #2 (F,5,2,T,H,G)	WHITE/RED	22ca	A3
INPUT #4 (F,G,5)	WHITE/GREEN	22ga	A4
TPS SIGNAL	GREEN	20ga	A8
POINTS OUTPUT	WHITE	18ga	A6
WBI COMPR2	BROWN	21 ga	A1
WBI SHIELD	SHIELD	20ca	A8
WBI HTR	YELLOW	18aa	A9
SWITCHED 12V IN	RED/WHITE	20ga	A10
MAT INPUT	BLUE	22ga	A11
INPUT #1 (F,5,2,T,H,G)	WHITE/BLUE	22ga	A12
INPUT #3 (F,G,5)	WHITE/BLACK	22ga	A13
IPUGROUND	GREEN	22ga	A14
GAUGE OUTPUT	WHITE/BLACK	22ga	A15
WBI COMPR1	BROWN	20ga	A1B
WBI IN 1-ROUNDOUT	BLACK	20ca	A17
COOLANT TEMP IN	BLACK/WHITE	2L ga	A1S
OIL PRESSURE	BROWN	22ga	A19
	GREY	22ga	A20
KNOCK#2 IN	BEIGE/RED	22ga	A21
CAM INPUT DIG & IPU / BYPASS	PURPLE	22i:ia	A22
MAP SENSORSIGNAL	RED/BLACK	22aa	A23
CAN LO	ORANGE	22ga	A24
WBI VS	RED	20ga	A25
SENSOR SV REF OUT	ORANGE	22oa	A26
NOT USED	BEIGE/BLACK	22ga	A21
EST/SPOUT OUT	BLUENHITE	22ca	A28
KNOCK #1 INPUT	BEIGE/BLUE	22ca	A29
CRANK INPUT (DIG & IPU)	PURPLE	22ga	A30
FUEL PRESSURE	PURPLE	22ga	A31
CAN HI	ORANGE/BLACK	22ga	A32
WBI IP	WHITE	20ga	A33
WBI HTR	ORANGE	foga	A14

e (J au

DESCRIPTION	COLOR	WIREGAUGE	PIN#
IACALO	PURPLE/BLUE	22ga	B1
IACAH	PURPLE/YELLOW	22ga	B2
PWM#4 OUT (G,P)	GREY/GREEN	20aa	B3
INJECTORF	GREEN	20aa	B4
INJECTORG	ORANGE	20ca	B5
INJECTORH	BLUE	10 ga	B6
INJECTORE	PINK	20ga	B1
IAC B LO	PURPLE/WHITE	22aa	B8
IAC B HI	PURPLE/BLACK	22ga	B9
PWM#3 OUT (G,P)	GREY/BLACK	20ga	B10
PWM112 OUT (H,P)	GREY/RED	20ga	B11

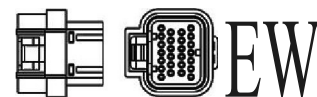

Fillcl
A B

A B A B C A B

OOE rs-CK mn

Lfi12.1A
A3 B
1.1 1 1 INPUTS/
B12 OUTPUTS
B1 1 1 It
B3 H

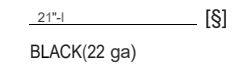
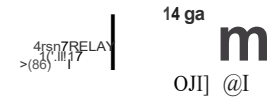
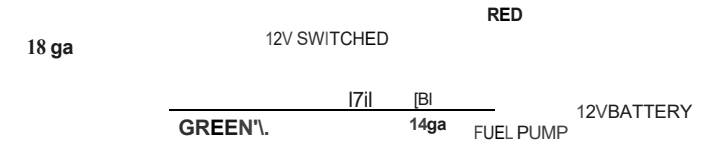

LOOSE



IGNITION
A14 G
A14 UJ
A14 J
A14 K



LOOSE
BLACK
20 ga

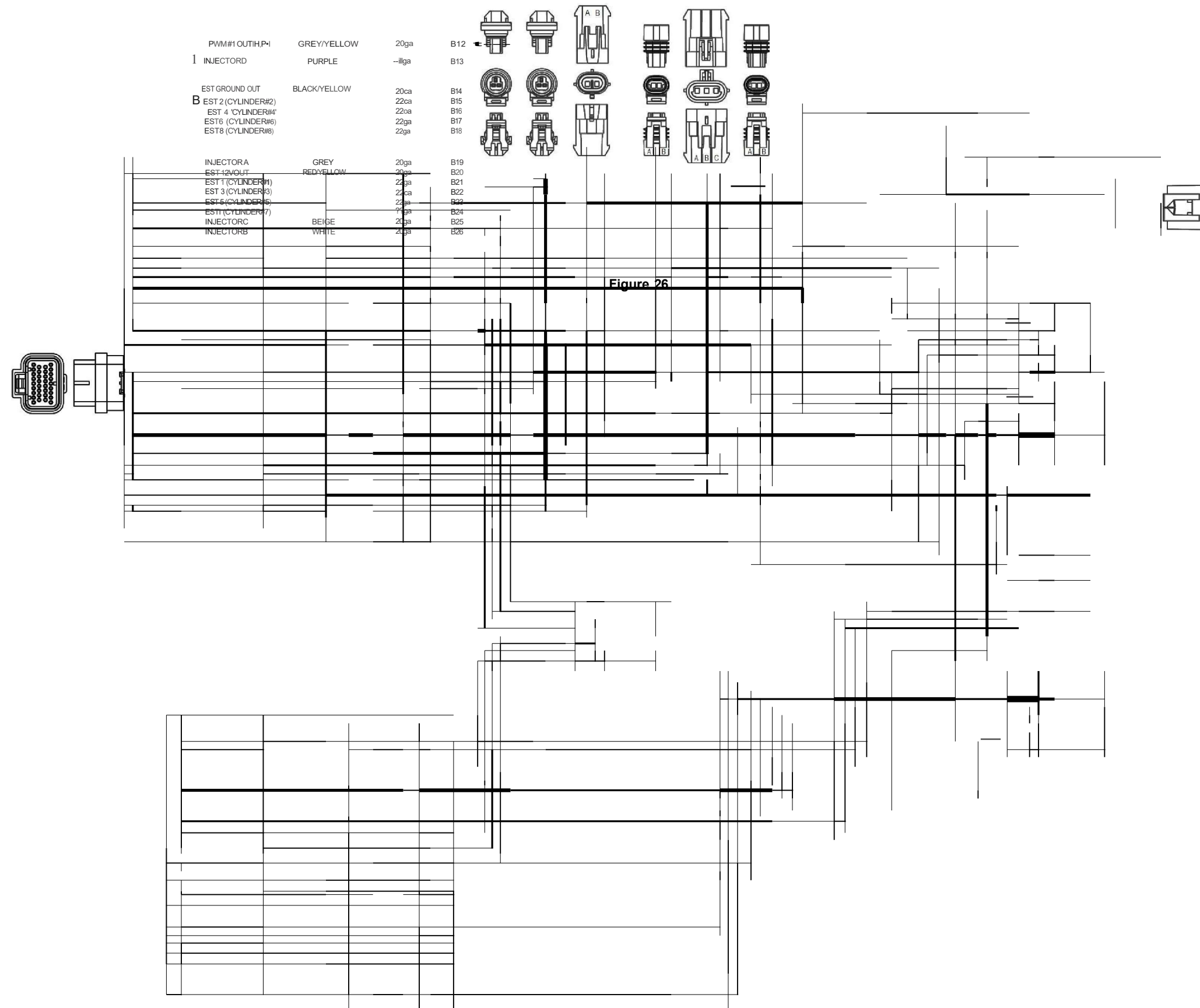

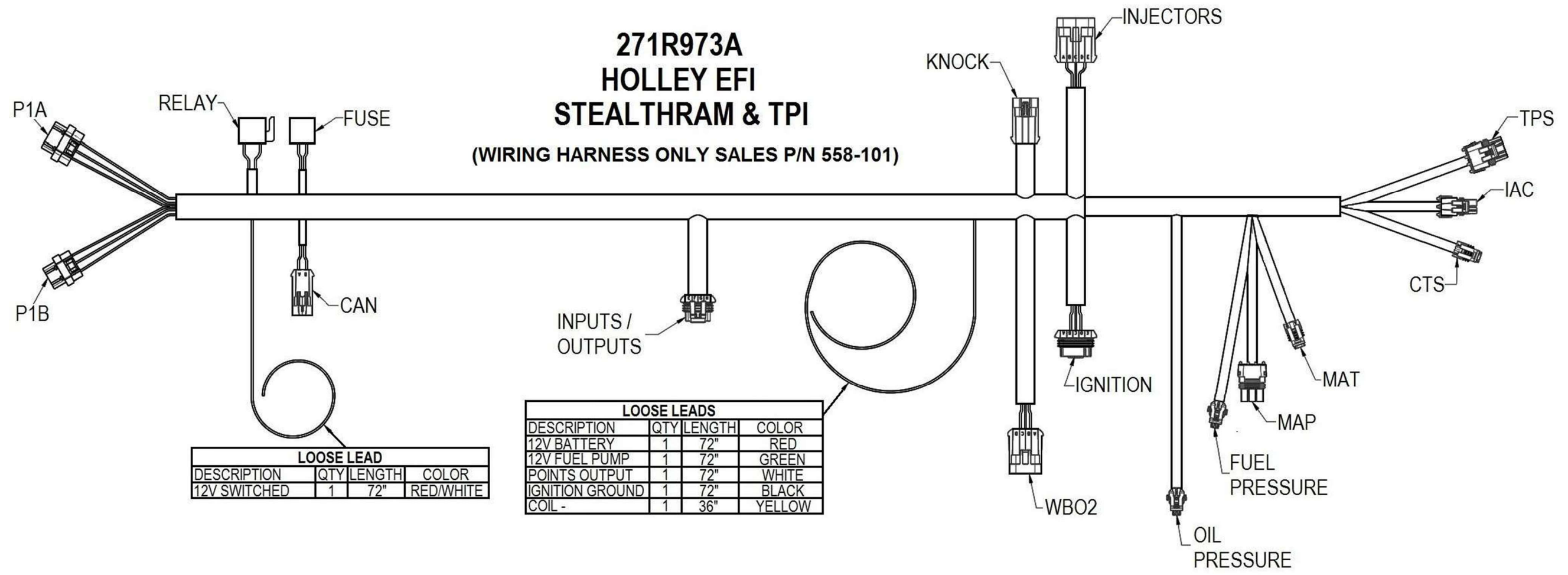

Figure 27

271R974A GM 4L60-4L80E TRANSMISSION HARNESS

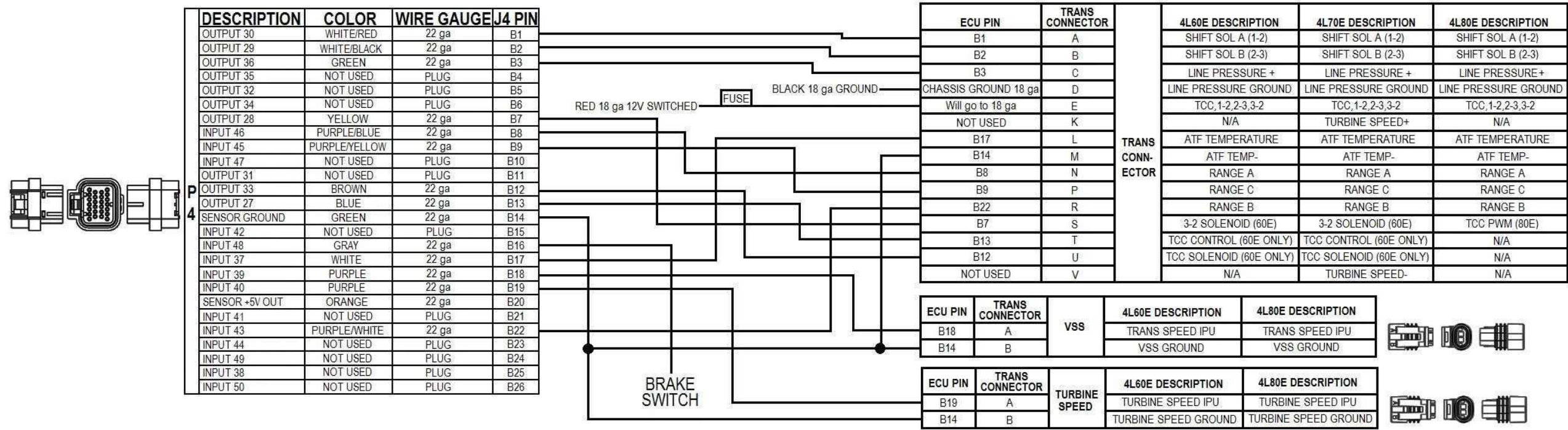

Figure 28

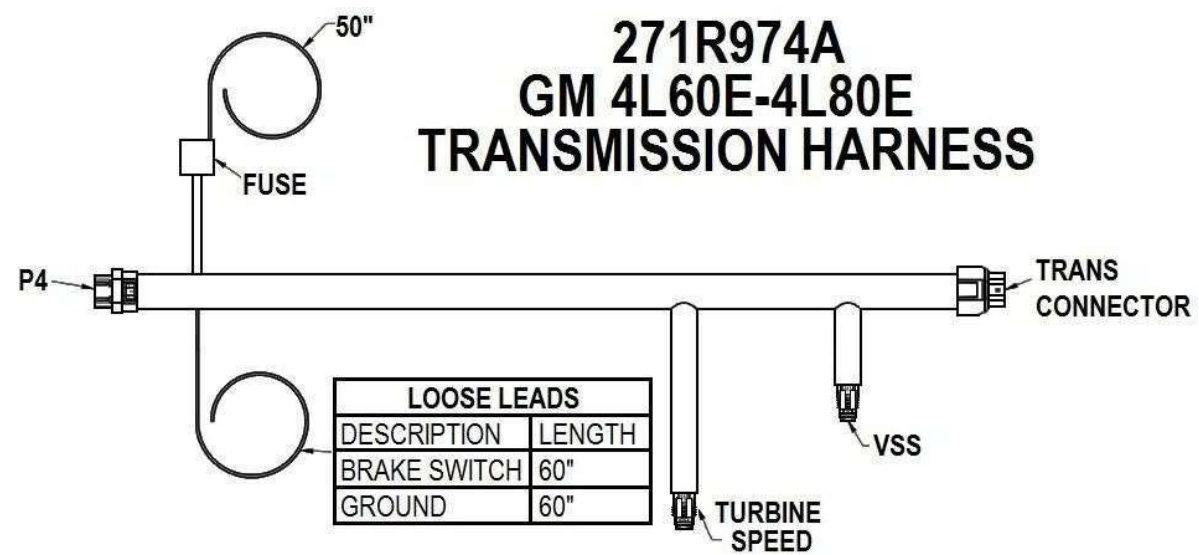

Figure 29

**271R998A
HOLLEY EFI
2BBL TBI HARNESS**

t t\iJ100@

i ® m- I

12V SWITCHED FUSE

12V BATTERY

RED

6

1Bga GREEN...N... ifi R-E...i 14*a,a,m;UMP

7 'ii;1 :J

LOOSE

1 BLACK 22 ga

IC

DESCRIPTION
: @=FW.IBR3E GIAU G E2P1iN #

DESCRIPTION	COLOR	WIRE GAUGE	PIN #
POINTS OUTPUT	BROWN	20ga	A8
WBI COMPR2	WHITE/GREEN	18 ga	A9
WBI VS /IP	BLACK	20 ga	A10
SWITCHED 12V IN	RED/WHITE	20 ga	A11
MAT INPUT	BLUE	22 ga	A12
INPUT #1 (F, S, 2, T, H, G)	WHITE/BLUE	22 ga	A13
INPUT #3 (F, G, S)	WHITE/BLACK	22 ga	A14
IPU GROUND	GREEN	22 ga	A15
GAUGE OUTPUT	WHITE/BLACK	22 ga	A16
WBI COMPR1	BROWN	20 ga	A17
WBI VS /IP	BLACK	20 ga	A18
SENSOR GROUND OUT	BLACK/WHITE	22 ga	A19
COOLANT TEMP IN	BROWN	22 ga	A20
OIL PRESSURE	GREY	22 ga	A21
KNOCK #2 IN	BEIGE/RED	22 ga	A22
CAM INPUT (DIG & IPU) / BYPASS	PURPLE	22 ga	A23
MAP SENSOR SIGNAL	RED/BLACK	22 ga	A24
CAN LO	ORANGE	20 ga	A25
	ORANGE	22 ga	A26

NOTUSED	BEIGE/BLACK	22 ga	A28
EST/SPOUTOUT	BLUE/WHITE	2 ga	A30_1
KRONAN/RUN/IDG & IPU)	PURPLE	22ga	A33_1
FUEL PRESSURE	ORANGE/BLACK	220ga	L
CAN HI	WHITE	18 ga	
BI HTR+	ORANGE		

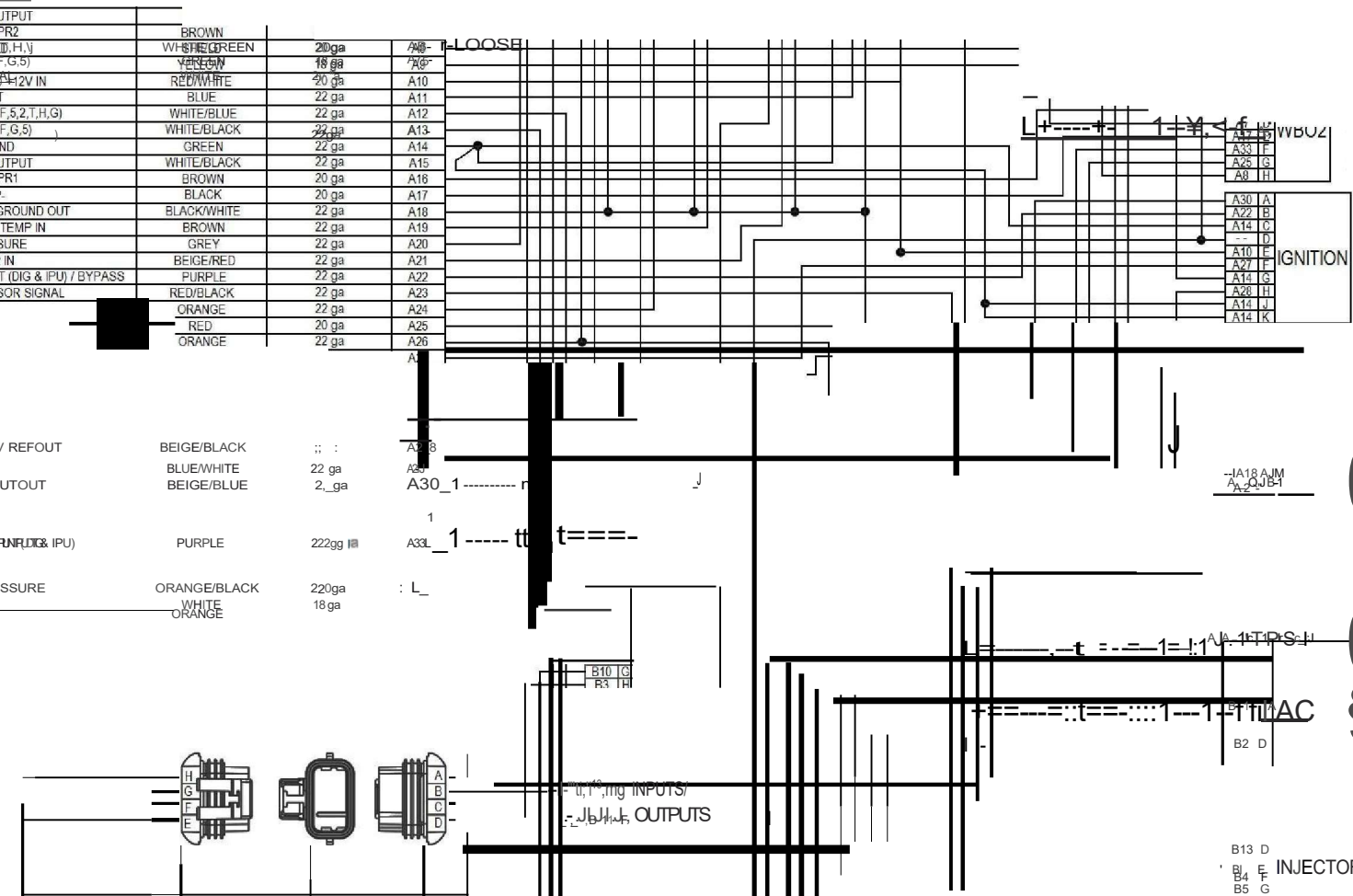

DESCRIPTION	COLOR	WIRE GAUGE	PIN #
IACALO	PURPLE/BLUE	22ga	B1
IACAH1	PURPLE/YELLOW	22ga	B2
PWM #4 OUT (G,P1)	GREY/GREEN	20ga	B3
INJECTOR#1	INJECTOR#1		
INJECTOR#2	EST 12V OUT		
INJECTOR#3	EST 1		
INJECTOR#4	(CYLINDER#1)		
INJECTOR#5	EST 3 (CYLINDER#3)		
IAC B LO	EST 5 CYLINDER		
IAC B HI	#3		
PWM #3 OUT (G,P1)	#5		
PWM #2 OUT (H,P+)			
PWM #1 OUT (H,P+)			
INJECTOR#6			
EST GROUND OUT			
EST 2 (CYLINDER#2)			
EST 4 (CYLINDER#4)			
EST 6 (CYLINDER#6)			
EST 8 (CYLINDER#8)			

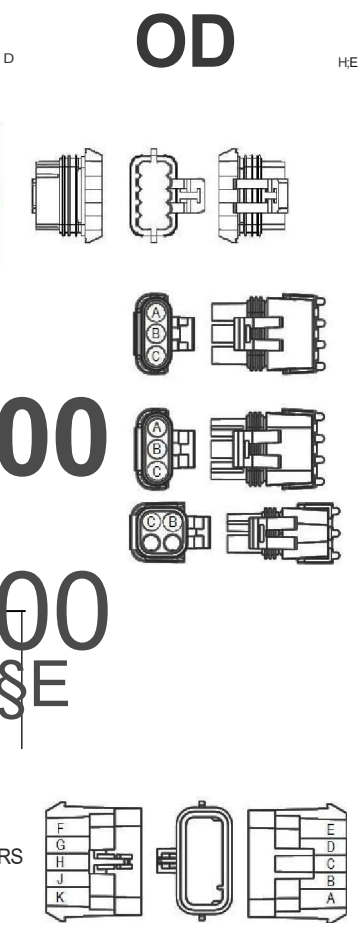

G9Effi

B4 B5 B6
B1 B5 B9 BIO B11 B12 B13 B14 B15 B16 B17 B18 B19 B20_ B21 B22 B23

J
J

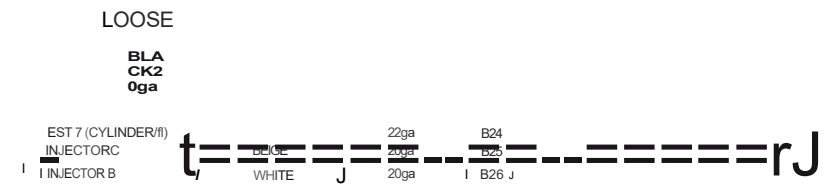

Figure 30

271R998A HOLLEY EFI 2BBL TBI HARNESS

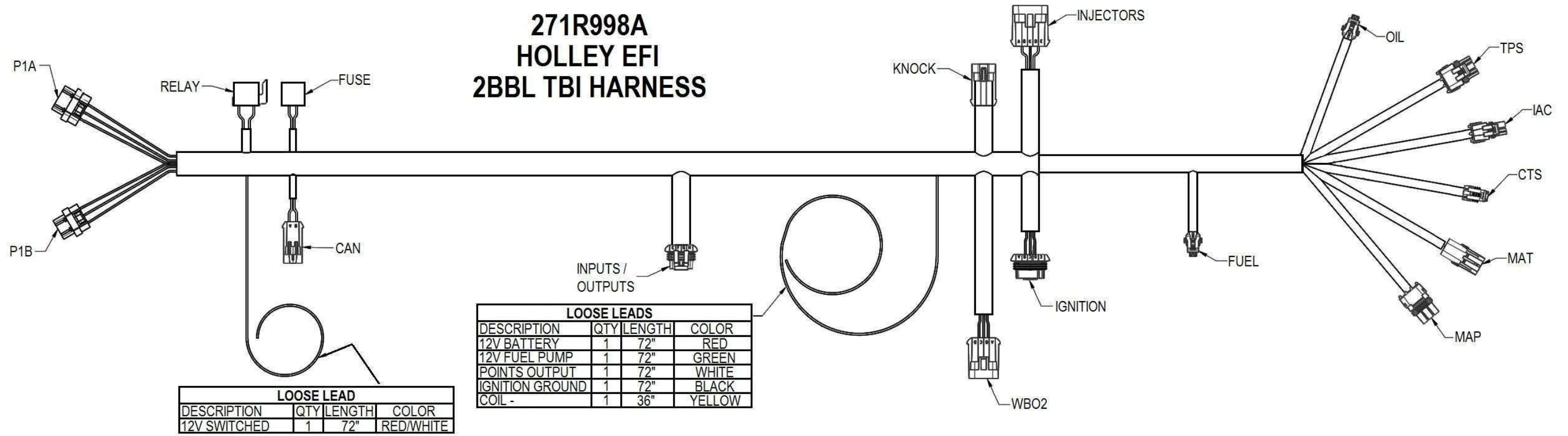

Figure 31

HOLLEY TECHNICAL SUPPORT
1801 Russellville Road
Bowling Green, KY 42101
270-781-9741
www.holley.com

199R10555
 5-10-11 wf

Injector Flow Matching Example Documentation

Holley® EFi

ELECTRONIC FUEL INJECTION

PART #: 522-568

SERIAL #: XXXXX

DESIGN FLOW: 1650 cc/min

Injector Valve Type: Stainless Steel

Impedance: High 8.5 Ohm

Data Match Technology

Test conditions information:

Test fluid: Gasoline

Test fluid temp: 88-91 °F / 32°C

Test Bench Injector Driver - OEM Denso ECU

Slope Flow Matching Data

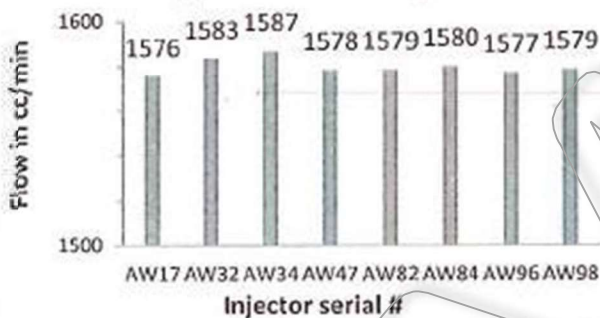

Average Flow rate at 43.5 psi: **1581 cc/min**

Your set is flow matched within **0.7%**

Matching individual injector dynamic flow rates, called the slope of the injector, results in matched AFR's benefitting good idle, cruise and startup.

Injector Offset Matching Data

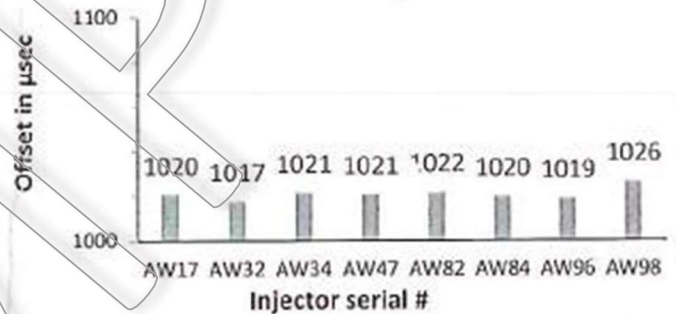

Average Offset at 3 bar & 13.5V: **1020 µs**

Your set is offset matched within **0.5%**

Offset/ latency matching ensures that all injectors pulse the same amount of fuel at all pulse widths, which is especially critical at the short idle pulses.

Injector Voltage Offset values in milliseconds (1ms=1000µs)

Base Fuel Pressure in psi/bar

		43.5 psi 3.0 bar	58.0 psi 4 bar	72.5 psi 5.0 bar	87.0 psi 6.0 bar
Flow at each pressure →		1581 cc/min	1825 cc/min	2040 cc/min	2235 cc/min
System / ECU voltage at injector	8 Volt*	2.70 ms	3.67 ms	*	*
	10 Volt	1.78 ms	2.11 ms	2.62 ms	6.03 ms
	12 Volt**	1.30 ms	1.50 ms	1.74 ms	2.06 ms
	14 Volt**	0.99 ms	1.18 ms	1.30 ms	1.40 ms
	16 Volt	0.75 ms	0.93 ms	1.02 ms	1.00 ms

*Injectors may not pulse at low voltage & high pressure

**Typical operating voltage zone of a running engine.

Throttle Body Specifications

PRODUCTION PART NO.

L12R47

**NOT
RELEASED,
FOR QUOTING
OR ESTIMATE ONLY**

LAST DATE SAVED

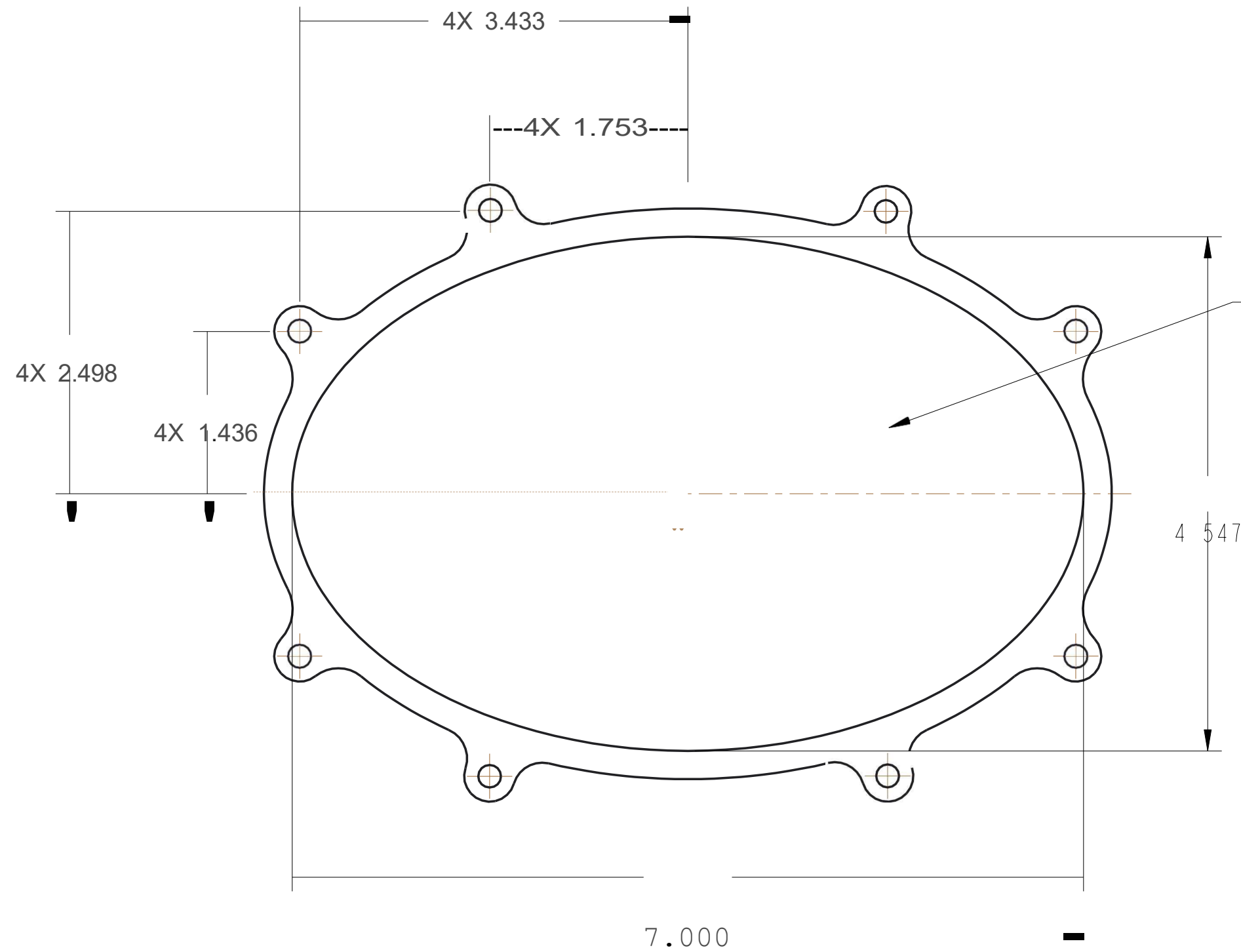

OVAL PRO STOCK THROTTLE BODY
ADAPTER (COLD PIPE) SIDE
1.D. 25.00 SQUARE INCHES

REL	REV	A.P.C.N.	DATE	DRAWN	APPROVED

REVISION HISTORY	
FINISH	MATERIAL
APPLICABLE SPECIFICATIONS	SHEET
S-1000	of
PRODUCTION PART NO.	SCALE
L12R47	0.500
DESCRIPTION	B
FOR GEOMETRY REFERENCE ONLY	Holley
COMPANY CONFIDENTIAL	Pro/ENGINEER

THE INFORMATION CONTAINED ON THIS DRAWING IS PROPRIETARY AND CONFIDENTIAL. IT IS THE SOLE PROPERTY OF HOLLEY PERFORMANCE PRODUCTS INC. ANY DUPLICATION OR TRANSMISSION OF THIS INFORMATION WITHOUT WRITTEN AUTHORIZATION IS STRICTLY PROHIBITED.

MENSIONS AND TOLERANCING CONFORM TO
ASME Y14.5-2009



THIRD ANGLE PROJECTION

PRODUCTION PART NO.

L12R46

**NOT
RELEASED,
FOR QUOTING
OR ESTIMATE ONLY**

LAST DATE SAVED

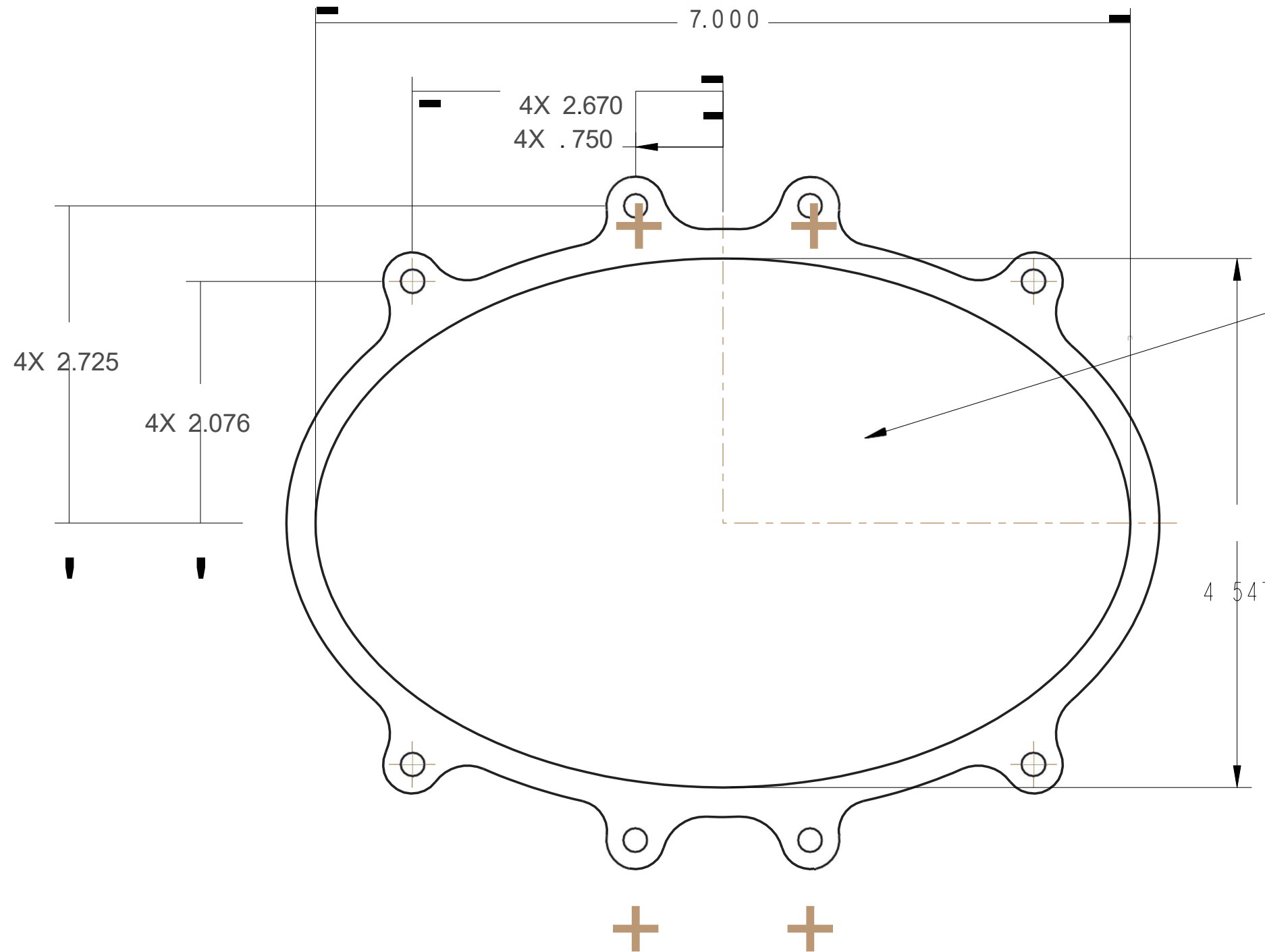

OVAL PRO STOCK THROTTLE BODY
MANIFOLD SIDE
I. D. 25.00 SQUARE INCHES

REV	A.P.C.N.	DATE	DRAWN	APPROVED
REVISION HISTORY				
FINISH		MATERIAL		
APPLICABLE SPECIFICATIONS		SHEET		
S- 1000		of		
PRODUCTION PART NO.		SCALE	SIZE	
L12R46		0.500	B	
DESCRIPTION		 <small>HOLLEY PERFORMANCE PRODUCTS, INC. 1501 - RUSSELLVILLE RD. BOWLING GREEN, KY 42101 (270) 782-2900</small>		
FOR GEOMETRY REFERENCE ONLY				
COMPANY CONFIDENTIAL		Pro/ENGINEER		

THE INFORMATION CONTAINED ON THIS DRAWING IS
PROPRIETARY AND CONFIDENTIAL. IT IS THE SOLE PROPERTY
OF HOLLEY PERFORMANCE PRODUCTS, INC.

REPLICATION OR TRANSMISSION OF THIS INFORMATION
WITHOUT WRITTEN AUTHORIZATION IS STRICTLY PROHIBITED.
ALL DIMENSIONS AND TOLERANCING CONFORM
TO ASME Y14.5-2009



THIRD ANGLE PROJECTION

Mandated Sensor and Harness Specifications



Cam Sync Signal Sensor, Sensor Kit, & Flying Magnet Target (Holley P/N 554-125, 554-126, & 554-127)

Parts List:

#	Components	554-125	554-126	554-127
1	Sensor w/ Nut	X		X
2	Flying Magnet Target		X	X
3	Split-Lock Washer (SS)		X	X
4	Connector	X		X
5	Pins	X		X
6	Seals	X		X
7	TPA Lock	X		X

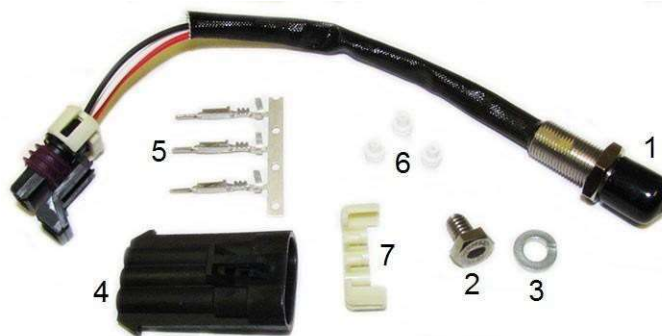

Cam Sync Signal Sensor (554-125):

P/N 554-125 is designed to generate a cam sync input signal when used in flying magnet cam trigger setups. This sensor is a Hall Effect sensor, meaning it outputs a square wave signal, which is ideal for use with most Electronic Fuel Injection Systems. This sensor is to only be used with a “flying magnet” target like Holley P/N 554-126. The internal Hall switch triggers from the South Pole of a magnet. It will not detect a ferrous metal target.

NOTE: If using a flying magnet target other than Holley P/N 554-126 with Holley EFI, correct magnetic pole orientation can be determined by waving the magnet past the sensor while performing an SL system log. Make sure the face of the magnet is being held parallel to the face of the sensor. If a trigger event registers, the magnet is oriented correctly; if not, flip the magnet and verify sensor triggering in that orientation. Install the magnet into the cam drive’s spider gear according to the orientation in which the trigger event occurred.

The sensor can operate from 8-20 volts. It is recommended to feed the sensor “clean” electrical power.

NOTE: This is not designed for systems requiring an inductive pickup as the sensor does not produce zero-crossings.

INSTALLATION:

1. Install the sensor into a mounting bracket containing M12 x 1mm threads. It is recommended to use a small crescent wrench on the sensor end & a 17 mm wrench on the nut.

NOTE: If creating a custom sensor bracket, an 11mm drill bit and M12 x 1mm tap will be required. These taps are readily available (McMaster-Carr P/N 26015A222).

2. With a feeler gauge, set the gap between the sensor and flying magnet target to .040”-.080” by backing the jam nut off and screwing the sensor in or out of the receiving bracket. The smaller the gap, the better. Lock the sensor’s

position by holding the sensor in place with a crescent wrench and tightening the jam nut. Do not tighten the jam nut beyond 23 ft.-lbs. or damage to the sensor threads may result.

NOTE: Ensure there will be no physical contact between the sensor and flying magnet target when the engine is operating.

3. Loose pins and seals are included and must be crimped onto an existing harness (Holley P/N 558-306). Use the proper tools to crimp Metripak 150 style pins (Delphi P/N: 12155975 - available thru Waytek, Inc. Item No.: 509). It is advised to use shielded wiring (with drain wire grounded at the ECU end) to connect to this sensor. The pins are inserted into the back of the connector. Install the TPA lock after the wires are inserted.

The following is the proper wiring for this sensor:

A – Red – 8V to 20V clean switched power. Pin B20 (“EST 12V Output”) on Holley EFI systems would be a good choice. Pin E at the “Ignition” connector of Holley P/N 558-306.

B – White – Sensor Output to ECU cam input signal (Pin A22 on Holley EFI). Pin B at the “Ignition” connector of Holley P/N 558-306.

C – Black – Sensor ground. Connect to a “clean” ECU ground such as pin A14 (“IPU Ground”) on Holley EFI systems. Pin G at the “Ignition” connector of Holley P/N 558-306.

4. If using Holley EFI, set the cam sensor “Type” to “Digital Rising” or “Digital Falling” in *Ignition Type* under Ignition Parameters. “Digital Falling” is recommended.

Flying Magnet Target (554-126):

P/N 554-126 was designed to provide a flying magnet trigger for cam sync signal sensors like Holley P/N 554-125 when used with dry timing belt cam drive systems (i.e.: Jesel KBD Series, CV Products XTS Series, Comp Cams Magnum Series, etc.).

INSTALLATION:

1. Ensure that the desired cam timing has been set and all upper cam drive pulley nuts have been tightened.
2. Determine the correct cam sync phasing for the specific application. If using Holley EFI, correct cam sync phasing and therefore, flying magnet target angular position can be determined using the following formula:

$$\text{Cam Sync Position} = \text{Crank Reference Angle} + (1080^\circ / \text{Number of Cylinders}) \pm 30^\circ$$

3. Once correct flying magnet crank angle position has been determined, make a reference mark on the face of the cam drive’s upper pulley or spider gear. If the ideal location falls on a lightening hole, simply place the mark at the center of the nearest web face before or after the hole.

NOTE: If using Holley EFI and exact angular position given by the calculation cannot be achieved due to the cam drive’s lightening hole locations, it is important to make sure the cam trigger event does not coincide with the crank pulse in 1-pulse per fire applications or coincide with the tooth directly before the gap on X-1 and X-2 trigger wheel applications (i.e.: 36-1, 60-2, etc.). Consider locating the flying magnet target on the next adjacent web face before or after the web face surface in question.

4. Locate and mark the correct radial mounting distance from the spider gear’s centerline. The radial centerline of the spider gear’s lightening-hole pattern (if applicable) is an ideal distance in most applications.



Step 3 & 4: Locate hole.

- Using a No.7 or 13/64" drill bit, drill a through hole at the intersection of the angular and radial reference marks. This may be done with a hand drill, on the engine, or a drill press or mill, off the engine. It is advised to use a center-punch to help locate the drill bit prior to drilling the cam gear.



Step 5: Drill hole.

NOTE: If drilling on the engine, care must be taken to keep from drilling into the underlying belt drive cover and block once the drill bit passes through the spider gear. A split-lock washer has been included for added flying target retention and optional off-engine drilling using a vertical mill. If it is desired to use the supplied washer, spot-face a flat on the surface of the spider gear over the 1/4" hole, using a 3/8" end mill. This will provide a flat surface on which the split-lock may fully seat. As an added precaution, medium strength thread adhesive should be used in accordance with the split lock washer. The engine may be operated immediately after installation if the split lock is being utilized.

- Using a 1/4"-20 starting tap, partially thread the previously drilled hole until the tip of the tap just begins to protrude the rear of the spider gear. This will ensure the flying magnet target cannot protrude the rear of the cam gear and make contact with the underlying cam cover studs.



Step 6: Tap hole.

NOTE: If the flying magnet screw happens to break through and protrudes beyond the rear face of the cam drive's spider gear, ensure that it does not make contact with the underlying cam cover studs. This can be done by ensuring that the engine can be rotated a full revolution (mind camshaft end-play) without interference. If contact is made, excess material should be cut or ground off the end of the screw. Care must be taken to prevent from putting too much heat into the part as doing so could weaken the encapsulated magnet or melt the surrounding epoxy.

7. Apply a liberal amount of permanent strength thread adhesive to the flying magnet target screw and thread it into the cam spider gear until it stops.

NOTE: Do not tighten the flying magnet screw beyond 70 in.-lbs. as doing so may result in stripped threads. It is recommended to allow the thread adhesive at least 24 hours to cure before operating the engine.



**HOLLEY TECHNICAL SUPPORT
1-270-781-9741**

© 2015 Holley Performance Products, Inc. All rights reserved.

**199R10799
Date: 6-4-15**



High Performance Coil-Near-Plug Smart Coil P/N 556-112

This coil is designed for use with Holley® HP and Dominator ECU's, as well other EFI systems that can drive "smart" ignition coils. Although it is designed for high powered race applications, it can be used on street driven vehicles as well.

Specifications:

Peak Voltage – 44,000 Volts

Peak Output – 102 mJ

Maximum Battery Voltage – 17.0 Volts

Mating Connector – Delphi P/N 12162825 "Pull to Seat"

Connector Pin – Delphi P/N 12124075 "Pull to Seat"

NOTE: The wire must be fed through the back of the housing, out the front, and then the pin crimped. Pull the wire back in to seat it.

Wiring:

The following refers to Holley® HP and Dominator EFI systems.

- Pin A – Coil Trigger. Connect to individual ECU EST Outputs. EST A should go to cylinder #1, EST B to cylinder #2, etc. Any gauge wire is acceptable. A 5V signal triggers this coil.
- Pin B – Coil Trigger Ground. These can be all tied together and go to Pin B14 (EST Ground Output). Any gauge wire is acceptable.
- Pin C – Ground to Cylinder Head. This ground **MUST** go to the cylinder head that the coil is discharging to. It is recommended to tie each cylinder bank together. Do **NOT** connect any other grounds to this point. This **MUST** be the only ground in this location. It is recommended to use an 18-20 gauge wire for each coil, and then tie them to a single 10-12 gauge wire.
- Pin D – Battery Ground. This high current ground should go to the battery or to a ground stud that is directly connected to the battery. Don't ground on sheet metal, etc. It is recommended to use 18-20 gauge wire, and then tie to a single 10-12 gauge wire.
- Pin E – High current switched +12V Power. Do **NOT** connect directly to the battery. It is recommended to install to a 40A relay source. Use 18-20 gauge wire for each coil, and then tie to a single 10-12 gauge wire.

Dwell Setting:

- For street cars below 1.5 HP per cubic inch, the dwell should be set to 4.0 msec.
- For cars that exceed 1.5 HP per cubic inch, the dwell should be set to 4.5 msec.
- For high boost, maximum effort drag race engines, the dwell can be set to 5.0 msec.

199R10662

Date: 6-5-13



High Performance Coil-Near-Plug Smart Coil P/N 556-112

This coil is designed for use with Holley® HP and Dominator ECU's, as well other EFI systems that can drive "smart" ignition coils. Although it is designed for high powered race applications, it can be used on street driven vehicles as well.

Specifications:

Peak Voltage – 44,000 Volts

Peak Output – 102 mJ

Maximum Battery Voltage – 17.0 Volts

Mating Connector – Delphi P/N 12162825 "Pull to Seat"

Connector Pin – Delphi P/N 12124075 "Pull to Seat"

NOTE: The wire must be fed through the back of the housing, out the front, and then the pin crimped. Pull the wire back in to seat it.

Wiring:

The following refers to Holley® HP and Dominator EFI systems.

- Pin A – Coil Trigger. Connect to individual ECU EST Outputs. EST A should go to cylinder #1, EST B to cylinder #2, etc. Any gauge wire is acceptable. A 5V signal triggers this coil.
- Pin B – Coil Trigger Ground. These can be all tied together and go to Pin B14 (EST Ground Output). Any gauge wire is acceptable.
- Pin C – Ground to Cylinder Head. This ground **MUST** go to the cylinder head that the coil is discharging to. It is recommended to tie each cylinder bank together. Do **NOT** connect any other grounds to this point. This **MUST** be the only ground in this location. It is recommended to use an 18-20 gauge wire for each coil, and then tie them to a single 10-12 gauge wire.
- Pin D – Battery Ground. This high current ground should go to the battery or to a ground stud that is directly connected to the battery. Don't ground on sheet metal, etc. It is recommended to use 18-20 gauge wire, and then tie to a single 10-12 gauge wire.
- Pin E – High current switched +12V Power. Do **NOT** connect directly to the battery. It is recommended to install to a 40A relay source. Use 18-20 gauge wire for each coil, and then tie to a single 10-12 gauge wire.

Dwell Setting:

- For street cars below 1.5 HP per cubic inch, the dwell should be set to 4.0 msec.
- For cars that exceed 1.5 HP per cubic inch, the dwell should be set to 4.5 msec.
- For high boost, maximum effort drag race engines, the dwell can be set to 5.0 msec.

199R10662

Date: 6-5-13



Holley® Universal Coil-On-Plug Ignition Harness P/N 558-307

This harness is designed to install Coil-On-Plug/Coil-Near-Plug (COP/CNP) coils on a Holley® EFI system that has a main wiring harness that does not contain COP trigger wires. The connectors included in this kit are specifically designed to plug into Holley® Smart Coil Ignition sub harness (P/N 558-312) or factory GM LSx coil harnesses which are not included. (GM P/N 12579355 - 2 required).

Pinout (for Odd/Even Banked V8 Engines, such as GM, Chrysler)

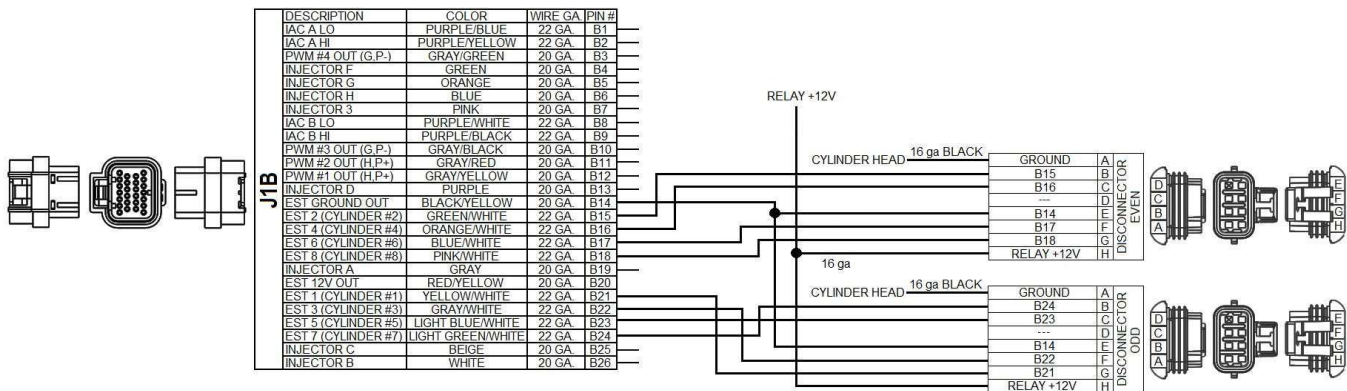

“DIS Connector Even”

Connect the terminated metripak end to the Holley® or GM coil harness. The other end is pre-terminated with ECU pins. If you would like to shorten this, extra pins are in the kit for both the ECU and metripak end (re-crimp whatever end you have proper crimpers for). Make sure crimps are done properly.

These Holley® coil harnesses can be installed “backwards” causing an engine misfire. Using the wiring information below, make sure the coil trigger wires for each cylinder are installed in their proper pin location at the J1B connector.

- A – Cylinder Head Ground. This wire should be as short as possible and be solidly attached to the cylinder head of the coils it is attached to. Ground this ONLY to the cylinder head, nowhere else.
- B – ECU J1 – B15 – Cylinder #2 Coil Trigger
- C – ECU J1 – B16 – Cylinder #4 Coil Trigger
- D – Blank
- E – ECU J1 – B14 – EST Signal Ground Out (Tie to DIS Connector Odd wire)
- F – ECU J1 – B17 – Cylinder #6 Coil Trigger
- G – ECU J1 – B18 – Cylinder #8 Coil Trigger
- H – Tie to red 14 gauge fused wire and connect to switched power that can properly supply 20 Amps, preferably a relay.

“DIS Connector Odd”

- A – Cylinder Head Ground. This wire should be as short as possible and be solidly attached to the cylinder head of the coils it is attached to. Ground this ONLY to the cylinder head, nowhere else.
- B – ECU J1 – B24 – Cylinder #7
- C – ECU J1 – B23 – Cylinder #5
- D – Blank
- E – ECU J1 – B14 – EST Signal Ground Out (Tie to DIS Connector Even wire)
- F – ECU J1 – B22 – Cylinder #3 Coil Trigger
- G – ECU J1 – B21 – Cylinder #1 Coil Trigger
- H – Tie to red 14 gauge fused wire and connect to switched power that can properly supply 20 Amps, preferably a relay.

Pinout (for Ford Engines or other V8 engines with 1-2-3-4 and 5-6-7-8 cylinder banks)

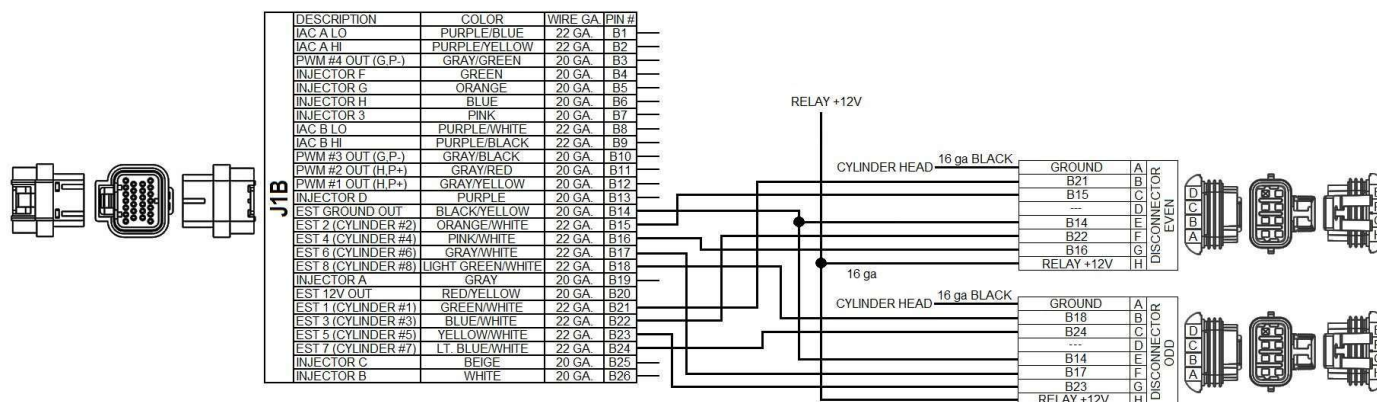

DIS Connector Even

- A – Cylinder Head Ground. This wire should be as short as possible and be solidly attached to the cylinder head of the coils it is attached to. Ground this ONLY to the cylinder head, nowhere else.
- B – ECU J1 – B21 – Cylinder #1 Coil Trigger
- C – ECU J1 – B15 – Cylinder #2 Coil Trigger
- D – Blank
- E – ECU J1 – B14 – EST Signal Ground Out (Tie to DIS Connector Odd wire)
- F – ECU J1 – B22 – Cylinder #3 Coil Trigger
- G – ECU J1 – B16 – Cylinder #4 Coil Trigger
- H – Tie to red 14 gauge fused wire and connect to switched power that can properly supply 20 Amps, preferably a relay.

DIS Connector Odd

- A – Cylinder Head Ground. This wire should be as short as possible and be solidly attached to the cylinder head of the coils it is attached to. Ground this ONLY to the cylinder head, nowhere else.
- B – ECU J1 – B18 – Cylinder #8 Coil Trigger
- C – ECU J1 – B24 – Cylinder #7 Coil Trigger
- D – Blank
- E – ECU J1 – B14 – EST Signal Ground Out (Tie to DIS Connector Even wire)
- F – ECU J1 – B17 – Cylinder #6 Coil Trigger
- G – ECU J1 – B23 – Cylinder #5 Coil Trigger
- H – Tie to red 14 gauge fused wire and connect to switched power that can properly supply 20 Amps, preferably a relay.

Software Setup

Assuming the engine application is not a factory GM 58x or 24x crankshaft reluctor engine, the Crank and Cam sensor types will have to be set up with an Ignition Type of "Custom". When running individual coils, you must have one of the following:

- "Missing Tooth" crank trigger (60-2 or 36-1) – If a cam sensor is not used, the coils will have to be fired in a waste fire mode (fire both on compression and exhaust strokes). If a cam sensor is present, the coils can be fired only on the compression stroke.
- "1 pulse/fire" – If the crank is a typical 4x trigger on a V8, there is no identification in the crank signal about which cylinder is number one. Hence, a 1 pulse/fire setup requires and depends on a cam sensor signal to identify cylinder number one.

See the "Crank and Cam Sensor" setup in the Holley EFI help instructions on properly setting up the positions of the crank and cam sensors.

The following is recommended Dwell times for various GM coil PN's:

Most coils can be set to a dwell time of 5.0 msec. Below are recommendations for various factory GM LS coils based upon Holley testing:

The following coil should be set to a maximum of 5.0 msec:

- 10457730

The following coil should be set to a maximum of 4.5 msec. A Value greater than this may cause the coil to fire prematurely resulting in overly advanced ignition timing:

- 19005218

The following coils should be set to a maximum of 3.5 msec:

- 12573190
- 12611424
- 12570616

NOTE: If using the Holley® Smart Coils (P/N 556-112), please refer to the instruction sheet provided with them for recommended dwell times.

**Holley® Performance Products
1801 Russellville Road
Bowling Green, KY 42101**

**1-270-781-9741
1-866-464-6553
www.holley.com**

© 2013 Holley Performance Products, Inc. All rights reserved.

**199R10515
Revision Date: 5-27-15**



Hall Effect, Ferrous Target Crankshaft Signal Sensor Holley P/N 554-124

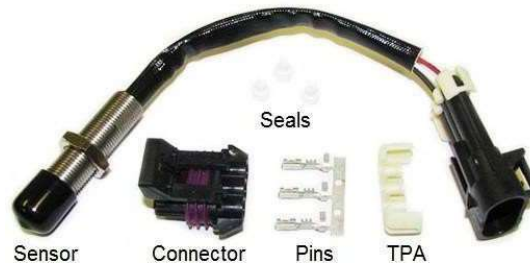

P/N 554-124 is designed to generate an RPM input signal when used in ferrous target crank trigger setups. This sensor is a Hall Effect sensor, meaning it outputs a square wave signal, which is ideal for use with most Electronic Fuel Injection Systems. This sensor is to only be used with trigger wheels with ferrous steel targets or teeth. It does not detect “flying magnets”.

The sensor can operate from 8-20 volts. It is recommended to feed the sensor “clean” electrical power.

NOTE: This is not designed for systems requiring an inductive pickup as the sensor does not produce zero-crossings.

INSTALLATION:

1. Install the sensor into a receiving bracket containing M12x1mm threads. It is recommended to use a small crescent wrench on the sensor end & a 17 mm wrench on the nut.

NOTE: If creating a custom sensor bracket an 11mm drill bit and M12x1 mm tap will be required. These taps are readily available. (McMaster-Carr P/N: 26015A222)

2. Using a feeler gauge, set the gap to .040”-.080” by backing the jam nut off and screwing the sensor in or out of the receiving bracket. The closer the better. Lock the sensor’s position with the jam nut. Do not tighten the jam nut beyond 23 ft.-lbs.

NOTE: Ensure there will be no physical contact between the sensor and trigger wheel when the engine is operating.

3. Loose pins and seals are included and must be crimped onto an existing harness like Holley P/N 558-306. Use the proper tools to crimp Metripak 150 style pins (Delphi P/N: 12155975-Available thru Waytek, Inc. Item No.: 509). It is advised to use shielded wiring (with drain wire grounded at the ECU end) to connect to this sensor. The pins are inserted into the back of the connector. Install the TPA lock after the wires are inserted.

The following is the proper wiring for this sensor:

- A – Red – 8V to 20V clean switched power. Pin B20 (“EST 12V Output”) on Holley EFI systems would be a good choice. Pin E at the “Ignition” connector of Holley P/N 558-306.
 - B – White – Sensor Output to ECU crank signal (Pin A30 on Holley EFI). Pin A at the “Ignition” connector of Holley P/N 558-306.
 - C – Black – Sensor ground. Connect to a “clean” ECU ground, such pin A14 (“IPU Ground”) on Holley EFI systems. Pin C at the “Ignition” connector of Holley P/N 558-306.
4. If using Holley EFI, set the crank sensor “Type” to “Digital Rising” or “Digital Falling” in *Ignition Type* under Ignition Parameters. “Digital Rising” is recommended.
 5. Make sure to check the ignition timing and alter the ignition reference angles or crank sensor position after the engine is started.

HOLLEY TECHNICAL SUPPORT: 1-270-781-9741

199R10800
Date: 6-4-15

© 2015 Holley Performance Products, Inc. All rights reserved.



Hall Effect Crankshaft Signal Sensor Holley P/N 554-118

P/N 554-118 is designed as a drop-in sensor replacement for flying magnet crank trigger setups using a 3/4-16" threaded magnetic sensor. This sensor is a hall effect sensor, meaning it outputs a square wave signal, which is ideal for use with most Electronic Fuel Injection Systems. This sensor is to only be used with a trigger wheel with "flying magnets". It does not detect a ferrous steel target.

The sensor can operate from 5-20 volts. It is recommended to feed the sensor "clean" electrical power.

NOTE: This is not designed for systems requiring an inductive pickup as the sensor does not produce zero-crossings.

INSTALLATION:

- 1) Remove existing sensor.
- 2) Install new sensor. Set the gap to .040"-.080". The closer the better. Ensure there can be no physical contact when the engine is operating.
- 3) Loose pins and seals are included and must be crimped onto existing harness. Use the proper tools to crimp metripak 150 style pins. It is advised to use shielded wiring (with drain wire grounded at the ECU end) to connect to this sensor. The pins are inserted into the back of the connector. Install the TPA lock after the wires are inserted.

The following is the proper wiring for this sensor:

- A- Red- 5V to 16V clean switched power. Pin B20 ("EST 12V Output") on Holley EFI systems would be a good choice.
 - B- White- Sensor Output to ECU crank signal (Pin A30 on Holley EFI).
 - C- Black- Sensor ground. Connect to a "clean" ECU ground, such pin A14 ("IPU Ground") on Holley EFI systems.
- 4) If using Holley EFI, set the crank sensor "Type" to "Digital Rising" or "Digital Falling". "Digital Falling" is recommended.
 - 5) Make sure you check the ignition timing and alter the ignition reference angles or crank sensor position after the engine is started.

**HOLLEY TECHNICAL SUPPORT
1-270-781-9741**

© 2012 Holley Performance Products, Inc. All rights reserved.

**199R10633
Date: 12-17-12**

NEW PRODUCT RELEASE



Holley EFI 36-1 Tooth Crank Trigger System for Big Block Chevy

AVAILABLE

PRODUCT DESCRIPTION



Holley's EFI Crank Trigger Kit is engineered to provide an accurate crank speed & position signal to Holley EFI systems in the most-demanding, high horsepower, racing applications. The position is measured every 10 degrees as opposed to every 45 degrees for a standard 4-Magnet, MSD "style" Crank trigger. It is designed for use on early model BBC Chevy applications using a standard ATI or Fluiddamper "style" balancer up to 7-1/4" in diameter.

*note- Will not work on balancers which do not have a center-hub extrusion (i.e.: Innovators West, etc.).

Features/Benefits:

- 8" diameter, 1/4" thick, billet steel, 36-1 tooth, crank wheel with Black Zinc Oxide finish for superior corrosion resistance & striking good looks.
- Crank wheel centers off of the balancer's hub, eliminating the need for a centering ring.
- All billet, 6061-T6 aluminum sensor mounting brackets with "bright-dipped" black anodized finish & Laser etched *Holley EFI* logo
- Custom 3-wire, ferrous-target, Hall-effect sensor with M12X1mm threads for finer gap adjustment
- All Grade 8 & Mil. Spec mounting hardware

If you have any questions about this or any Holley product application, please contact our tech service department at **270-781-9741**.

Setup Information

Part Number	SRP	MAP	Description	UPC	Length	Width	Height	Weight	UOM	Shipping ETA
556-113	\$422.95	\$379.95	36-1 Tooth Crank Trigger System for Big Block Chevy	090127720646	10	10	2	4.125	LB	10/1/2015



HP EFI SMART COIL SUB HARNESS P/N 558-312

Overview

PN 558-312 contains two terminated harnesses designed for use with Holley HP Smart Coils (PN 556-112) used on 8 cylinder engines. One end plugs directly into the Holley smart coil. The other end is terminated with a 7-pin metripak connector. This connector plugs into the Holley Universal Coil-On-Plug harness (PN 558-307, not included), Holley LSx main harnesses, or factory GM LSx harnesses. The layout is similar to factory GM LSx coil harnesses with some added length for coil mounting flexibility.

Installation

1. The coil connectors are marked based on engine type (GM/Others with 1-3-5-7 and 2-4-6-8 cylinder banks and Ford 1-2-3-4 and 5-6-7-8 cylinder banks). Install these as marked. The 7 pin metripak connectors (it has 8 cavities and 7 are populated) are labeled "GM EVEN" and "GM ODD". The "GM EVEN" plugs into the "DIS CONNECTOR EVEN" on the 558-307 harness or "IGNITION EVEN" on Holley LSx main harnesses. The "GM ODD" goes into corresponding "ODD" connectors on these harnesses.
2. For all applications, there is a 12 gauge BLACK ground wire that is separate in this harness. Connect this wire to a sturdy ground location that has a direct ground path to the battery. This connection should be independent of other grounds. Do **NOT** connect this ground wire to sheet metal, or other locations that may not have a solid ground path to the battery. If this wire needs to be extended, use 10-12 gauge wire and appropriate connectors.
3. Power and Ground Wiring – When running power and ground wires to these coils, bigger is always better. The RED power feed wire (pin H) and the BROWN ground wire (pin A) at the 7 pin metripak connector, are the two wires that must carry higher current loads. The proper connection of these wires can vary depending on your application. The different requirements for the most common installations are explained below.

3A. Stock and mild LSx applications with coil dwells set to 4.5 milliseconds and below:

Connect the ODD and EVEN connectors to the matching ODD and EVEN connector of the Holley EFI LSx main harness. Make sure the main harness coil grounds are connected to the back of the heads per the Holley EFI wiring instructions.

3B Applications using the 558-307 with coil dwells set to 4.5 milliseconds and below:

The 558-307 universal coil-on-plug harness was designed to provide power and ground to an OEM type LSx coil, and incorporates an 18 gauge RED power wire to the (H pins) of the ODD and EVEN connector. It is advised to cut the existing 18 gauge RED wire, leaving enough wire to connect and replace it with a 14 gauge RED wire as close as possible to the 7 pin metripak ODD and EVEN connector. This power supply should be wired through a relay, and not directly to the battery. **Tie the ground wires (pin A) directly to the cylinder heads and keep that wire as short as possible.**

3C. Applications that exceed 5.0 milliseconds of dwell and run at higher RPM (7500+) **OR** applications that run these coils in a waste-fire mode (no cam sync):

It is recommended to run 10-12 gauge wire power and ground directly to the 558-312 coil harnesses and bypass the metripak connector. Using an appropriate length of 10-12 gauge wire and the supplied splice connector and shrink tubing, replace the existing splice on the 4 coil power wires (RED), bypassing the 7 pin metripak connector. Perform the same operation on the existing splice on the 4 coil ground wires (BROWN). This splice/wiring should replicate what is used for the BLACK wire in these harnesses (**Fig. 1**). This kit contains 4 cavity plugs that can be installed if the power and ground wires are removed from the 7 pin metripak connector. Four crimp splices and heat shrink are included for this purpose.



Figure 1

Connector Pinouts

These are pre-terminated.

Coil Connectors

- **Pin A** – Coil Trigger – Connect to individual ECU EST Outputs. EST A should go to cylinder #1, EST B to cylinder #2, etc.
- **Pin B** – Coil Trigger Ground – These can be all tied together and go to Pin B14 (EST Ground Output).
- **Pin C** – Ground to Cylinder Head – This ground **MUST** go to the cylinder head that the coil is discharging to. It is recommended to tie each cylinder bank together. Do **NOT** connect any other grounds to this point. This **MUST** be the only ground in this location.
- **Pin D** – Battery Ground – This high current ground should go to the battery or to a ground stud that is directly connected to the battery. Do **NOT** ground on sheet metal, etc.
- **Pin E** – High current switched +12V Power – Do **NOT** connect directly to the battery. It is recommended to install to a 40A relay source to power all 8 coils.

Metripak Connector Pinouts

This information is contained with the 558-307 harness. If you do not have these instructions, it can be found on www.holley.com, under “Technical”, then “Instruction Sheets”, and type in 558-307.

Holley® Performance Products
1801 Russellville Road
Bowling Green, KY 42101

1-270-781-9741

1-866-464-6553

www.holley.com

© 2013 Holley Performance Products, Inc. All rights reserved.

199R10698

Date: 3-4-14



Connector J1A/B Input/Output Auxillary Harness P/N 558-400

This harness connects to the 8 pin Metripak Input/Output connector, located in most Holley EFI main harnesses (Terminator harness have a 3 pin I/O connector). The following indicates what ECU pin that the specific wires are connected to, and the type of input or output it can be configured as.

Wire Color	Type	Can be Configured As	ECU Pin	Connector Pin
White/Blue	Input	F 5 2 T H G	A12	A
White/Red	Input	F 5 2 T H G	A3	B
White/Black	Input	F 5 G	A13	C
White/Green	Input	F 5 G	A4	D
Grey/Yellow	Output	H P+	B12	E
Grey/Red	Output	H P+	B11	F
Grey/Black	Output	G P-	B10	G
Grey/Green	Output	G P-	B3	H

Inputs

- (F) **“Frequency”** - A digital input typically used for a speed input
- (5) **“0-5 Volt”** – Used for any 0-5 volt sensor input
- (2) **“0-20 Volt”** – Used for any 0-20 volt sensor input
- (T) **“Thermistor”** – Used for thermistor type sensor inputs (2 wire coolant/air temperature sensors)
- (H) **“High”** – Used for +12v switched inputs
- (G) **“Ground”** – Used for ground switched inputs
- (S) **“Speed”** – Used for inductive (AC signal) speed inputs

Outputs

- (H) **“High”** – Used for switched +12v (system voltage) outputs
- (G) **“Ground”** – Used for switched ground outputs
- (P+) **“PWM +”** – Used for high side (+12v) Pulse Width Modulated Outputs
- (P-) **“PWM – ”** – Used for ground Pulse Width Modulated Outputs

Technical Support: 1-866-464-6553

**199R10516
Date: 4-23-14**



P/N's 554-102, 554-103, 554-104, 554-108 and 554-133 thru 554-137 Pressure Transducers

- 554-102** – 0-100 PSI (plug and play for Holley Avenger, HP, and Dominator ECU Fuel and Oil Pressure inputs).
- 554-103** – 0-200 PSI (preconfigured for use in Holley HP and Dominator systems)
- 554-104** – 0-1600 PSI (preconfigured for use in Holley HP and Dominator systems)
- 554-108** – 5 Bar MAP sensor (0-520 kPa), (preconfigured for use in Holley HP and Dominator systems)
- 554-133** – 1 Bar MAP sensor (0-103 kPa)
- 554-134** – 3.5 Bar MAP sensor (0-345 kPa), (preconfigured for use in Holley HP and Dominator systems)
- 554-135** – 7 Bar MAP sensor (0-689 kPa)
- 554-136** – 0-500 PSI
- 554-137** – 0-3000 PSI

Each sensor has a linear voltage output range of .5 - 4.5 volts in the ranges listed above.

A pigtail is included with the sensor. The pinout for all of the sensors is as follows:

<u>Pin</u>	<u>Color</u>	<u>Description</u>
A	Black/White	Sensor Ground
B	Orange	Sensor +5v
C	Pink	Signal

Use a small amount of PTFE thread sealer on the threads when installing. Do not over-tighten sensor.

199R10560
Date: 7-23-15



P/N's 554-102, 554-103, 554-104, 554-108 and 554-133 thru 554-137 Pressure Transducers

- 554-102** – 0-100 PSI (plug and play for Holley Avenger, HP, and Dominator ECU Fuel and Oil Pressure inputs).
- 554-103** – 0-200 PSI (preconfigured for use in Holley HP and Dominator systems)
- 554-104** – 0-1600 PSI (preconfigured for use in Holley HP and Dominator systems)
- 554-108** – 5 Bar MAP sensor (0-520 kPa), (preconfigured for use in Holley HP and Dominator systems)
- 554-133** – 1 Bar MAP sensor (0-103 kPa)
- 554-134** – 3.5 Bar MAP sensor (0-345 kPa), (preconfigured for use in Holley HP and Dominator systems)
- 554-135** – 7 Bar MAP sensor (0-689 kPa)
- 554-136** – 0-500 PSI
- 554-137** – 0-3000 PSI

Each sensor has a linear voltage output range of .5 - 4.5 volts in the ranges listed above.

A pigtail is included with the sensor. The pinout for all of the sensors is as follows:

<u>Pin</u>	<u>Color</u>	<u>Description</u>
A	Black/White	Sensor Ground
B	Orange	Sensor +5v
C	Pink	Signal

Use a small amount of PTFE thread sealer on the threads when installing. Do not over-tighten sensor.

199R10560
Date: 7-23-15



INJECTOR BUNG INSTALLATION INSTRUCTIONS

WARNING! These instructions must be read and fully understood before beginning installation. Failure to follow these instructions may result in poor performance, vehicle damage, personal injury or death. If these instructions are not fully understood, installation should not be attempted.

INTRODUCTION:

Holley Performance Products cannot and will not be responsible for any alleged or actual engine or other damage, or other conditions resulting from misapplication of the products described herein. However, it is our intent to provide the best possible products for our customer; products that perform properly and satisfy your expectations. Should you need information or parts assistance, please contact our Technical Service Department at 1-270-781-9741, Monday through Friday, 8 a.m. to 5:00 p.m. Central Time; please have the part number of the product you purchased when you call.

WARNING! Installation of injector bungs requires machining your intake manifold. This procedure must be performed by a professional machine shop. All injector bungs must be drilled at the same angle to provide proper alignment of the fuel rails.

WARNING! For optimum performance, the injector must be pointed towards the center of the intake valve or in a position that will allow good fuel air distribution and allow for clearances. Before drilling the intake manifold for the injector bungs, three things need to be determined - one being, the angle of the drilled injector bung hole. Secondly, the height of the fuel rail assembly needs to be determined from the location of the injector bung installation location to check for interference. The injector bung can be raised and lowered in the machined hole providing a limited amount height clearances. The last thing to be determined is the securing of the fuel rails. Securing of the fuel rails need to be taken into consideration, because this could cause clearance problems in the final installation of your fuel injection system.

INSTALLATION:

1. Determine the angle at which the injector bung mounting hole will be machined.
2. Drill a 27/32 hole for the injector bung in each of the intake runners. This should only be performed by a machine shop with the proper equipment.

WARNING! Each drill hole must be drilled at the exact same angle or binding and misalignment will occur in the fuel injection system causing leaks and possible fire.

3. Install the fuel injectors into the fuel rail and install an injector bung onto each injector.
4. Fit and align the fuel rail assembly into the machined injector bung holes to check for clearance height and binding.
5. If the bungs are to be TIG welded, hold the fuel rail assembly in place and tack weld each bung into position. Remove the injectors before fully welding the bungs into position. To epoxy the injector bungs into position, use a quality fuel proof epoxy such as J.B. Weld. Apply a liberal amount of epoxy to each of the injector bungs and slide the fuel rail assembly into position and hold in position until epoxy sets up.

WARNING! DO NOT weld injector bungs in place with injector in the bung. The extreme heat from the welding will damage the injector.

WARNING! DO NOT allow the injector to come into contact with the epoxy. This could make the injector non-removable and possibly damage the injector.

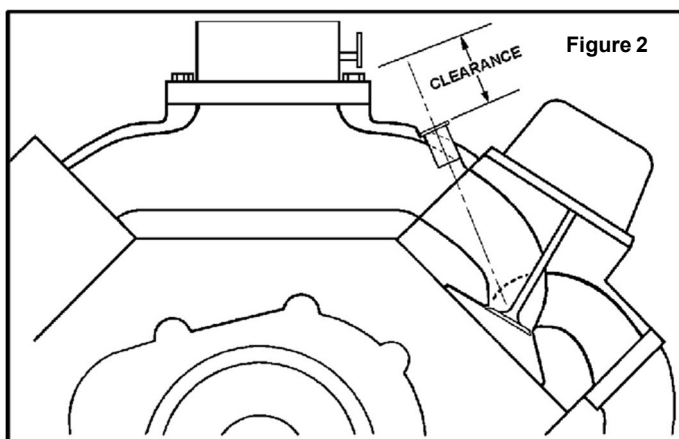
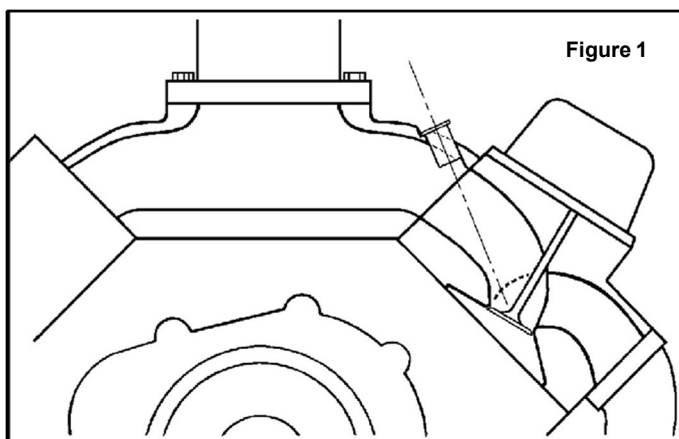

6. Remove the injectors from the injector bungs.
7. Remove the lower part of the injector bung sleeve, which extends into the intake runner with a hand grinder. This will prevent disruption of the air flow, however, DO NOT remove so much of the injector bung as to expose the O-ring of the injector which will cause a leak and possible fire.

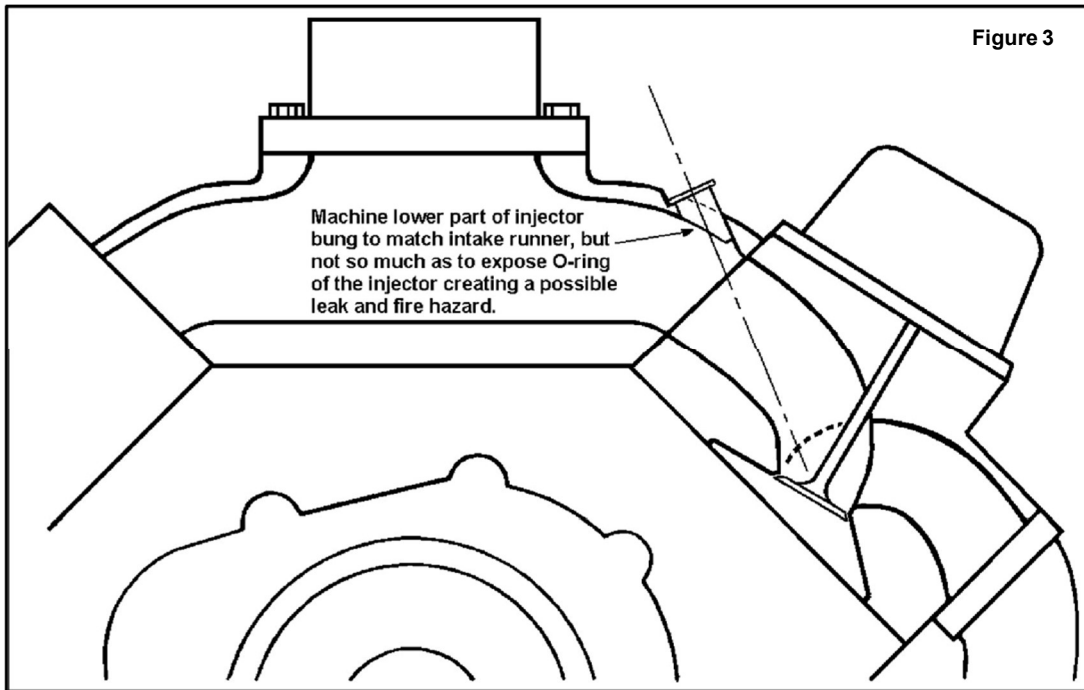

199R10072
Revision Date: 8-18-10

EFI CAN Communications



Holley EFI CAN Connector Kit P/N 558-412

Overview:

This kit is used to connect external CAN devices to either the J1A (HP and Dominator ECUs) or J3 (Dominator ECU only) connectors. The J3 ECU connector is supplied in this kit with the required CAN female pigtail. The J1A connector is not, but is included with every Holley main wiring harness. The female CAN pigtail is pre-installed in every J1A connector as well.

This kit is intended to be used to connect a Racepak Vnet/Holley EFI module to either the J1A or J3 connector. It can also be used to connect a Holley 5.7" Touch Screen LCD to the J3 connector.

Installation:

If using the J3 connector, install the J3 connector (1) into the ECU. Then, follow these instructions for either the J3 or J1A CAN connection:

1. Plug the male end of the short male/female harness (2) [this contains a CAN terminator] into the female connector at the ECU.
2. Plug the male end of the long harness (3) [not the end with the male and female connectors] into the first harness.
3. Plug the short male CAN terminator into the end of the harness (4).
4. Plug the CAN module (Racepak Vnet module, etc.) into the open male connector (5).

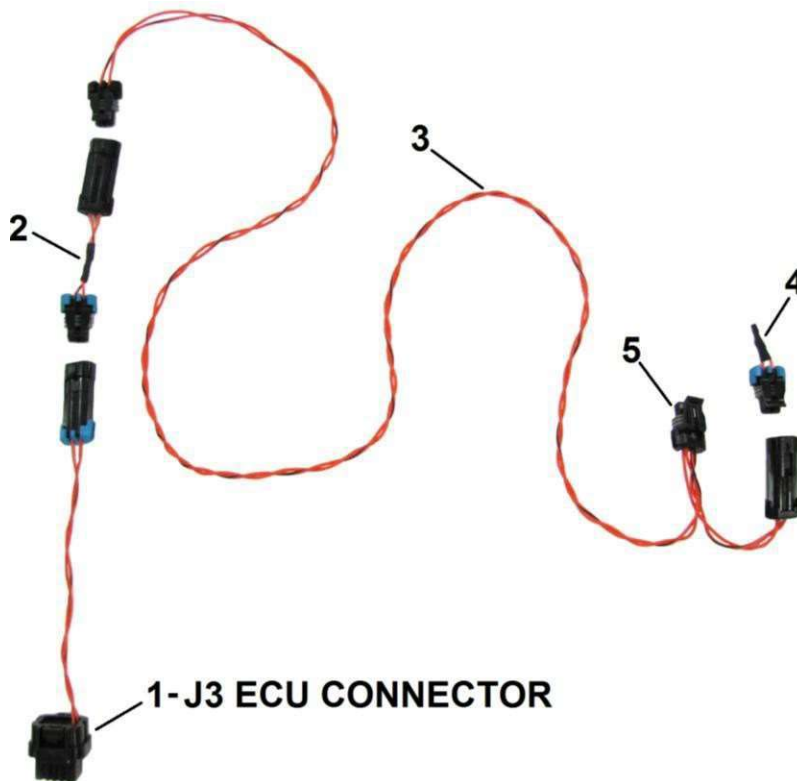

The wiring should be complete.

Software:

In order to use the Racepak Vnet module, or the J3 CAN output, you MUST upgrade to the "V2" software and firmware in your ECU. Any ECU can be upgraded. Go to the following web address (<http://www.holley.com/TechService/Library.asp>) and click on the "Fuel Injection" tab. Download the "V2 Update Instructions". Follow these and download other necessary files.

With the V2 software, the CAN outputs are configurable. To configure these, open the System ICF, select "Basic I/O", and select the "CAN Bus" tab. "CAN Bus 1" is the CAN output on the J1A connector. "CAN Bus 2" is the CAN output on the J3 connector. "Holley Standard" should be selected if using a Holley 5.7" touch screen LCD or other Holley CAN device. If using the Racepak Vnet module, select "Racepak".

At this point everything is complete.

Holley Tech Service: 1-270-781-9741 or 1-866-464-6553

**199R10654
Date: 4-9-13**

HEFI 3rd Party CAN Communications Protocol

Last updated Feb 11, 2015

General

This protocol is the public Holley HEFI Communications which can be used by third parties for display of ECU data. This was originally called the Racepak protocol.

CAN Packet Format

The CAN data rate is 1 Mbit/sec using extended identifier (CANID) format. Holley uses the ID as bit-wise structure:

Bits 31:29 – CAN flags (normally filtered out and read as 0)

Bits 28 – command bit (=1)

Bits 27:25 – Target ID (= 111, broadcast)

Bits 24:14 – Target Serial (used as a channel # index)

Bits 13:11 – source ID (= 010, hefi)

Bits 10:0 – source serial (the lower 11 bits of the serial # of the device as printed on the back of the ECU)

Example:

```
can_id = 0x1e02107b
command=1
targetid=7
targetserial=8
sourceid=2
sourceserial=123
```

The CAN data rate is 1 Mbit/sec using extended identifier (CANID) format. To decode data from any ECU you would mask out the lower 11 bits of the CANID (i.e., logical AND with 0xFFFFF800)

Monitor packets

Monitor data is continuously broadcast by the HEFI. The monitor packets contain an index in their CAN id and values in the data field. The data is sent at approximately 10mS intervals.

All monitor packets have a DLC of 8 bytes.

The 8 byte CAN data payload contains two values. Each set of 4 bytes (with the exception of RTC) is in a signed “*fixed 24.8*” format (essentially *fixed 24.8* = float *256)

The RTC is sent as an u32 showing milliseconds since power on, or if the RTC was set will it will be the current time of day.

For example,

- CANID 0x1E001000: 00 00 00 00 00 1d 4c 00
rpm data[4]=0x00, data[5]=0x1d, data[6]=0x4c, data[7]=00. Hex 0x001d4c00 =decimal
1920000/256 = 7500.0 RPM
- CANID 0x1E021000: 00 00 64 f8 00 00 82 80
barometric pressure = 0x000064f8 = decimal 25848/256 = 100.97
coolant temp = 0x00008280 = decimal 33408/256 = 130.5
- CANID 0x1E025000: 00 00 0a 40 00 00 0d cc
oil pressure = 0x00000a40 = decimal 2624/256 = 10.25
battery voltage = 0x00000dcc = decimal 3532/256 = 13.79

Note: the CAN ID in the following table has already been masked with 0xffff800 to remove the EFI serial number from the CAN ID. The actual CAN ID that is sent on the CAN bus is the id from the table below + ((EFI ID#) & 0x7ff). The EFI ID# is printed on the back of the unit in decimal.

Index	Description	Units	CAN data bytes	CAN ID (hex)
0	RTC (1/1000 sec since power on)	xx:xx:xx.xx time	[0..3]	1E001000
0	RPM	xx,xxx RPM	[4..7]	1E001000
1	Injector Pulsewidth	xx.x milliseconds	[0..3]	1E005000
1	Fuel Flow	x,xxx pounds/hour	[4..7]	1E005000
2	Closed Loop Status	On/Off	[0..3]	1E009000
2	Duty Cycle	xxx.x percent	[4..7]	1E009000
3	AFR Left	xx.x A/F	[0..3]	1E00D000
3	Closed Loop Compensation	xxx percent	[4..7]	1E00D000
4	Target AFR	xx.x A/F	[0..3]	1E011000
4	AFR Right	xx.x A/F	[4..7]	1E011000
5	Ignition Timing	xx.x degrees	[0..3]	1E015000
5	AFR Average	xx.x A/F	[4..7]	1E015000
6	Manifold Air Pressure (MAP)	xxx kPa	[0..3]	1E019000
6	Knock Retard	x degrees	[4..7]	1E019000
7	Manifold Air Temperature (MAT)	xxx F	[0..3]	1E01D000
7	Throttle Position Sensor (TPS)	xxx percent	[4..7]	1E01D000
8	Barometric Pressure	xxx.x kPa	[0..3]	1E021000
8	Coolant Temperature (CTS)	xxx F	[4..7]	1E021000
9	Oil Pressure	xxx psi	[0..3]	1E025000
9	Battery Voltage	xx.x volts	[4..7]	1E025000
10	Pedal Position	xxx percent	[0..3]	1E029000
10	Fuel Pressure	xxx psi	[4..7]	1E029000
11	Boost Gear	x	[0..3]	1E02D000
11	Main Rev Limit	on/off	[4..7]	1E02D000
12	Boost Speed	xxx mph	[0..3]	1E031000

Index	Description	Units	CAN data bytes	CAN ID (hex)
12	Boost Stage	x	[4..7]	1E031000
13	Target Boost	xx.x psi	[0..3]	1E035000
13	Boost Time	xxx.xx seconds	[4..7]	1E035000
14	Boost Solenoid Duty Cycle	xxx.x percent	[0..3]	1E039000
14	Boost	xx.x psi	[4..7]	1E039000
15	N20 Stage 1 %	xxx percent	[0..3]	1E03D000
15	Water Meth Injection %	xx.x percent	[4..7]	1E03D000
16	N20 Stage 3 %	xxx percent	[0..3]	1E041000
16	N20 Stage 2 %	xxx percent	[4..7]	1E041000
17	Gear	x	[0..3]	1E045000
17	N20 Stage 4 %	xxx percent	[4..7]	1E045000
18	Line Pressure	xxx percent	[0..3]	1E049000
18	Speed	xxx mph	[4..7]	1E049000
19	Input Shaft Speed	xxxx rpm	[0..3]	1E04D000
19	Line Temp	xxx F	[4..7]	1E04D000
20	Input #2	user defined, many options	[0..3]	1E051000
20	Input #1	user defined, many options	[4..7]	1E051000
21	Input #4	user defined, many options	[0..3]	1E055000
21	Input #3	user defined, many options	[4..7]	1E055000
22	Output #1	user defined, can be "on/off", x.xx msec, or xxx.x duty cycle	[0..3]	1E059000
22	Input #5	user defined, many options	[4..7]	1E059000
23	Output #3	user defined, can be "on/off", x.xx msec, or xxx.x duty cycle	[0..3]	1E05D000
23	Output #2	user defined, can be "on/off", x.xx msec, or xxx.x duty cycle	[4..7]	1E05D000
24	Output #5	user defined, can be "on/off", x.xx msec, or xxx.x duty cycle	[0..3]	1E061000
24	Output #4	user defined, can be "on/off", x.xx msec, or xxx.x duty cycle	[4..7]	1E061000

Holley 3rd party protocol decoder

Enter unit id/serial number (decimal)

with the exception of RTC, data is in signed fixed-point 24.8 format

to get RPM, use data payload bytes [0..3] of CAN message with identifier 0x1E001001 (assuming a unit id of 1).

to get battery voltage, use data payload bytes [4..7] of message with CAN identifier 0x1E025001 (for a unit id of 1).

Index	Description	Units	CAN data bytes	CAN ID (hex)
0	RTC (1/1000 sec since power on)	xx:xx:xx.xx time	[0..3]	1E001000
0	RPM	xx,xxx RPM	[4..7]	1E001000
1	Injector Pulsewidth	xx.x milliseconds	[0..3]	1E005000
1	Fuel Flow	x,xxx pounds/hour	[4..7]	1E005000
2	Closed Loop Status	On/Off	[0..3]	1E009000
2	Duty Cycle	xxx.x percent	[4..7]	1E009000
3	AFR Left	xx.x A/F	[0..3]	1E00D000
3	Closed Loop Compensation	xxx percent	[4..7]	1E00D000
4	Target AFR	xx.x A/F	[0..3]	1E011000
4	AFR Right	xx.x A/F	[4..7]	1E011000
5	Ignition Timing	xx.x degrees	[0..3]	1E015000
5	AFR Average	xx.x A/F	[4..7]	1E015000
6	Manifold Air Pressure (MAP)	xxx kPa	[0..3]	1E019000
6	Knock Retard	x degrees	[4..7]	1E019000
7	Manifold Air Temperature (MAT)	xxx F	[0..3]	1E01D000
7	Throttle Position Sensor (TPS)	xxx percent	[4..7]	1E01D000
8	Barometric Pressure	xxx.x kPa	[0..3]	1E021000
8	Coolant Temperature (CTS)	xxx F	[4..7]	1E021000
9	Oil Pressure	xxx psi	[0..3]	1E025000
9	Battery Voltage	xx.x volts	[4..7]	1E025000
10	Pedal Position	xxx percent	[0..3]	1E029000
10	Fuel Pressure	xxx psi	[4..7]	1E029000
11	Boost Gear	x	[0..3]	1E02D000
11	Main Rev Limit	on/off	[4..7]	1E02D000
12	Boost Speed	xxx mph	[0..3]	1E031000
12	Boost Stage	x	[4..7]	1E031000
13	Target Boost	xx.x psi	[0..3]	1E035000
13	Boost Time	xxx.xx seconds	[4..7]	1E035000
14	Boost Solenoid Duty Cycle	xxx.x percent	[0..3]	1E039000
14	Boost	xx.x psi	[4..7]	1E039000
15	N20 Stage 1 %	xxx percent	[0..3]	1E03D000
15	Water Meth Injection %	xx.x percent	[4..7]	1E03D000
16	N20 Stage 3 %	xxx percent	[0..3]	1E041000
16	N20 Stage 2 %	xxx percent	[4..7]	1E041000

17	Gear	x	[0..3]	1E045000
17	N20 Stage 4 %	xxx percent	[4..7]	1E045000
18	Line Pressure	xxx percent	[0..3]	1E049000
18	Speed	xxx mph	[4..7]	1E049000
19	Input Shaft Speed	xxxx rpm	[0..3]	1E04D000
19	Line Temp	xxx F	[4..7]	1E04D000
20	Input #2	user defined, many options	[0..3]	1E051000
20	Input #1	user defined, many options	[4..7]	1E051000
21	Input #4	user defined, many options	[0..3]	1E055000
21	Input #3	user defined, many options	[4..7]	1E055000
22	Output #1	user defined, can be "on/off", x.xx msec, or xxx.x duty cycle	[0..3]	1E059000
22	Input #5	user defined, many options	[4..7]	1E059000
23	Output #3	user defined, can be "on/off", x.xx msec, or xxx.x duty cycle	[0..3]	1E05D000
23	Output #2	user defined, can be "on/off", x.xx msec, or xxx.x duty cycle	[4..7]	1E05D000
24	Output #5	user defined, can be "on/off", x.xx msec, or xxx.x duty cycle	[0..3]	1E061000
24	Output #4	user defined, can be "on/off", x.xx msec, or xxx.x duty cycle	[4..7]	1E061000

Total Phase Data Center(tm) v6.61

(c) 2005- Inc.

www.totalphase.com

#

#

#

# Level	Ch	Index	m:s.ms.us	Len	Err	Bitrate	ID	Record
		0	0 0:00.000.000					Capture started
	0 A		1 0:00.000.000			1 MHz		<Bitrate Changed>
	0 A		2 0:00.000.000					<Listen-Only> / <Error Active>
	0 A		55 0:00.005.666	8 B		1 MHz	1e001088	Data Frame
	0 A		56 0:00.005.813	8 B		1 MHz	1e005088	Data Frame
	0 A		57 0:00.005.960	8 B		1 MHz	1e009088	Data Frame
	0 A		58 0:00.006.106	8 B		1 MHz	1e00d088	Data Frame
	0 A		59 0:00.006.250	8 B		1 MHz	1e011088	Data Frame
	0 A		60 0:00.006.394	8 B		1 MHz	1e015088	Data Frame
	0 A		61 0:00.006.541	8 B		1 MHz	1e019088	Data Frame
	0 A		62 0:00.006.689	8 B		1 MHz	1e01d088	Data Frame
	0 A		63 0:00.006.832	8 B		1 MHz	1e021088	Data Frame
	0 A		64 0:00.006.977	8 B		1 MHz	1e025088	Data Frame
	0 A		65 0:00.007.123	8 B		1 MHz	1e029088	Data Frame
	0 A		66 0:00.007.270	8 B		1 MHz	1e02d088	Data Frame
	0 A		67 0:00.007.416	8 B		1 MHz	1e031088	Data Frame
	0 A		68 0:00.007.563	8 B		1 MHz	1e035088	Data Frame
	0 A		69 0:00.007.712	8 B		1 MHz	1e039088	Data Frame
	0 A		70 0:00.007.861	8 B		1 MHz	1e03d088	Data Frame
	0 A		71 0:00.008.008	8 B		1 MHz	1e041088	Data Frame
	0 A		72 0:00.008.155	8 B		1 MHz	1e045088	Data Frame
	0 A		73 0:00.008.302	8 B		1 MHz	1e049088	Data Frame
	0 A		74 0:00.008.449	8 B		1 MHz	1e04d088	Data Frame
	0 A		75 0:00.008.595	8 B		1 MHz	1e051088	Data Frame
	0 A		76 0:00.008.741	8 B		1 MHz	1e055088	Data Frame
	0 A		77 0:00.008.888	8 B		1 MHz	1e059088	Data Frame
	0 A		78 0:00.009.035	8 B		1 MHz	1e05d088	Data Frame
	0 A		79 0:00.009.182	8 B		1 MHz	1e061088	Data Frame
	0 A		161 0:00.015.665	8 B		1 MHz	1e001088	Data Frame
	0 A		162 0:00.015.812	8 B		1 MHz	1e005088	Data Frame
	0 A		163 0:00.015.959	8 B		1 MHz	1e009088	Data Frame
	0 A		164 0:00.016.104	8 B		1 MHz	1e00d088	Data Frame
	0 A		165 0:00.016.249	8 B		1 MHz	1e011088	Data Frame
	0 A		166 0:00.016.393	8 B		1 MHz	1e015088	Data Frame
	0 A		167 0:00.016.540	8 B		1 MHz	1e019088	Data Frame
	0 A		168 0:00.016.687	8 B		1 MHz	1e01d088	Data Frame
	0 A		169 0:00.016.831	8 B		1 MHz	1e021088	Data Frame
	0 A		170 0:00.016.975	8 B		1 MHz	1e025088	Data Frame
	0 A		171 0:00.017.121	8 B		1 MHz	1e029088	Data Frame
	0 A		172 0:00.017.267	8 B		1 MHz	1e02d088	Data Frame

0 A	173	0:00.017.413	8 B	1 MHz	1e031088	Data Frame
0 A	174	0:00.017.561	8 B	1 MHz	1e035088	Data Frame
0 A	175	0:00.017.710	8 B	1 MHz	1e039088	Data Frame
0 A	176	0:00.017.858	8 B	1 MHz	1e03d088	Data Frame
0 A	177	0:00.018.005	8 B	1 MHz	1e041088	Data Frame
0 A	178	0:00.018.153	8 B	1 MHz	1e045088	Data Frame
0 A	179	0:00.018.300	8 B	1 MHz	1e049088	Data Frame
0 A	180	0:00.018.446	8 B	1 MHz	1e04d088	Data Frame
0 A	181	0:00.018.592	8 B	1 MHz	1e051088	Data Frame
0 A	182	0:00.018.739	8 B	1 MHz	1e055088	Data Frame
0 A	183	0:00.018.886	8 B	1 MHz	1e059088	Data Frame
0 A	184	0:00.019.033	8 B	1 MHz	1e05d088	Data Frame
0 A	185	0:00.019.179	8 B	1 MHz	1e061088	Data Frame

Five Star Fabrication Hood Components

Five Star Fabrication Hood Components

To order parts please contact Five Star Fabrication at 262-877-2171.

- **Filler Panels** – used to cover holes in the hood which accommodated the previously used air scoops. Filler Panels are currently available.
 - Camaro – P/N 64130-35818
 - Dart – P/N 64571-35818

- **Universal Cowl** – to be used on all body styles with the exception of the Camaro and Dart. Cowls will be available early 2016
 - P/N 64171-35818