



2026 NHRA Hot Rod Heritage Racing Series Rules Supplement

Initial Re-release: 2/19/2019 - Reformatted entire document and added all rule amendments since 2016. Made change to transmission section of Section 6: A/Fuel Eliminator.

2nd Release: 2/28/2019: Corrected error in Section 3: Nostalgia Eliminator, Engine: 1, Fuel – concerning the use of nitromethane. Corrected error in the table of contents.

3rd Release: 4/10/2019: Clarification to Section 4: 7.0 Pro, Electrical: 8 Ignition, Section 2: Gas Eliminator, Support Group:9, Tow Vehicles: corrected error.

4th Release: 1/21/2020: Deleted 2005 helmets from Hot Rod Eliminator, Permit stripe taker (within 40 inch rule) in Nostalgia Funny Car, Made clerical correction in Nostalgia Funny Car Designation, Increased size of fuel pump in A Fuel for blown alcohol

5th Release: 9/1/2020: Added Snell M2020 and SA2020 helmets

6th Release: 9/24/2020: Added SFI 31.1/2020 and 41.1/2020 helmets, Added Earp Machinery fuel pumps NOSFC and NOSTF, Added reference to SFI Specifications, NHRA Quick Reference Chart and Handy Charts and Formulas in NHRA Rulebook and Amendments

7th Release: 3/5/2021: Permitted fuel management for supercharged alcohol altered combinations weighing a minimum of 2,100 pounds and having a 3-speed transmission in A Fuel. Added mandatory pan pressure shutoff system to Nostalgia Top Fuel, Beginning 2022 added bright colored pilot chutes mandatory in A Fuel, Nostalgia Funny Car and Nostalgia Dragster, General Regulations – Pressure sensors and parachute nets permitted on wheelie bars but no other devices, General Regulations – Fire bottle pin reminder.

2026
Hot Rod Heritage Racing Series Rules Supplement

8th Release: 6/4/2021: Added FIA 8860-2010. FIA 8860-2015 and FIA 8860-2018 Helmets

9th Release: 9/22/2021: Beginning January 1, 2022, added helmet removal system, additional Protective Clothing requirements for A/Fuel Eliminator, Nostalgia Funny Car and Nostalgia Top Fuel (edits shown in yellow highlights)

10th Release: 2/2/2022: Changed year in title from 2021 to 2022

11th Release: 3/14/2022: Added Docol R8 everywhere chromoly is used

12th Release: 1/20/2023: Nostalgia A/Fuel, TF, and FC fuel pump GPM and testing procedures. Nostalgia FC pan pressure switch mandatory. Nostalgia TF and FC one-piece fire suits. Nostalgia A/Fuel, TF, and FC SFI 15.3 drive wheels mandatory. Nostalgia TF and FC clutch exhaust filter mandatory. Nostalgia Eliminator, Dragster, front overhang not to exceed 30 inches. Snell M2010, SA2010, SFI 2010 helmets expired

13th Release: 2/14/2023: Nostalgia A/Fuel one piece fire suit

14th Release: 1/23/2024: Additional body years accepted in Hot Rod Eliminator, Gas Eliminator, and Nostalgia Funny Car. Additional fuel pump accepted for Nostalgia Funny Car and Top Fuel.

15th Release: 1/30/2024: Hot Rod and Gas Eliminator, NHRA license required to earn series points. Nostalgia Funny Car and Top Fuel, updated NHRA accepted fuel pumps.

16th Release: 3/01/2024: Additional body years accepted in Nostalgia Eliminator and 7.0 Eliminator. Vendor change for fuel pump certification for Nostalgia Funny Car and Top Fuel. Beginning January, 1, 2025, Head and Neck Restraint required for all vehicles over 150 mph or 7.49 (4.49) or quicker.

17th Release: 3/28/2024: Hot Rod Eliminator updates to the following sections: Oil Retention Device, Supercharger (Roots only), Flywheel, Brakes, Chassis, Protective Clothing, Body, and Window Net.

18th Release: 12/17/2024: Nostalgia Funny Car and Top Fuel, 4-inch, 44A Magneto permitted. Nostalgia Funny Car and Top Fuel parachute tethers mandatory. Updated FIA helmet 8860-2015 to 8859-2015. Added FIA helmet 8859-2024.

19th Release: 07/31/2025: A/Fuel Eliminator ruleset updated. Nostalgia Top Fuel, crank triggers permitted.

20th Release: 11/07/2025: Added Snell M2025 and SA2025 helmets

21st Release: 02/03/2026: Nostalgia Funny Car and Top Fuel, updated manufacturers and part numbers of accepted fuel pumps, updated fuel pump certification vendor.

22nd Release: 02/06/2026: A/Fuel renamed Pro Comp

2026
Hot Rod Heritage Racing Series Rules Supplement

TABLE OF CONTENTS

| | |
|--|-----------|
| 2026 NHRA HOT ROD HERITAGE RACING SERIES RULES SUPPLEMENT | 1 |
| NHRA HOT ROD HERITAGE RACING SERIES RULES SUPPLEMENT | 6 |
| SECTION 1: HOT ROD ELIMINATOR | 9 |
| REQUIREMENTS & SPECIFICATIONS | 9 |
| ENGINE: 1..... | 9 |
| DRIVETRAIN: 2 | 10 |
| BRAKES AND SUSPENSION: 3..... | 11 |
| FRAME: 4..... | 11 |
| TIRES & WHEELS: 5..... | 12 |
| INTERIOR: 6 | 12 |
| BODY: 7 | 12 |
| ELECTRICAL: 8..... | 13 |
| SUPPORT GROUP: 9..... | 13 |
| DRIVER: 10..... | 13 |
| SECTION 2: GAS ELIMINATOR | 15 |
| REQUIREMENTS & SPECIFICATIONS | 15 |
| ENGINE: 1..... | 15 |
| DRIVETRAIN: 2 | 16 |
| BRAKES AND SUSPENSION: 3..... | 17 |
| FRAME: 4..... | 17 |
| TIRES & WHEELS: 5..... | 18 |
| INTERIOR: 6 | 18 |
| BODY: 7 | 18 |
| ELECTRICAL: 8..... | 19 |
| SUPPORT GROUP: 9..... | 20 |
| DRIVER: 10..... | 20 |
| SECTION 3: NOSTALGIA ELIMINATOR..... | 21 |
| REQUIREMENTS & SPECIFICATIONS | 22 |
| ENGINE: 1..... | 22 |
| DRIVETRAIN: 2 | 23 |
| BRAKES AND SUSPENSION: 3..... | 23 |
| FRAME: 4..... | 23 |
| TIRES & WHEELS: 5..... | 24 |
| INTERIOR: 6 | 24 |
| BODY: 7 | 24 |
| ELECTRICAL: 8..... | 25 |
| SUPPORT GROUP: 9..... | 25 |
| DRIVER: 10..... | 26 |
| SECTION 4: 7.0 ELIMINATOR..... | 27 |
| REQUIREMENTS & SPECIFICATIONS | 27 |
| ENGINE: 1..... | 27 |
| DRIVETRAIN: 2 | 28 |
| BRAKES AND SUSPENSION: 3..... | 29 |

2026
Hot Rod Heritage Racing Series Rules Supplement

| | |
|--|-----------|
| FRAME: 4..... | 29 |
| TIRES & WHEELS: 5..... | 30 |
| INTERIOR: 6..... | 30 |
| BODY: 7..... | 30 |
| ELECTRICAL: 8..... | 30 |
| SUPPORT GROUP: 9..... | 30 |
| DRIVER: 10..... | 31 |
| SECTION 5: JUNIOR FUEL ELIMINATOR..... | 31 |
| REQUIREMENTS & SPECIFICATIONS..... | 32 |
| ENGINE: 1..... | 32 |
| DRIVETRAIN: 2..... | 33 |
| BRAKES AND SUSPENSION: 3..... | 33 |
| FRAME: 4..... | 34 |
| TIRES & WHEELS: 5..... | 34 |
| INTERIOR: 6..... | 34 |
| BODY: 7..... | 34 |
| ELECTRICAL: 8..... | 35 |
| SUPPORT GROUP: 9..... | 35 |
| DRIVER: 10..... | 35 |
| SECTION 6: PRO COMP (FORMALLY A/FUEL ELIMINATOR)..... | 36 |
| REQUIREMENTS & SPECIFICATIONS..... | 36 |
| ENGINE: 1..... | 36 |
| DRIVETRAIN: 2..... | 39 |
| BRAKES AND SUSPENSION: 3..... | 39 |
| FRAME: 4..... | 40 |
| TIRES & WHEELS: 5..... | 40 |
| INTERIOR: 6..... | 42 |
| BODY: 7..... | 42 |
| ELECTRICAL: 8..... | 42 |
| SUPPORT GROUP: 9..... | 43 |
| DRIVER: 10..... | 43 |
| SECTION 7: NOSTALGIA FUNNY CAR..... | 44 |
| REQUIREMENTS & SPECIFICATIONS..... | 44 |
| ENGINE: 1..... | 44 |
| DRIVETRAIN: 2..... | 47 |
| BRAKES AND SUSPENSION: 3..... | 47 |
| FRAME: 4..... | 48 |
| TIRES & WHEELS: 5..... | 49 |
| INTERIOR: 6..... | 49 |
| BODY: 7..... | 49 |
| ELECTRICAL: 8..... | 50 |
| SUPPORT GROUP: 9..... | 51 |
| DRIVER: 10..... | 51 |
| SECTION 8: NOSTALGIA TOP FUEL..... | 52 |
| REQUIREMENTS & SPECIFICATIONS..... | 53 |
| ENGINE: 1..... | 53 |
| DRIVETRAIN: 2..... | 55 |
| BRAKES AND SUSPENSION: 3..... | 56 |
| FRAME: 4..... | 56 |

2026
Hot Rod Heritage Racing Series Rules Supplement

| | |
|---|-----------|
| TIRES & WHEELS: 5..... | 57 |
| INTERIOR: 6 | 57 |
| BODY: 7 | 58 |
| ELECTRICAL: 8..... | 58 |
| SUPPORT GROUP: 9..... | 59 |
| DRIVER: 10..... | 59 |
| | |
| SECTION 9: AUTHENTIC HISTORIC VEHICLE..... | 60 |
| | |
| SECTION 10: CACKLEFEST VEHICLE | 62 |
| REQUIREMENTS & SPECIFICATIONS..... | 62 |
| GENERAL..... | 62 |
| ENGINE: 1..... | 62 |
| DRIVETRAIN: 2 | 63 |
| SUPPORT GROUP: 9..... | 63 |
| DRIVER: 10..... | 64 |
| | |
| SECTION 11: GENERAL REGULATIONS..... | 64 |
| REQUIREMENTS & SPECIFICATIONS..... | 65 |
| ENGINE: 1..... | 65 |
| DRIVETRAIN: 2 | 70 |
| BRAKES AND SUSPENSION: 3..... | 76 |
| FRAME: 4..... | 78 |
| TIRES & WHEELS: 5..... | 82 |
| INTERIOR: 6 | 83 |
| BODY: 7 | 84 |
| ELECTRICAL: 8..... | 86 |
| SUPPORT GROUP: 9..... | 88 |
| DRIVER: 10..... | 92 |
| GENERAL: 11..... | 98 |
| SFI SPECIFICATIONS..... | 98 |
| NHRA E.T. QUICK REFERENCE CHART | 98 |
| HANDY CHARTS AND FORMULAS | 98 |

NHRA HOT ROD HERITAGE RACING SERIES RULES SUPPLEMENT

Drag racing is a dangerous sport. There is no such thing as a guaranteed safe drag race. Drag racing always carries with it the risk of serious injury or death in any number of ways. This risk will always exist no matter how much everyone connected with drag racing tries to make our sport safer. Although NHRA works to promote and enhance the safety of the sport, there are no guarantees that such safety measures will guarantee or ensure safety. The participant always has the responsibility for the participant's own safety, and by participating in drag racing, the participant accepts all risks of injury, whether due to negligence, vehicle failure, or otherwise. If at any time a participant does not accept these risks, the participant agrees not to participate in drag racing.

NHRA has developed this Hot Rod Heritage Racing Series Rules Supplement program, which incorporates technical and competition guidelines, to accommodate those categories in an accepted Alternate Sanctioning Organization and not clearly defined by the NHRA Rulebook.

The rules and regulations set forth in this Supplement apply specifically to such vehicles and drivers and to performance and conduct at any NHRA event or member track.

These rules and regulations are excerpts from or supplements to the NHRA Rulebook, and participants and track officials should consult the current NHRA Rulebook for additional applicable information.

CATEGORIES OR OTHER EXHIBITION NOSTALGIA CLASSES (FOR EXAMPLE, NOSTALGIA SUPER STOCK) THAT ARE NOT IN THIS HOT ROD HERITAGE RACING SERIES RULES SUPPLEMENT WILL BE GOVERNED BY SECTION 4A (SUPER PRO, PRO, SPORTSMAN) AND SECTION 4B (ADVANCED E.T.) OF THE NHRA RULEBOOK.

The NHRA Hot Rod Heritage Racing Series Rules Supplement provides guidelines and minimum standards for the construction and operation of vehicles used in NHRA Championship Drag Racing and at member-track events. Additional safety equipment or safety-enhancing equipment is always permitted, and the levels of safety equipment stated in this Rulebook are minimum prescribed levels for a particular type of competition and do not prohibit the individual racer from using additional safety equipment. Participants are encouraged to investigate the utility of additional safety devices for their type of competition. In disputed cases, whether an item of equipment is safety-enhancing or performance-enhancing will be determined by NHRA in NHRA's sole and absolute discretion.

Regarding performance equipment, it is the general rule that unless optional performance equipment or performance-related modification is specifically permitted by this Supplement, it is prohibited. All model, engine, or equipment changes or

modifications not specifically addressed in this Supplement must be submitted in writing to NHRA for consideration prior to competition. Approval will be granted or denied in NHRA's sole and absolute discretion. The applicant will be notified of approval or rejection in writing from NHRA headquarters in San Dimas, CA. Unauthorized cars, parts, and/or equipment will not be considered approved by reason of having passed through technical inspection at any time or any number of times. Moreover, having passed through technical inspection at any time or any number of times is not a defense to a violation found on further inspection.

It is essential for every participant to understand this fundamental rule of drag racing: Prime responsibility for the safe condition and operation of a vehicle in competition rests with the vehicle owner, driver, and crewmembers. The track operator's main concern is to provide a place to conduct events. NHRA produces guidelines based on experience and circulates information to help perpetuate the sport. Close observance of the standards set forth in this Supplement is required for all participants, including owners, drivers, and crewmembers. However, drag racing is dangerous. Therefore, no express or implied warranty of safety is created from publication of or compliance with NHRA rules, nor does compliance with NHRA rules guarantee against injury or death to participants, spectators, or others.

It is the responsibility of the participant to be familiar with the contents of this Supplement and to comply with its requirements. Do not leave it up to track officials to catch all potential rule compliance problems. That responsibility rests first and foremost with YOU — the participant. Additional safety equipment or safety-enhancing equipment is always permitted and the levels of safety equipment stated in this Supplement are minimum prescribed levels for a particular type of competition and do not prohibit the individual racer from using additional safety equipment. Participants are encouraged to investigate the utility of additional safety devices for your type of competition. In disputed cases, whether an item of equipment is safety-enhancing or performance enhancing will be determined by NHRA in NHRA's sole and absolute discretion.

On the other hand, as to performance equipment, it is the general rule that unless optional performance equipment or performance-related modification is specifically permitted by this Supplement, it is prohibited. All model, engine, or equipment changes or modifications not specifically addressed in this Supplement must be submitted in writing to NHRA for consideration prior to competition. Approval will be granted or denied in NHRA's sole and absolute discretion. The applicant will be notified of approval or rejection in writing from NHRA headquarters in San Dimas, CA.

Throughout this Supplement, a number of references are made for particular products to meet certain specifications (i.e., SFI Specs, Snell, DOT, etc.). It is important to realize that these products are manufactured to meet certain specifications, and upon completion, the manufacturer labels the product as meeting that spec. Therefore, except as outlined under SFI requirements, any change to the product voids that certification. Under no circumstances may any

2026
Hot Rod Heritage Racing Series Rules Supplement

certified product be modified, altered, or in any way vary from the “as manufactured” condition. Such a practice is in violation of the SFI, Snell, DOT, etc. program, voids such certification and therefore will not be accepted by NHRA.

NOTICE: It is the responsibility of the participant, not NHRA or any track, to ensure that all safety equipment is approved and is correctly installed, worn, maintained and used.

Remember, it is your responsibility to follow the standards in this Supplement that pertain to your vehicle.

Each and every participant is bound by this Supplement and is held responsible for knowledge of and compliance with this Supplement. Ignorance or misunderstanding of a rule does not excuse non-compliance. Participants’ knowledge of and compliance with this Supplement contributes to the safety of the sport and is required. By participating in the sport, every participant affirms that he or she has read, understands and agrees to be bound by all NHRA rules and regulations, including those contained in the NHRA Rulebook, including amendments.

SECTION 1: HOT ROD ELIMINATOR

DESIGNATION

H/R, preceded by number.

Reserved for 1989 and older left-hand-steer full-bodied vehicles. Front-engine dragster, altereds, or any other open-cockpit car prohibited.

Competition structure will be conducted in an E.T. dial-your-own format, with dial-in limited from 8.50 minimum to 13.99 seconds maximum. Class uses a five-tenths full Tree start.

REQUIREMENTS & SPECIFICATIONS

ENGINE: 1

ENGINE

One internal-combustion automotive-type engine permitted. Harmonic balancer meeting SFI Spec 18.1 mandatory in any car running 10.99 (6.99*) or quicker. See General Regulations 1:1.

EXHAUST SYSTEM

Competition exhaust permitted. Exhaust must be directed out of car to rear, away from driver and fuel tank. See General Regulations 1:3.

FUEL

Racing gasoline, gasoline, alcohol, gasohol, diesel, ethanol, natural gas, and propane permitted. Nitromethane prohibited.

FUEL SYSTEM

All fuel-tank filler necks located inside trunk must have filler neck vented to outside of body. Vented caps prohibited. All batteries, fuel lines, fuel pumps, or filler necks located inside trunk require complete bulkhead of at least .024-inch steel or .032-inch aluminum to isolate driver compartment from trunk. Fuel lines must be located outside driver compartment. Fuel tanks must be within confines of the body. No pressurized fuel tanks allowed. See General Regulations 1:5.

LIQUID OVERFLOW

Catch can mandatory for coolant overflow; one-pint (16-ounce) minimum capacity. See General Regulations 1:7.

OIL RETENTION DEVICE

All vehicles permitted to utilize an NHRA-accepted lower engine oil-retention device. See General Regulations 1:8.

NITROUS OXIDE

Nitrous oxide prohibited.

THROTTLE

Positive throttle return required. Each car must have a foot throttle incorporating a positive-acting return spring attached directly to the carburetor/injector throttle arm.

2026
Hot Rod Heritage Racing Series Rules Supplement

Throttle control must be manually operated by driver's foot, incorporating a positive-action return system. See General Regulations 1:12.

SUPERCHARGER

Roots-type supercharger only. Permitted on gasoline-, racing-gasoline-, and alcohol-burning cars. Supercharger restraint system meeting SFI Spec 14.1 mandatory when alcohol is used as fuel. Manifold burst panel mandatory. Supercharger restraint straps must be covered with a fire-resistant material. The blower restraint straps and fuel lines must be installed such that when the restraint straps are fully extended no load is placed on any of the fuel lines. Supercharger belt guard that protects all fuel, oil, and water lines required. No composite materials in injector hat and/or scoop allowed. Composite materials include but are not limited to carbon fiber, Kevlar, and weave-graphite fiber. Hat/scoop must be nostalgic in appearance. Internal modifications permitted. Scoops limited to 12.5 inches above throttle body. Air intake limited to 65 square inches. See General Regulations 1:10.

VALVE COVERS

Cast or fabricated metal valve covers, using all attachment bolt holes, mandatory on supercharged, methanol-burning cars.

DRIVETRAIN: 2

CLUTCH, FLYWHEEL, FLYWHEEL SHIELD

Flywheel and clutch meeting SFI Spec 1.1 or 1.2 (two-disc maximum) mandatory on any car running 11.49 (7.35*) or quicker. Flywheel shield meeting SFI Spec 6.1, 6.2, or 6.3 mandatory on all cars running 11.49 (7.35*) or quicker. See General Regulations 2:3, 2:5, 2:6, 2:10.

DRIVELINE

Driveshaft loop required on all cars, except vehicles running 11.49 (7.35*) seconds or slower equipped with street tires. In all cars where the driveline passes any part of the driver's body, the driveshaft must be completely enclosed in a minimum 1/8-inch-thick steel plate securely mounted to frame structure, bellhousing, and/or rear-end center section. See General Regulations 2:4.

REAR END

Aftermarket axles and axle-retention device mandatory on any car running 10.99 (6.99*) or quicker or any car with locked differential. See General Regulations 2:11.

TRANSMISSION, AFTERMARKET PLANETARY

Transmission shield meeting SFI Spec 4.1 mandatory on any supercharged vehicle or any vehicle burning methanol, running 9.99 seconds or quicker, and equipped with aftermarket planetary transmission. See General Regulations 2:12, 2:13.

TRANSMISSION, AUTOMATIC

Spring-loaded, positive reverse lockout device and functional neutral safety switch mandatory. Transmission shield meeting SFI Spec 4.1 mandatory on any car running 10.99 (6.99*) or quicker or any car exceeding 135 mph. Automatic transmission flexplate meeting SFI Spec 29.1 and flexplate shield meeting SFI Spec 30.1 mandatory on cars running 9.99 (6.39*) or quicker or any car exceeding 135 mph. See General Regulations 2:12, 2:14.

BRAKES AND SUSPENSION: 3

BRAKES

Minimum two rear-wheel (one caliper per wheel) hydraulic brakes mandatory. See General Regulations 3:1.

STEERING

See General Regulations 3:3, 4:1.

SUSPENSION, STOCK-BODIED CARS

Full automotive-type suspension mandatory. Minimum one operating hydraulic shock absorber per wheel. Lightening of stock components prohibited. Rigid-mounted suspensions prohibited. See General Regulations 3:2, 3:4, 3:5.

WHEELIE BARS

Permitted. Wheels must be nonmetallic. See General Regulations 3:6.

FRAME: 4

BALLAST

Permitted. See General Regulations 4:2.

GROUND CLEARANCE

Minimum 3 inches from front of car to 12 inches behind centerline of front axle, 2 inches for remainder of car, except oil pan and headers. See General Regulations 4:5.

PARACHUTE

Mandatory on any car that runs 150 mph or faster. See General Regulations 4:8.

ROLL BAR

Roll bar mandatory in all cars running 11.00 (7.00*) to 11.49 (7.35*), in convertibles running 11.00 (7.00*) to 13.49 (8.25*). Permitted in all cars. See General Regulations 4:10, 10:6.

ROLL CAGE

Roll cage mandatory in cars running 10.99 (6.99*) or quicker or any car exceeding 135 mph. In full-bodied cars with unaltered firewall, floor, and body (from firewall rearward, wheel tubs permitted), running between 10.00 (6.40*) and 10.99 (6.99*), roll bar permitted in place of roll cage. In convertibles running 10.99 (6.99*) or quicker or exceeding 135 mph, roll cage mandatory. Cars running 9.99 (6.39*) and quicker must have chassis inspected every three years by NHRA and have a serialized sticker affixed to cage before participation. Plating of chassis prohibited for all cars manufactured after Jan. 1, 2003. All others must conform to specs for body style used, as listed in General Regulations 4:11, 10:6.

ROLL-CAGE PADDING

Roll-cage padding meeting SFI Spec 45.1 mandatory on any vehicle running 9.99 (*6.39) and quicker. Padding must be used anywhere driver's helmet may come in contact with roll-cage components. See General Regulations 4:11, 10:6.

WHEELBASE

Minimum 90 inches, unless car has original engine. Maximum wheelbase variation from left to right: 1 inch.

TIRES & WHEELS: 5

TIRES

Racing slicks permitted.

WHEELS

Must be automotive-type wheels suitable for street use. Minimum wheel size: 13 inches (unless originally equipped with smaller wheels and vehicle is equipped with original engine). The thread engagement on all wheel studs to the lug nut, or lug bolt to wheel hubs, must be equivalent to or greater than the diameter of the stud. Length of the stud/bolt does not determine permissibility; length of the engagement between the stud and lug determines permissibility. Snap-on hubcaps prohibited. See General Regulations 5:2.

INTERIOR: 6

SEATS

Properly braced, framed, and supported seats constructed of aluminum, fiberglass, carbon fiber, or double-layer poly (automotive accessory seats) permitted. See General Regulations 6:2.

UPHOLSTERY

Optional. See General Regulations 6:2.

WINDOW NET

A ribbon-type or SFI 27.1 mesh-type window net is mandatory for any full-bodied car running 9.99 (*6.39) and quicker, or if vehicle runs 135 mph or faster. See General Regulations 6:3.

BODY: 7

BODY

Full-bodied vehicles only: Must have full top and windshield. Must have two driver exits. Four stock-production fenders mandatory, fiberglass duplicates permitted. Fenders may be trimmed for tire clearance; altered fenders must have edges re-rolled or beaded.

FIREWALL

Mandatory. See General Regulations 6:1, 7:4.

FLOOR

Mandatory. See General Regulations 6:1, 7:5.

HOOD

Optional. Carburetors must be covered by flash shield or scoop. Hood scoop permitted. See General Regulations 4:1, 7:6.

WINDSHIELD, WINDOWS

Stock-bodied vehicles: mandatory; must be in good condition and free from cracks. May be replaced with shatterproof material, 1/8-inch-minimum thickness. OEM windshield may not be cut for scoops, carb, etc. Windshield/window tint must meet the applicable state requirements. Windows must be closed during races, need not be operable. Decals permitted on rear quarter and rear window only. See General Regulations 7:8.

ELECTRICAL: 8

BATTERIES

Batteries must be securely mounted; may not be located in driver compartment. Relocated battery(s) must be fastened to frame or frame structure with a minimum of two 3/8-inch-diameter bolts. See General Regulations 8:1.

DELAY BOX/DEVICES

Prohibited. Electronic devices include but are not limited to throttle stops, delay boxes, cross-over boxes, rpm or timer shifters, and rpm or pressure-activated switches. See General Regulations 8:2.

IGNITION

Timed ignition-interruption devices (stutter boxes) prohibited. Starting-line and/or "high-side" rev limiters permitted. Two-steps, rev limiters, or any other rpm-limiting devices, legal unto themselves but altered or installed so as to function as a down track rpm controller, prohibited.

INSTRUMENTS

One tachometer allowed. No wiring (other than the two-step/launch-control wire that splices into the transbrake or line-loc control wire) shall be connected.

MASTER CUTOFF

Mandatory on any car with a battery running 9.99 (6.39*) or quicker, any car exceeding 135 mph, or any car where the battery is relocated into the trunk area. See General Regulations 8:4.

TAILLIGHTS

One functional taillight mandatory. Flashing, blinking, or strobe lights prohibited. See General Regulations 8:6.

SUPPORT GROUP: 9

COMPUTER

Prohibited. See General Regulations 9:1.

DATA RECORDER

Data recorders permitted. See General Regulations 9:2.

FIRE-EXTINGUISHER SYSTEM

Permitted; must be securely mounted. See General Regulations 9:3.

PUSH BAR

Push bar must be designed to prevent push car from riding up on rear wheel of open-wheeled race cars. See General Regulations 9:8.

TOW VEHICLES

Prohibited.

WARM-UPS

See General Regulations 9:4, 9:12.

DRIVER: 10

CREDENTIALS

Valid NHRA competition license mandatory for cars running 9.99 (6.39*) or quicker. Valid state- or government-issued driver's license beyond a learner's-permit level

2026
Hot Rod Heritage Racing Series Rules Supplement

mandatory for cars running 10.00 (6.40*) or slower. NHRA license required to earn series points. See General Regulations 10:4.

DRIVER RESTRAINT SYSTEM

Seat belt mandatory in all cars. Driver restraint system meeting SFI Spec 16.1 or 16.5 mandatory in any car running 11.49 (7.35*) or quicker, in convertibles running 13.49 (8.25*) or quicker. SFI 16.1 restraint system, when required, includes crotch strap and must be updated at two-year intervals from date of manufacture. See General Regulations 10:5, 10:11.

HEAD PROTECTOR

Mandatory on any car with a roll bar or roll cage. See General Regulations 10:6.

HELMET

For all 10.00 to 13.99 closed-bodied cars, either an open-face or a full-face Snell: M2015, M2020, M2025, SA2015, SA2020, SA2025, or SFI: 31.1/2015, 31.1/2020, 41.1/2015, 41.1/2020 or FIA: 8860-2010, 8859-2015, 8860-2018, or 8859-2024 helmet with or without a shield is mandatory.

For all 9.99 and quicker closed-bodied cars, a full-face Snell: M2015, M2020, M2025, SA2015, SA2020, SA2025, or FIA: 8860-2010, 8859-2015, 8860-2018, or 8859-2024 helmet mandatory; shield permitted (goggles prohibited).

For all 9.99 and quicker supercharged cars, a full-face Snell: SA2015, SA2020, SA2025, or FIA: 8860-2010, 8859-2015, 8860-2018, or 8859-2024 helmet mandatory; shield permitted (goggles prohibited).

NECK COLLAR

Neck collar meeting SFI Spec 3.3 mandatory in all cars running 9.99 (6.39*) or quicker or cars exceeding 135 mph. A head and neck restraint device/system may be used in lieu of a neck collar. See General Regulations 10:8.

PROTECTIVE CLOTHING

Full-length pants; short- or long-sleeved shirt; closed shoes; and socks mandatory. No shorts or tank tops. No open-toe or open-heel shoes or sandals. Synthetic clothing not recommended. See General Regulations 10:10.

10.00 (6.40*) TO 13.99 (8.59*); ALL E.T. NON-OEM

SUPERCHARGED WITH AN OEM OR .024-INCH STEEL FIREWALL: Jacket meeting SFI Spec 3.2A/1 mandatory.

10.00 (6.40*) TO 13.99 (8.59*); ALL E.T. SUPERCHARGED WITHOUT A FULL OEM

OR .024-INCH STEEL FIREWALL: Jacket meeting SFI Spec 3.2A/5 and gloves meeting SFI Spec 3.3/1 mandatory.

9.99 (6.39*) AND QUICKER; CLOSED-BODIED WITHOUT AN OEM OR FULL .024-

INCH STEEL FIREWALL WITH SUPERCHARGER: Jacket and pants meeting SFI Spec 3.2A/15, and gloves and shoes or boots meeting SFI Spec 3.3/5 mandatory.

10.00 (6.40*) TO 11.49 (7.35*); ALL E.T. NATURALLY ASPIRATED, OEM SUPERCHARGED, WITH A FULL OEM OR .024-INCH STEEL FIREWALL: Jacket meeting SFI Spec 3.2A/1 mandatory.

9.99 (6.39*) TO 7.50 (4.50*) OR ANY VEHICLE EXCEEDING 135 MPH: Jacket and pants meeting SFI Spec 3.2A/5 and gloves meeting SFI Spec 3.3/1 mandatory, except as noted above.

ANY VEHICLE WITH AN AUTOMATIC TRANSMISSION IN DRIVER COMPARTMENT (NO FLOOR COVERING TRANSMISSION): Jacket and pants or suit meeting SFI Spec 3.2A/15, gloves meeting SFI Spec 3.3/5, and boots or shoes meeting SFI Spec 3.3/5 mandatory.

9.99 AND FASTER, ANY VEHICLE, SUPERCHARGED WITH ALCOHOL: Suit meeting SFI Spec 3.2A/15, and gloves and boots meeting SFI Spec 3.3/5 mandatory.
* = eighth-mile equivalent

SECTION 2: GAS ELIMINATOR

DESIGNATION

A/Gas, B/Gas, C/Gas, D/Gas, preceded by number.

CLASSES

A/Gas: 7.60 standard

B/Gas: 8.60 standard

C/Gas: 9.60 standard

D/Gas: 10.60 standard

Competition is based on using a four-tenths heads-up Pro Tree.

Reserved for 1984 and older coupe or sedan only that must readily resemble intended body style.

REQUIREMENTS & SPECIFICATIONS

ENGINE: 1

ENGINE

One internal-combustion automotive-type engine permitted. Harmonic balancer meeting SFI Spec 18.1 mandatory. See General Regulations 1:1.

EXHAUST SYSTEM

Competition exhaust permitted. Exhaust must be directed out of car to rear, away from driver and fuel tank. See General Regulations 1:3.

FUEL

Racing gasoline, gasoline, alcohol, gasohol, diesel, ethanol, natural gas, and propane permitted. Nitromethane prohibited.

FUEL SYSTEM

2026
Hot Rod Heritage Racing Series Rules Supplement

All fuel-tank filler necks located inside trunk must have filler neck vented to outside of body. Vented caps prohibited. All batteries, fuel lines, fuel pumps, or filler necks located inside trunk require complete bulkhead of at least .024-inch steel or .032-inch aluminum to isolate driver compartment from trunk. Fuel lines must be located outside driver compartment. Fuel tanks must be within confines of the body. No pressurized fuel tanks allowed. See General Regulations 1:5.

LIQUID OVERFLOW

Catch can mandatory for coolant overflow; one-pint (16-ounce) minimum capacity. See General Regulations 1:7.

OIL RETENTION DEVICE

A properly fitting, SFI Spec 7.1, 7.2, or NHRA-accepted lower engine oil retention device is mandatory, may use a belly pan in lieu of a device attached to the engine. The belly pan must extend from framerail to framerail and extend forward of the harmonic balancer and rearward to rear engine plate and must incorporate a minimum 2-inch-high lip on all sides. A nonflammable, oil-absorbent liner mandatory inside of retention device. See General Regulations 1:8.

NITROUS OXIDE

Nitrous oxide prohibited.

THROTTLE

Positive throttle return required. Each car must have a foot throttle incorporating a positive-acting return spring attached directly to the carburetor/injector throttle arm. Throttle control must be manually operated by driver's foot, incorporating a positive-action return system. See General Regulations 1:12.

SUPERCHARGER

Permitted on gasoline-, racing-gasoline-, and alcohol-burning cars. Rotors must be driven from the front; both external drive and internal gearing. Supercharger restraint system meeting SFI Spec 14.1 mandatory on supercharger when alcohol is used as fuel. Manifold burst panel mandatory. Supercharger restraint straps must be covered with a fire-resistant material. The blower restraint straps and fuel lines must be installed such that when the restraint straps are fully extended no load is placed on any of the fuel lines.

Supercharger belt guard that protects all fuel, oil, and water lines required. No composite materials in injector hat and/or scoop allowed. Composite materials include but are not limited to carbon fiber, Kevlar, and weave-graphite fiber. Hat/scoop must be nostalgic in appearance. Internal modifications permitted. Scoops limited to 12.5 inches above throttle body. Air intake limited to 65 square inches. See General Regulations 1:10.

VALVE COVERS

Cast or fabricated metal valve covers, using all attachment bolt holes, mandatory on supercharged, methanol-burning cars.

DRIVETRAIN: 2

CLUTCH, FLYWHEEL, FLYWHEEL SHIELD

Flywheel and clutch meeting SFI Spec 1.1 or 1.2 (two-disc maximum) mandatory on any car running 11.49 (7.35*) or quicker. Flywheel shield meeting SFI Spec 6.1, 6.2,

2026
Hot Rod Heritage Racing Series Rules Supplement

6.3, or 9.1 mandatory on all cars running 11.49 (7.35*) or quicker. See General Regulations 2:3, 2:5, 2:6, 2:10.

DRIVELINE

Driveline loop mandatory. See General Regulations 2:4.

REAR END

Aftermarket axles and axle-retention device mandatory on any car running 10.99 (6.99*) or quicker or any car with locked differential. See General Regulations 2:11.

TRANSMISSION, AFTERMARKET PLANETARY

Transmission shield meeting SFI Spec 4.1 mandatory on any supercharged vehicle or any vehicle burning methanol, running 9.99 seconds or quicker, and equipped with aftermarket planetary transmission. See General Regulations 2:12, 2:13.

TRANSMISSION, AUTOMATIC

Spring-loaded, positive reverse lockout device and functional neutral safety switch mandatory. Transmission shield meeting SFI Spec 4.1 mandatory. Automatic transmission flexplate meeting SFI Spec 29.1 and flexplate shield meeting SFI Spec 30.1 mandatory on cars running 9.99 (6.39*) or quicker or any car exceeding 135 mph. See General Regulations 2:12, 2:14.

BRAKES AND SUSPENSION: 3

BRAKES

Four-wheel hydraulic brakes mandatory on any bodied car running 7.99 (4.99*) or quicker. Minimum two rear-wheel (one caliper per wheel) hydraulic brakes mandatory on any car running slower than 8.00 (5.00*) seconds. See General Regulations 3:1.

STEERING

See General Regulations 3:3, 4:1.

SUSPENSION, STOCK-BODIED CARS

Full automotive-type suspension mandatory. Minimum one operating hydraulic shock absorber per wheel. Lightening of stock components prohibited. Rigid-mounted suspensions prohibited. See General Regulations 3:2, 3:4, 3:5.

WHEELIE BARS

Permitted. Wheels must be nonmetallic. See General Regulations 3:6.

FRAME: 4

BALLAST

Permitted. See General Regulations 4:2.

GROUND CLEARANCE

Minimum 3 inches from front of car to 12 inches behind centerline of front axle, 2 inches for remainder of car, except oil pan and headers. See General Regulations 4:5.

PARACHUTE

Mandatory on any car that runs 150 mph or faster. See General Regulations 4:8.

ROLL BAR

Roll bar mandatory in all cars running 11.00 (7.00*) to 11.49 (7.35*), in convertibles running 11.00 (7.00*) to 13.49 (8.25*). Permitted in all cars. See General Regulations 4:10, 10:6.

ROLL CAGE

2026
Hot Rod Heritage Racing Series Rules Supplement

Roll cage mandatory if vehicle has altered floor or if vehicle runs 135 mph or faster. In D/Gas, if vehicle is equipped with unaltered firewall, floor, and body (from firewall rearward, wheel tubs permitted), roll bar permitted in place of roll cage. In convertibles running 10.99 (6.99*) or quicker or exceeding 135 mph, roll cage mandatory. Cars running between 7.50 (4.50*) and 9.99 (6.39*) must have chassis inspected every three years by NHRA and have a serialized sticker affixed to cage before participation. Plating of chassis prohibited for all cars manufactured after Jan. 1, 2003. In A/Gas, vehicle must meet either SFI Spec 25.4 or 25.5. All other classes, any vehicles running 8.49 to 7.50 (5.49* to 4.50*) and/or exceeding 180 mph must meet appropriate SFI Spec for body used. All others must conform to specs for body style used, as listed in General Regulations 4:11, 10:6.

ROLL-CAGE PADDING

Roll-cage padding meeting SFI Spec 45.1 mandatory on any vehicle running 9.99 (*6.39) and quicker. Padding must be used anywhere driver's helmet may come in contact with roll-cage components. See General Regulations 4:11, 10:6.

WHEELBASE

Minimum 90 inches, unless car has original engine. Maximum wheelbase variation from left to right: 1 inch.

TIRES & WHEELS: 5

TIRES

Racing slicks permitted.

WHEELS

Must be automotive-type wheels suitable for street use. Minimum wheel size: 13 inches (unless originally equipped with smaller wheels and vehicle is equipped with original engine). The thread engagement on all wheel studs to the lug nut, or lug bolt to wheel hubs, must be equivalent to or greater than the diameter of the stud. Length of the stud/bolt does not determine permissibility; length of the engagement between the stud and lug determines permissibility. Snap-on hubcaps prohibited. See General Regulations 5:2.

INTERIOR: 6

SEATS

Properly braced, framed, and supported seats constructed of aluminum, fiberglass, carbon fiber, or double-layer poly (automotive accessory seats) permitted. See General Regulations 6:2.

UPHOLSTERY

Optional. See General Regulations 6:2.

WINDOW NET

A ribbon-type or SFI 27.1 mesh-type window net is mandatory for any full-bodied car running 7.50 (*4.50) to 9.99 (*6.39) or if vehicle runs 135 mph or faster. See General Regulations 6:3.

BODY: 7

BODY

2026
Hot Rod Heritage Racing Series Rules Supplement

Full-bodied vehicles: Must have full top and windshield. All full-bodied cars must have two driver exits. Four stock-production fenders mandatory, fiberglass duplicates permitted. Fenders may be trimmed for tire clearance; altered fenders must have edges re-rolled or beaded.

FIREWALL

Mandatory. See General Regulations 6:1, 7:4.

FLOOR

Mandatory. See General Regulations 6:1, 7:5.

HOOD

Optional. Carburetors must be covered by flash shield or scoop. Hood scoop permitted. See General Regulations 4:1, 7:6.

WINDSHIELD, WINDOWS

Stock-bodied vehicles: mandatory; must be in good condition and free from cracks. May be replaced with shatterproof material, 1/8-inch-minimum thickness. OEM windshield may not be cut for scoops, carb, etc. Windshield/window tint must meet the applicable state requirements. Windows must be closed during races, need not be operable. Decals permitted on rear quarter and rear window only. See General Regulations 7:8.

ELECTRICAL: 8

BATTERIES

Batteries must be securely mounted; may not be located in driver compartment. Relocated battery(s) must be fastened to frame or frame structure with a minimum of two 3/8-inch-diameter bolts. See General Regulations 8:1.

DELAY BOX/DEVICES

Prohibited. Electronic devices include but are not limited to throttle stops, delay boxes, cross-over boxes, rpm or timer shifters, and rpm or pressure-activated switches. See General Regulations 8:2.

IGNITION

Timed ignition-interruption devices (stutter boxes) prohibited. Starting-line and/or "high-side" rev limiters permitted. Two-steps, rev limiters, or any other rpm-limiting devices, legal unto themselves but altered or installed so as to function as a down track rpm controller, prohibited.

INSTRUMENTS

One tachometer allowed. No wiring (other than the two-step/launch-control wire that splices into the transbrake or line-loc control wire) shall be connected.

MASTER CUTOFF

Mandatory on any car with a battery running 9.99 (6.39*) or quicker, any car exceeding 135 mph, or any car where the battery is relocated into the trunk area. See General Regulations 8:4.

TAILLIGHTS

One functional taillight mandatory. Flashing, blinking, or strobe lights prohibited. See General Regulations 8:6.

SUPPORT GROUP: 9

COMPUTER

Prohibited. See General Regulations 9:1.

DATA RECORDER

Data recorders permitted. See General Regulations 9:2.

FIRE-EXTINGUISHER SYSTEM

Permitted; must be securely mounted. See General Regulations 9:3.

PUSH BAR

Push bar must be designed to prevent push car from riding up on rear wheel of open-wheeled race cars. See General Regulations 9:8.

TOW VEHICLES

Permitted

WARM-UPS

See General Regulations 9:4, 9:12.

DRIVER: 10

CREDENTIALS

Valid NHRA competition license mandatory in A/Gas, B/Gas, and C/Gas or any vehicle running faster than 135 mph. Required in D/Gas to earn series points. Valid state- or government-issued driver's license beyond a learner's-permit level mandatory for cars running 10.00 (6.40*) or slower. See General Regulations 10:4.

DRIVER RESTRAINT SYSTEM

Seat belt mandatory in all cars. Driver restraint system meeting SFI Spec 16.1 or 16.5 mandatory. SFI 16.1 restraint system, when required, includes crotch strap and must be updated at two-year intervals from date of manufacture. See General Regulations 10:5, 10:11.

HEAD PROTECTOR

Mandatory on any car with a roll bar or roll cage. See General Regulations 10:6.

HELMET

For all 10.00 to 13.99 closed-bodied cars, either an open-face or a full-face Snell: M2015, M2020, M2025, SA2015, SA2020, SA2025, or SFI: 31.1/2015, 31.1/2020, 41.1./2015, 41.1/2020 or FIA: 8860-2010, 8859-2015, 8860-2018, or 8859-2024 helmet with or without a shield is mandatory.

For all 9.99 and quicker closed-bodied cars, a full-face Snell: M2015, M2020, M2025, SA2015, SA2020, SA2025, or FIA: 8860-2010, 8859-2015, 8860-2018, or 8859-2024 helmet mandatory; shield permitted (goggles prohibited).

For all 9.99 and quicker supercharged cars, a full-face Snell: SA2015, SA2020, SA2025, or FIA: 8860-2010, 8859-2015, 8860-2018, or 8859-2024 helmet mandatory; shield permitted (goggles prohibited).

NECK COLLAR/HEAD AND NECK RESTRAINT DEVICE/SYSTEM

2026
Hot Rod Heritage Racing Series Rules Supplement

Neck collar meeting SFI Spec 3.3 mandatory in A/Gas, B/Gas, and C/Gas or cars exceeding 135 mph. A head and neck restraint device/system may be used in lieu of a neck collar. See General Regulations 10:8.

Head and neck restraint device/system meeting SFI Spec 38.1 mandatory in A/Gas.

PROTECTIVE CLOTHING

Shorts, bare legs, tank tops, or bare torsos prohibited when driving in competition. All drivers are required to wear full-length pants, shoes, and socks. Nylon or nylon-type clothing and open-toe shoes prohibited. See General Regulations 10:10.

10.00 (6.40*) TO 13.99 (8.59*); ALL E.T. NON-OEM SUPERCHARGED WITH AN OEM OR .024-INCH STEEL FIREWALL: Jacket meeting SFI Spec 3.2A/1 mandatory.

10.00 (6.40*) TO 13.99 (8.59*); ALL E.T. SUPERCHARGED WITHOUT A FULL OEM OR .024-INCH STEEL FIREWALL: Jacket meeting SFI Spec 3.2A/5 and gloves meeting SFI Spec 3.3/1 mandatory.

9.99 (6.39*) TO 7.50 (4.50*); CLOSED-BODIED WITHOUT AN OEM OR FULL .024-INCH STEEL FIREWALL WITH SUPERCHARGER: Jacket and pants meeting SFI Spec 3.2A/15, and gloves and shoes or boots meeting SFI Spec 3.3/5 mandatory.

10.00 (6.40*) TO 11.49 (7.35*); ALL E.T. NATURALLY ASPIRATED, OEM SUPERCHARGED, WITH A FULL OEM OR .024-INCH STEEL FIREWALL: Jacket meeting SFI Spec 3.2A/1 mandatory.

9.99 (6.39*) TO 7.50 (4.50*) OR ANY VEHICLE EXCEEDING 135 MPH: Jacket and pants meeting SFI Spec 3.2A/5 and gloves meeting SFI Spec 3.3/1 mandatory, except as noted above.

ANY VEHICLE WITH AN AUTOMATIC TRANSMISSION IN DRIVER COMPARTMENT (NO FLOOR COVERING TRANSMISSION): Jacket and pants or suit meeting SFI Spec 3.2A/15, gloves meeting SFI Spec 3.3/5, and boots or shoes meeting SFI Spec 3.3/5 mandatory.

9.99 AND FASTER, ANY VEHICLE, SUPERCHARGED WITH ALCOHOL: Suit meeting SFI Spec 3.2A/15, and gloves and boots meeting SFI Spec 3.3/5 mandatory.

*** = eighth-mile equivalent**

SECTION 3: NOSTALGIA ELIMINATOR

DESIGNATION

N/E, N/E II, N/E III, preceded by number

CLASSES

N/E: 7.60 standard

N/E II: 8.60 standard

N/E III: 9.60 standard

Competition is based on using a four-tenths heads-up Pro Tree.

N/E: Reserved for front-engine center-steer cars only (dragsters, altered, and 1984 and older Funny Cars). Left-hand- and right-hand-steered roadsters and altered will be allowed to run in N/E II and N/E III.

REQUIREMENTS & SPECIFICATIONS

ENGINE: 1

ENGINE

One internal-combustion automotive-type engine permitted. Harmonic balancer meeting SFI Spec 18.1 mandatory. See General Regulations 1:1.

EXHAUST SYSTEM

Competition exhaust permitted. Exhaust must be directed out of car to rear, away from driver and fuel tank. See General Regulations 1:3.

FUEL

Racing gasoline, gasoline, alcohol, gasohol, diesel, ethanol, natural gas, and propane permitted. Nitromethane accepted.

FUEL SYSTEM

Fuel lines must be located outside driver compartment. Fuel tank must be within the confines of the body. No pressurized fuel tanks allowed. See General Regulations 1:5.

LIQUID OVERFLOW

Catch can mandatory for coolant overflow; one-pint (16-ounce) minimum capacity. See General Regulations 1:7.

OIL RETENTION DEVICE

A properly fitting, SFI Spec 7.1, 7.2, or NHRA-accepted lower engine oil retention device is mandatory. Dragsters may utilize a belly pan in lieu of a device attached to the engine. Belly pan must extend from framerail to framerail and extend forward of the harmonic balancer and rearward of the flywheel and must incorporate minimum 2-inch-high lips on all sides. See General Regulations 1:8.

NITROUS OXIDE

Nitrous oxide prohibited.

THROTTLE

Positive throttle return required. Each car must have a foot throttle incorporating a positive-acting return spring attached directly to the carburetor/injector throttle arm. Throttle control must be manually operated by driver's foot, incorporating a positive-action return system. See General Regulations 1:12.

SUPERCHARGER

Permitted on gasoline-, racing-gasoline-, and alcohol-burning cars. Rotors must be driven from the front; both external drive and internal gearing. Supercharger restraint

2026
Hot Rod Heritage Racing Series Rules Supplement

system meeting SFI Spec 14.1 mandatory on supercharger when alcohol is used as fuel or Roots-type 6.71 with nitromethane. Manifold burst panel mandatory. Supercharger restraint straps must be covered with a fire-resistant material. The blower restraint straps and fuel lines must be installed such that when the restraint straps are fully extended no load is placed on any of the fuel lines. Supercharger belt guard that protects all fuel, oil, and water lines required. No composite materials in injector hat and/or scoop allowed. Composite materials include but are not limited to carbon fiber, Kevlar, and weave-graphite fiber. Hat/scoop must be nostalgic in appearance. Internal modifications permitted. Scoops limited to 12.5 inches above throttle body. Air intake limited to 65 square inches. See General Regulations 1:10.

VALVE COVERS

Cast or fabricated metal valve covers, using all attachment bolt holes, mandatory on supercharged, methanol-burning cars.

DRIVETRAIN: 2

CLUTCH, FLYWHEEL, FLYWHEEL SHIELD

Flywheel and clutch meeting SFI Spec 1.1 or 1.2 (two-disc maximum) mandatory. Flywheel shield meeting SFI Spec 6.1, 6.2, 6.3, or 9.1 mandatory. See General Regulations 2:3, 2:5, 2:6, 2:10.

DRIVELINE

Driveline loop mandatory. See General Regulations 2:4.

REAR END

Aftermarket axles and axle-retention device mandatory. See General Regulations 2:11.

TRANSMISSION, AFTERMARKET PLANETARY

Transmission shield meeting SFI Spec 4.1 mandatory on any supercharged vehicle or any vehicle burning methanol, running 9.99 seconds or quicker, and equipped with aftermarket planetary transmission. See General Regulations 2:12, 2:13.

TRANSMISSION, AUTOMATIC

Spring-loaded, positive reverse lockout device and functional neutral safety switch mandatory. Transmission shield meeting SFI Spec 4.1 mandatory. Automatic transmission flexplate meeting SFI Spec 29.1 and flexplate shield meeting SFI Spec 30.1 mandatory on cars running 9.99 (6.39*) or quicker or any car exceeding 135 mph. See General Regulations 2:12, 2:14.

BRAKES AND SUSPENSION: 3

BRAKES

Minimum two rear-wheel (one caliper per wheel) hydraulic brakes mandatory. See General Regulations 3:1.

STEERING

See General Regulations 3:3, 4:1.

WHEELIE BARS

Permitted. Wheels must be nonmetallic. See General Regulations 3:6.

FRAME: 4

BALLAST

2026
Hot Rod Heritage Racing Series Rules Supplement

Permitted. See General Regulations 4:2.

GROUND CLEARANCE

Minimum 3 inches from front of car to 12 inches behind centerline of front axle, 2 inches for remainder of car, except oil pan and headers. See General Regulations 4:5.

PARACHUTE

Mandatory on any car that runs 150 mph or faster. See General Regulations 4:8.

ROLL CAGE

Mandatory. Must have chassis inspected every three years by NHRA and have a serialized sticker affixed to cage before participation. Plating of chassis prohibited for all cars manufactured after Jan. 1, 2003. Vehicle must meet appropriate SFI Specification. See General Regulations 4:11, 10:6.

ROLL-CAGE PADDING

Roll-cage padding meeting SFI Spec 45.1 mandatory on any vehicle running 9.99 (*6.39) and quicker. Padding must be used anywhere driver's helmet may come in contact with roll-cage components. See General Regulations 4:11, 10:6.

WHEELBASE

Minimum 90 inches, unless car has original engine. Maximum wheelbase variation from left to right: 1 inch; dragsters, 2 inches. Minimum front tread width: 26 inches on any dragster.

TIRES & WHEELS: 5

TIRES

Minimum diameter of 13 inches on front tires of any dragster. See General Regulations 5:1.

WHEELS

Wire wheels permitted on front of dragsters only, provided total weight of car does not exceed 1,800 pounds, excluding driver. The thread engagement on all wheel studs to the lug nut, or lug bolt to wheel hubs, must be equivalent to or greater than the diameter of the stud. Length of the stud/bolt does not determine permissibility; length of the engagement between the stud and lug determines permissibility. Snap-on hubcaps prohibited. See General Regulations 5:2.

INTERIOR: 6

UPHOLSTERY

Optional. See General Regulations 6:2.

BODY: 7

BODY

Altered-body vehicles: May be chopped, channeled, sectioned, streamlined, etc. Sedan delivery, pickup trucks (maximum, one ton), or sedan pickups (Ranchero, El Camino) permitted. Fiberglass bodies permitted. Door hinges on any lift-off door must have safety pins or locks.

Dragsters: Body and cowl must be constructed of metal, fiberglass, or carbon fiber and extend forward to firewall. Driver compartment must be designed to prevent driver's

2026
Hot Rod Heritage Racing Series Rules Supplement

body or limbs from making contact with wheels, tires, exhaust system, or track surface should an incident occur. Subflooring independent of car body is mandatory in dragster that allows driver's legs to rest on belly pan or chassis. Front overhang not to exceed 30 inches, measured from centerline of front spindle to forward-most point of car. On front-engine cars, intake scoop may not extend more than 11 inches above height of carburetor top. Front wheel fairings prohibited.

FIREWALL

Mandatory. See General Regulations 6:1, 7:4.

FLOOR

Mandatory. See General Regulations 6:1, 7:5.

WINDSHIELD, WINDOWS

Optional. Windscreen mandatory. See General Regulations 7:7, 7:8.

ELECTRICAL: 8

BATTERIES

Batteries must be securely mounted; may not be located in driver compartment. See General Regulations 8:1.

DELAY BOX/DEVICES

Prohibited. Electronic devices include but are not limited to throttle stops, delay boxes, cross-over boxes, rpm or timer shifters, and rpm or pressure-activated switches. See General Regulations 8:2.

IGNITION

Timed ignition-interruption devices (stutter boxes) prohibited. Starting-line and/or "high-side" rev limiters permitted. Two-steps, rev limiters, or any other rpm-limiting devices, legal unto themselves but altered or installed so as to function as a down track rpm controller, prohibited.

INSTRUMENTS

One tachometer allowed. No wiring (other than the two-step/launch-control wire that splices into the transbrake or line-loc control wire) shall be connected.

MASTER CUTOFF

Mandatory. See General Regulations 8:4.

TAILLIGHTS

One functional taillight mandatory. Flashing, blinking, or strobe lights prohibited. See General Regulations 8:6.

SUPPORT GROUP: 9

COMPUTER

Prohibited. See General Regulations 9:1.

DATA RECORDER

Data recorders permitted. See General Regulations 9:2.

FIRE-EXTINGUISHER SYSTEM

Permitted; must be securely mounted. See General Regulations 9:3.

TOW VEHICLES

Permitted. Full-size tow vehicle permitted in N/E; small tow vehicle allowed in N/E II and N/E III.

WARM-UPS

See General Regulations 9:4, 9:12.

DRIVER: 10

ARM RESTRAINTS

Mandatory. See General Regulations 10:3.

CREDENTIALS

Valid NHRA competition license mandatory. See General Regulations 10:4.

DRIVER RESTRAINT SYSTEM

Driver restraint system meeting SFI Spec 16.1 mandatory. SFI 16.1 restraint system must be updated at two-year intervals from date of manufacture. See General Regulations 10:5, 10:11.

HEAD PROTECTOR

Mandatory. See General Regulations 10:6.

HELMET

For all 9.99 and quicker open-bodied cars, a full-face Snell: M2015, M2020, M2025, SA2015, SA2020, SA2025, or FIA: 8860-2010, 8859-2015, 8860-2018, or 8859-2024 helmet mandatory; shield mandatory (goggles prohibited).

For all 9.99 and quicker supercharged cars, a full-face Snell: SA2015, SA2020, SA2025, or FIA: 8860-2010, 8859-2015, 8860-2018, or 8859-2024 helmet mandatory; shield mandatory (goggles prohibited).

NECK COLLAR/HEAD AND NECK RESTRAINT DEVICE/SYSTEM

Neck collar meeting SFI Spec 3.3 mandatory. A head and neck restraint device/system may be used in lieu of a neck collar. See General Regulations 10:8.

Head and neck restraint device/system meeting SFI Spec 38.1 mandatory in N/E I. PROTECTIVE CLOTHING

If no specific Protective Clothing requirements are stated for a particular class, then the minimum requirements are as follows: full-length pants; short- or long-sleeved shirt; closed shoes; and socks. No shorts. No bare legs. No bare torsos. No tank tops. No open-toe or open-heel shoes or sandals. Synthetic clothing not recommended. See General Regulations 10:10.

An SFI 3.3 head sock or SFI 3.3 skirted helmet is required on all open-bodied cars or all cars 7.49 & quicker, where a neck collar is not used.

9.99 (6.39*) TO 7.50 (4.50*) FRONT-ENGINE, OPEN-BODIED VEHICLES

SUPERCHARGED: Jacket and pants meeting SFI Spec 3.2A/15, gloves and shoes/boots meeting SFI Spec 3.3/15 mandatory.

9.99 (6.39*) TO 7.50 (4.50*) OR ANY VEHICLE EXCEEDING 135 MPH:

Jacket and pants meeting SFI Spec 3.2A/5 and gloves meeting SFI Spec 3.3/1 mandatory, except as noted above.

ALL OPEN-BODY VEHICLES: Gloves meeting SFI Spec 3.3/1 and arm restraints mandatory, except as noted above.

ANY VEHICLE WITH AN AUTOMATIC TRANSMISSION IN DRIVER COMPARTMENT (NO FLOOR COVERING TRANSMISSION): Jacket and pants or suit meeting SFI Spec 3.2A/15, gloves meeting SFI Spec 3.3/5, and boots or shoes meeting SFI Spec 3.3/5 mandatory.

9.99 AND FASTER, ANY VEHICLE, SUPERCHARGED WITH ALCOHOL:

Suit meeting SFI Spec 3.2A/15, gloves and boots meeting SFI Spec 3.3/5 mandatory.

* = eighth-mile equivalent

SECTION 4: 7.0 ELIMINATOR

DESIGNATION

7/E, preceded by car number.

Reserved for supercharged, methanol-burning, and injected nitromethane-burning front-engine dragsters, center-steer altered, and (1984 and older) Funny Cars permitted.

REQUIREMENTS & SPECIFICATIONS

ENGINE: 1

CYLINDER HEADS

Aftermarket alloy heads permitted.

ENGINE

Block may be cast or aluminum.

EXHAUST SYSTEM

Competition exhaust permitted. No collector-style headers allowed. Exhaust must be directed away from driver. See General Regulations 1:3.

FUEL SYSTEM

Fuel lines not permitted in driver's compartment. Fuel shutoff operable from the driver's seat mandatory. Fuel tank must be mounted above lower framerail and must be equipped with a positive locking screw-on cap. See General Regulations 1:5.

OIL RETENTION DEVICE

A properly fitting SFI Spec 7.1, 7.2 or NHRA-accepted lower engine oil retention device; may use a belly pan in lieu of a device attached to the engine. The belly pan must extend from framerail to framerail and extend forward of the harmonic balancer and rearward to rear engine plate and must incorporate a minimum 2-inch-high lip on all sides. A nonflammable, oil-absorbent liner mandatory inside of retention device. See General Regulations 1:8.

SUPERCHARGER

Roots-type, only. High helix permitted. Manifold burst panel meeting SFI Spec 23.1, plus restraint system meeting SFI Spec 14.1 mandatory. Belt guard that protects all fuel, oil, and water lines required.

THROTTLE

Throttle control must be manually operated by driver's foot: Electronics, pneumatics, hydraulics, or any other device may in no way affect the throttle operation. A mechanical device for controlling engine rpm during burnouts may be attached to the injector or throttle linkage but may not be driver-controlled.

VALVE COVERS

Cast or fabricated metal valve covers using all attachment bolt holes mandatory. Valve-cover gaskets, O-rings, etc. must be completely bonded/glued to either the valve cover or cylinder-head sealing surface. Vent tube adapters on the valve covers must either be fully welded to the valve covers or incorporate a gasket or O-ring that is bonded/glued to either the adapter or the valve cover. Valve covers must be fastened to the cylinder heads with studs and nuts in lieu of bolts where possible. Spark-plug tubes that penetrate the valve covers must have a restraining device to contain the spark-plug tube in the valve cover in the event the spark plug is discharged.

VENT-TUBE BREATHERS

NHRA-accepted catch-can/vent-tube system mandatory for all supercharged engines. Twist-on/quick-disconnect fittings between the vent-tube hoses and the valve-cover vent-tube adapters must incorporate a secondary locking device such as a hasp pin, ball lock pin, etc. Tape is not a satisfactory primary or secondary locking device. Double clamps are required on each end of all hoses used in the vent system, including the dry-sump vents. Minimum 1-inch-inside-diameter hoses are required from each valve cover to the catch-can inlets and/or framerails and from each framerail outlet to both catch-can inlets. Minimum catch-can(s) capacity is a 1-gallon sump. Catch cans must have adequate internal baffling. Minimum catch-can inlet configuration is one 1-inch-inside-diameter (or equivalent area) tubes. Minimum catch-can outlet/discharge configuration is one 1-inch-inside-diameter openings (or equivalent area). Vent tubes must be unobstructed from the interior of the valve cover to the interior of the catch can; i.e., no orifices, reduced areas, filler materials, etc.

DRIVETRAIN: 2

CLUTCH, FLYWHEEL, FLYWHEEL SHIELD

Flywheel and clutch meeting SFI Spec 1.4 and flywheel shield meeting SFI Spec 6.2 mandatory on all cars. Three discs maximum. Clutch must be manually operated by driver's foot: Electronics, pneumatics, hydraulics, or any other device may in no way affect the clutch system. Throw-out bearing must release all fingers, levers, stages, etc. simultaneously. Staged or variable release clutches of any description prohibited. Clutch/bellhousing exhaust filter mandatory.

DRIVELINE

A full cover of minimum .063-inch aluminum must enclose the driveline. Couplers mandatory. See General Regulations 2:4.

REAR END

Aftermarket axles and axle-retention device mandatory. See General Regulations 2:2, 2:11.

TRANSMISSION

Maximum forward gears limited to three. Reverser mandatory. OEM transmission case accepted. Automatic trans must be covered by a trans shield meeting SFI 4.1, also a flexplate meeting SFI spec 29.1 with a SFI 30.1 flexplate shield. Planetary transmission

2026
Hot Rod Heritage Racing Series Rules Supplement

permitted with a SFI spec 4.1 blanket required. Clutch hold-down device recommended. Automated shifters and/or timers-type shifting devices prohibited; each individual shift must be a function of the driver.

TRANSMISSION SHIELD

A one-piece ballistic shield covering all units mandatory. Must meet SFI Spec 4.1.

BRAKES AND SUSPENSION: 3

BRAKES

Automated brakes prohibited. Application and release of brakes must be a function of the driver. Dual spots or equivalent oval pucks mandatory; minimum two rear-wheel hydraulic brakes. Hand brake, if used, must be located inside body or driver compartment. Steel brake lines mandatory. Brake lines passing engine or blower drive must be shielded. Four-wheel brakes with dual master cylinder mounted above framerails mandatory on any full-bodied vehicle.

STEERING

Commercially available quick-disconnect steering wheel meeting SFI Spec 42.1 or steering box crossmember mandatory. Use of a pinned steering crossmember in lieu of an SFI quick-disconnect steering wheel prohibited on front-engine cars. A device must be used to prevent a long steering shaft from injuring driver in case of frontal impact.

SUSPENSION

Front suspension optional.

WHEELIE BARS

Permitted. Wheels must be nonmetallic.

FRAME: 4

BALLAST

Permitted. Maximum total ballast (welded or bolted), 250 pounds.

GROUND CLEARANCE

Minimum 3 inches from front of car to 12 inches behind centerline of front axle, 2 inches for remainder of car, except oil pan.

PARACHUTE

Fire-resistant protective covers must be on all parachute packs and unpacked shroud lines.

ROLL CAGE

Chassis must meet SFI Spec 10.1 (front-engine, driver in front of rear end) or SFI Spec 10.2 (altered) or SFI Spec 2.2 or 2.4 (front-engine, driver behind rear end). Plating of chassis prohibited; painting permitted. Chassis must be inspected every three years by NHRA and have serialized sticker affixed to frame before participation. Roll-cage padding meeting SFI Spec 45.1 mandatory where driver's helmet may come in contact with roll-cage components. Additional padding, mounted on flat stock and fastened to the roll cage on both sides of the driver's helmet, mandatory. Additional padding must be NHRA accepted (with manufacturer's name displayed), securely mounted using bolts or locking fasteners, and must include a flame-retardant covering. A current list of NHRA-accepted lateral head supports is available on NHRARacer.com. All wiring must

2026
Hot Rod Heritage Racing Series Rules Supplement

be external of the framerails; routing of cables, hydraulic, or pneumatic lines inside the chassis is permitted. Pressurization of framerails in lieu of air bottles is prohibited.

WHEELBASE

Maximum 225 inches.

TIRES & WHEELS: 5

TIRES

Tires must be specified for racing use by manufacturer.

INTERIOR: 6

SEATS

Magnesium seats prohibited. See General Regulations 6:2.

UPHOLSTERY

Optional. See General Regulations 6:2.

BODY: 7

BODY

Body and cowl must be metal, carbon fiber, or fiberglass. Driver compartment, frame structure, roll bars, and body must be designed to prevent driver's body or limbs from contact with track surface. Subflooring, inside but independent of body, mandatory where driver's legs rest on belly pan or chassis. Front overhang not to exceed 40 inches, measured from centerline of front spindle to forward-most point of car. Ground effects of any description prohibited. Ground effects include but are not limited to rocker skirts, belly pans, sheet-metal work under the body that produces a "tunnel" for the passage of air, etc.

WINDSCREEN

Mandatory.

WINGS/SUPPORTS

Maximum canard wing restricted to 400 square inches per side. Canards may not extend more than 1 inch outside rear tire. Front wing must be below front tire and may not extend outside of front tires. Total front-wing surface may not exceed 400 square inches. Canards and front wing, only aero surfaces allowed, except for altereds, a wing restricted to 750 square inches is permitted. Adjustment of spoiler during run prohibited.

ELECTRICAL: 8

IGNITION

Single magneto or single coil ignition only. Mag advance or retard must be function of the driver. No digital or programmable ignitions allowed. Single over-rev (high-side only) rpm chip box allowed.

SUPPORT GROUP: 9

COMPUTERS

Computers prohibited.

DATA RECORDERS

2026
Hot Rod Heritage Racing Series Rules Supplement

Data recorders permitted. Cannot perform any function in fuel, clutch, or driver management.

FIRE EXTINGUISHER SYSTEM

Fire extinguisher system meeting SFI Spec 17.1 mandatory. Minimum 20-pound or more NHRA-accepted fire extinguishing system mandatory on all front-engine open-bodied alcohol-burning supercharged cars. Activation cables must be protected in bellhousing and engine area. Activation cables and distribution tubing must be steel. Must be installed per manufacturer's specifications. Carbon-fiber bottles prohibited. See General Regulations 9:3.

TOW VEHICLES

Permitted.

WARM-UPS

See General Regulations 9:4, 9:12.

DRIVER: 10

ARM RESTRAINTS

Mandatory in any open-bodied cars and Funny Cars.

CREDENTIALS

Valid NHRA Advanced E.T. license mandatory.

DRIVER RESTRAINT SYSTEM

Driver-restraint system meeting SFI Spec 16.1 or 16.5 mandatory. All belts must be covered with a fire-resistant covering. Restraint system must be updated at two-year intervals from date of manufacture. See General Regulations 10:5.

HELMET

A full-face helmet with shield meeting Snell: SA2015, SA2020, SA2025, SFI: 31.1/2015, 31.1/2020 or FIA: 8860-2010, 8859-2015, 8860-2018, or 8859-2024 mandatory. See General Regulations 10:7.

HEAD AND NECK RESTRAINT DEVICE/SYSTEM

A head and neck restraint device/system is mandatory. At all times that the driver is in the race vehicle, from the ready line until the vehicle is on the return road, driver must properly utilize an SFI-approved head and neck restraint device/system, including connecting the helmet as required for full functionality of the device. The device/system must meet SFI Spec 38.1 and must display a valid SFI label. The head and neck restraint device/system, when connected, must conform to the manufacturer's mounting instructions, and it must be configured, maintained, and used in accordance with the manufacturer's instructions.

PROTECTIVE CLOTHING

Driver's suit meeting SFI Spec 3.3/20, gloves 3.2A/15, boots 3.3/15, and head sock 3.3. All jacket and pants or driver suit that meet the SFI Spec 3.2A/20 must be recertified on a five-year interval. Head sock is not mandatory when helmet is manufactured with a skirt labeled as meeting SFI Spec. 3.3.

SECTION 5: JUNIOR FUEL ELIMINATOR

DESIGNATION

2026
Hot Rod Heritage Racing Series Rules Supplement

Class designation (below) preceded by car number. Three classes – front-engine methanol-burning dragsters.

Handicap starts, using .4 Pro Tree. Handicaps based on recognized class records at time of event.

CLASSES

A/ND: 3.50 pounds per cubic inch, 1,300-pound minimum weight (refer to NHRA A/ND rules)

B/ND: 3.50 pounds per cubic inch, 1,300-pound minimum weight. Limited to OEM cast-iron Hemi; 23-degree small-block Chevy, big-block Chevy and Ford may use aftermarket cast-iron cylinder head, but stock valve angles must be retained. Raised runner 23-degree small-block Chevy cast-iron heads permitted (refer to NHRA B/ND rules)

C/ND: 3.50 pounds per cubic inch, 1,350-pound minimum weight. 23-degree Chevy (no raised runner) OEM or aftermarket replacement style, OEM Ford or aftermarket replacement style heads. Other makes fall under same category as above. Plus or minus (+ or -) 3 degrees maximum allowance for milling of heads (refer to NHRA B/ND rules)

REQUIREMENTS & SPECIFICATIONS

ENGINE: 1

CYLINDER HEAD

Alloy heads prohibited. Cylinder heads limited to current technology. Any new cylinder-head design must be NHRA accepted prior to competition. Chevy SB2 heads prohibited.

ENGINE

One internal-combustion, reciprocating, automobile-type engine permitted. Cast-iron block mandatory. Maximum 430 cid. No collector-style headers allowed. Dry sumps and evacuation system permitted. See General Regulations 1:2.

EXHAUST SYSTEM

Collector-style headers prohibited. See General Regulations 1:3.

FUEL

Methanol mandatory; all other fuels prohibited. Propylene oxide and/or nitrous oxide prohibited. See General Regulations 1:6.

FUEL SYSTEM

Injector diameter limited to 2.875 inches as measured across throttle butterfly shaft; round butterflies only. Down nozzles prohibited. Fuel lines must be isolated from driver compartment. Artificial cooling or heating of fuel prohibited. Circulating pumps prohibited. Maximum one fuel pump. Electric/electronic control of fuel system prohibited. Pneumatic allowed, must be controlled by the driver. Mechanical fuel injection, with

individual stacks and cast manifold only, or NHRA accepted, mandatory. See General Regulations 1:5.

OIL RETENTION DEVICE

Effective January 1, 2008, a properly fitting, SFI Spec 7.1, 7.2, or NHRA accepted Lower Engine Oil Retention Device is mandatory. Dragsters may utilize a belly pan in lieu of a device attached to the engine. Belly pan must extend from frame rail to frame rail, and extend forward of the harmonic balancer and rearward of the flywheel, and must incorporate minimum 2-inch high lips on all sides. See General Regulations 1:8.

DRIVETRAIN: 2

DRIVELINE

A full cover must enclose the driveline if universal joints are used. Cover material must be minimum .063-inch steel or .125-inch aluminum. See General Regulations 2:4.

REAR END

Aftermarket axles and axle-retention device mandatory. Spool permitted. See General Regulations 2:2, 2:11.

TRANSMISSION

Limited to automotive production, automatic transmission with torque converter, maximum two forward speeds. Full shift pattern mandatory. Mechanical lockup converters prohibited. Transmission brake permitted. Electric transbrake release system only. Maximum one transmission brake solenoid permitted. Automatic transmission flexplate meeting SFI Spec 29.1 mandatory. Aftermarket replacement transmission case, OEM replica, and accepted by NHRA, permitted. Overdrive/underdrive units prohibited. Pneumatic, electric, or other non-OEM automatic shifters prohibited. See General Regulations 2:14.

TRANSMISSION SHIELD

Transmission shield meeting SFI Spec 4.1 mandatory. Automatic transmission flexplate shield meeting SFI Spec 30.1 mandatory. See General Regulations 2:14.

BRAKES AND SUSPENSION: 3

BRAKES

Two rear-wheel hydraulic disc brakes mandatory. Hand brake, if used, must be located inside roll cage. See General Regulations 3:1.

STEERING

A device must be used to prevent long steering shaft from injuring driver in case of frontal impact. If removable steering wheel is used, commercially available quick-disconnect steering-wheel adapter meeting SFI Spec 42.1 mandatory. See General Regulations 3:3.

SUSPENSION

Rigid-mounted rear axles permitted. Rigid-mounted front axles permitted if wheelbase is 120 inches or more. Any front suspension using a beam or tubular axle must have radius rods attached to frame. Radius rods not mandatory on front axles rigidly mounted 18 inches or less from kingpin axis. See General Regulations 3:4.

WHEELIE BARS

Permitted. Wheels must be nonmetallic. See General Regulations 3:6.

FRAME: 4

BALLAST

Permitted. See General Regulations 4:2.

GROUND CLEARANCE

Minimum 3 inches from front of car to 12 inches behind centerline of front axle, 2 inches for remainder of car, except oil pan and exhaust headers.

PARACHUTE

Mandatory. See General Regulations 4:8.

PINION SUPPORT

Mandatory. See General Regulations 4:9.

ROLL CAGE

Mandatory. Chassis must be inspected every three years by NHRA and have serialized sticker affixed to frame before participation. Chassis must conform to SFI Spec 2.4.

Roll-cage padding meeting SFI Spec 45.1 mandatory anywhere driver's helmet may come in contact with roll-cage components. See General Regulations 4:4, 4:11, 10:6.

WHEELBASE & TREAD WIDTH

Minimum wheelbase 90 inches, maximum 225 inches. Maximum wheelbase variation from left to right: 2 inches. Minimum front tread width: 26 inches.

TIRES & WHEELS: 5

TIRES

Maximum width 12 inches as measured across tread surface or indicated by manufacturer on the sidewall. See General Regulations 5:1.

WHEELS

Lightweight automotive-type wire wheels permitted on front axle only, provided total car weight does not exceed 1,800 pounds, excluding driver. Maximum rear-wheel width: 12 inches. See General Regulations 5:2.

INTERIOR: 6

UPHOLSTERY

Optional.

BODY: 7

AIRFOIL

Side-mounted canard-type units permitted, maximum 400 square inches per side.

Canards may not extend more than 1 inch outside rear tire. Front wing must be below the top of the front tire and may not extend outside of front tires. Maximum wicker on canards and wings: .500-inch. No disguised aerodynamics permitted. Maximum front overhang 30 inches. Ground clearance must be 3 inches. See General Regulations 7:1.

BODY

Body and cowl must be metal, fiberglass, or carbon fiber and extend forward to firewall. Driver compartment, frame structure, roll bars, and body must be designed to prevent driver's body or limbs from making contact with wheels, tires, exhaust system, or track surface. If driver's body is in contact with belly pan, crossmember and subfloor

2026
Hot Rod Heritage Racing Series Rules Supplement

mandatory. Altered-type bodies prohibited. Driver's legs must be retained inside frame by subflooring or other retaining device that is independent of car's body.

FRONT-WHEEL FAIRINGS

Prohibited.

WINDSCREEN

Mandatory. See General Regulations 7:7.

ELECTRICAL: 8

BATTERIES

See General Regulations 8:1, 8:3, 8:4.

DELAY BOXES/DEVICES

Prohibited. See General Regulations 8:2, 8:8.

IGNITION

Single magneto or single coil ignition only. Mag advance or retard must be function of the driver. No rpm chip boxes allowed. See General Regulations 8:1, 8:3, 8:4, 8:5.

MASTER CUTOFF

Mandatory on all cars with a battery. See General Regulations 8:4.

SUPPORT GROUP: 9

COMPUTER/DATA RECORDERS

See General Regulations 9:1, 9:2.

FIRE EXTINGUISHER SYSTEM

Fire extinguishing system must meet SFI Spec 17.1. Minimum 5-pound, NHRA-accepted fire extinguishing system mandatory. System must be divided with one nozzle on driver's side and one nozzle on engine. See General Regulations 9:3.

TOW VEHICLES

Permitted. See General Regulations 9:10.

WARM-UPS

See General Regulations 9:4, 9:12.

DRIVER: 10

ARM RESTRAINTS

Mandatory. See General Regulations 10:3.

CREDENTIALS

Valid NHRA competition license mandatory. See General Regulations 10:4.

DRIVER

Any car with no crossmember above driver's legs must have a strap or device to prevent legs from projecting outside chassis.

DRIVER RESTRAINT SYSTEM

Three-inch driver restraint system meeting SFI Spec 16.1 mandatory. Restraint system must be updated at two-year intervals from date of manufacture. See General Regulations 10:5.

HEAD PROTECTOR

Mandatory. See General Regulations 10:6.

HELMET

2026
Hot Rod Heritage Racing Series Rules Supplement

Full-face helmet with shield meeting Snell: SA2015, SA2020, SA2025, or SFI: 31.1/2015, 31.1/2020, 41.1/2015, 41.1/2020 or FIA: 8860-2010, 8859-2015, 8860-2018, or 8859-2024 mandatory. See General Regulations 10:7.

**NECK COLLAR/HEAD AND NECK RESTRAINT
DEVICE/SYSTEM**

Neck collar meeting SFI Spec 3.3 mandatory in all cars running 9.99 (6.39*) or quicker or cars exceeding 135 mph. A head and neck restraint device/system may be used in lieu of a neck collar. See General Regulations 10:8.

Beginning Jan. 1, 2012, all drivers in the class will be required to wear a head and neck restraint device/system meeting SFI Spec 38.1.

PROTECTIVE CLOTHING

Jacket and pants meeting SFI Spec 3.2A/15, gloves 3.3/5, and boots/shoes 3.3/5 mandatory. Head sock or skirted helmet required if transmission is located in driver compartment. See General Regulations 10:10

**SECTION 6: PRO COMP (formally A/FUEL
ELIMINATOR)**

DESIGNATION

P/C, preceded by car number.

Reserved for supercharged, methanol-burning and injected nitromethane-burning front engine dragsters and center-steer altered and 1965 to 1979 Funny Cars. Cars are weighed at conclusion of run, including driver. Class limited to 550-cubic-inch maximum. Dragsters have a 1,925-pound minimum weight. Altered and Funny Cars have a minimum weight of 2,100 pounds. For dragsters using a Small Block Chevy engine (4.40" cylinder bore spacing and siamesed center exhaust head ports); the minimum weight is 1,475 pounds.

REQUIREMENTS & SPECIFICATIONS

ENGINE: 1

CYLINDER HEADS

Aftermarket alloy heads permitted.

ENGINE

Block may be cast or aluminum.

EXHAUST SYSTEM

Competition exhaust permitted. No collector-style headers allowed. Exhaust must be directed away from driver. See General Regulations 1:3.

FUEL SYSTEM

Fuel lines not permitted in driver's compartment. Fuel shutoff operable from the driver's seat mandatory. Fuel tank must be mounted above lower frame rail and must be equipped with a positive locking screw-on cap. Minimum temperature of fuel in the

2026
Hot Rod Heritage Racing Series Rules Supplement

staging lanes to the completion of the run and subsequent NHRA fuel check is 50 degrees F.

Blown Alcohol cars are limited to a maximum of one fuel pump, no overdrive. Fuel pump is restricted to a total fuel delivery of 10.60 gpm at 4,000 rpm pump speed measured at 100 psi.

Injected Nitro cars are limited to a maximum of one fuel pump, no overdrive. Fuel pump is restricted to a total fuel delivery of 10.60 gpm at 4,000 rpm pump speed measured at 100 psi.

Pump must be driven at 1/2 crankshaft speed. NHRA reserves the right to confiscate fuel pumps or uphold competitor(s) protest request regarding fuel pumps at any time during or after the event for further inspection. Down nozzles prohibited.

Maximum fuel-injector air-inlet opening: 65 square inches measured at butterfly or throttle bodies, excluding cross shaft in fully open position. Fuel-injector hat/scoops must be NHRA-accepted prior to competition. No composite materials (i.e., carbon fiber/Kevlar, graphite, etc.) can be used in injector hat and/or scoop. Hat/scoop must be nostalgic in appearance; internal modifications permitted. Scoops limited to 12 1/2 inches above throttle body as measured from centerline of throttle shaft to top of scoop. The use of electric, pneumatic, or any other automatic way of switching or sequencing of fuel system is prohibited. Fuel system must operate on its own pressure as far as adding or subtracting fuel volume. Manual high-speed fuel system permitted. The use of electrical/electronic timers to control pneumatic fuel system valves and/or electric fuel control solenoid valves is only permitted on supercharged alcohol altered combinations weighing a minimum of 2,100 pounds and having a 3-speed transmission. The fuel control system may use only movement of the throttle or clutch pedal, a transmission shift, electric/electronic timers, and/or an engine rpm switch to control the fuel-system valves and/or to start the timers that control the fuel-system valves. See General Regulations 1:6.

INJECTOR SCOOP

Scoop limited to 12 1/5 inches above throttle body as measured from centerline of throttle shaft to top of scoop. Air intake limited to 65 square inches. No composite materials in injector hat and/or scoop. Composite materials include but are not limited to carbon fiber, Kevlar, and weave-graphite fiber.

OIL RETENTION DEVICE

All vehicles must utilize an SFI Spec 7.1. The lower-engine-ballistic/restraint device must be specific for the oil pan and pump configuration being used and must fit according to the requirements of SFI Spec 7.1 and be used as appropriately designed for the specific application. See General Regulations 1:8.

SUPERCHARGER

Restricted to Roots-type supercharger for dragsters. Altered and Funny Car weighing a minimum of 2,100 pounds, may use a Screw-blower.

Roots-type rotor helix angle not to exceed that of standard 71-series GM-type rotor. High-helix rotors prohibited. Maximum size: 6-71, 17.250-inch case length, 15-inch rotor length; maximum rotor diameter: 5.840 inches including fixed stripping. Rotors must be driven from the front; both external drive and internal gearing.

2026
Hot Rod Heritage Racing Series Rules Supplement

Blower setback may not allow any portion of blower to extend behind bellhousing mounting surface on cylinder block. Spacer or components between top of supercharger case and bottom of fuel-injector hat restricted to 2-inch maximum. The case must be one piece with removable front and rear bearing end plates: Rotor must be contained within one-piece case. OEM manufacturer's cast or extruded billet blower case mandatory. No modifications to case as manufactured. Inlet shoes for inlet sizing permitted.

Manifold burst panel meeting SFI Spec 23.1, plus restraint system meeting SFI Spec 14.1 mandatory.

Maximum Roots supercharger overdrive is limited to 70.00 percent. Maximum Screw supercharger overdrive is limited to 40.00 percent.

Intercoolers prohibited on supercharged vehicles. Belt guard that protects all fuel, oil, and water lines required. Supercharger must be in a conventional location above the intake manifold and cylinder heads.

Manifolds are limited to a maximum manifold height of 8 inches as measured from valley gasket surface to blower mounting surface. Supercharger restraint device may not be modified. See General Regulations 1:10, 1:11.

THROTTLE

Throttle control must be manually operated by driver's foot: Electronics, pneumatics, hydraulics, or any other device may in no way affect the throttle operation. A mechanical device for controlling engine rpm during burnouts may be attached to the injector or throttle linkage but may not be driver-controlled. See General Regulations 1:12.

VALVE COVERS

Cast or fabricated metal valve covers using all attachment bolt holes mandatory. Valve cover gaskets, O-rings, etc. must be completely bonded/glued to either the valve cover or cylinder-head sealing surface. Vent tube adapters on the valve covers must either be fully welded to the valve covers or incorporate a gasket or O-ring that is bonded/glued to either the adapter or the valve cover. Valve covers must be fastened to the cylinder heads with studs and nuts in lieu of bolts where possible. Spark-plug tubes that penetrate the valve covers must have a restraining device to contain the spark-plug tube in the valve cover in the event the spark plug is discharged.

VENT-TUBE BREATHERS

NHRA-accepted catch-can/vent-tube system mandatory. Twist-on/quick-disconnect fittings between the vent-tube hoses and the valve-cover vent-tube adapters must incorporate a secondary locking device such as a hasp pin, ball lock pin, etc. Tape is not a satisfactory primary or secondary locking device. Double clamps are required on each end of all hoses used in the vent system, including the dry-sump vents. Minimum 1-inch-inside diameter hoses are required from each valve cover to the catch-can inlets and/or framerails and from each framerail outlet to both catch-can inlets. Minimum catch-can(s) capacity is an 8-quart sump. Catch cans must have adequate internal baffling. Minimum catch-can inlet configuration is one 1-inch-inside-diameter (or equivalent area) tubes. Minimum catch-can outlet/discharge configuration is one 1-inch-inside-diameter openings (or equivalent area). Vent tubes must be unobstructed from the interior of the valve cover to the interior of the catch can; i.e., no orifices, reduced areas, filler materials, etc. Pan/crankcase vacuum systems, of any description, are prohibited. See General Regulations 1:13.

DRIVETRAIN: 2

CLUTCH, FLYWHEEL, FLYWHEEL SHIELD

Flywheel and clutch meeting SFI Spec 1.4 and flywheel shield meeting SFI Spec 6.2 mandatory on all cars. Three discs maximum. Maximum depth of flywheel shield: 8-5/8 inches. Clutch must be manually operated by driver's foot: Electronics, pneumatics, hydraulics, or any other device may in no way affect the clutch system. Throwout bearing must release all fingers, levers, stages, etc. simultaneously. Staged or variable release clutches of any description prohibited. See General Regulations 2:3, 2:5, 2:6, 2:8.

DRIVELINE

A full cover of minimum .063-inch aluminum must enclose the driveline. Couplers mandatory. See General Regulations 2:1.

REAR END

Aftermarket full-floating or live axle assembly mandatory. Rear end must be secured with pinion support. See General Regulations 2:11.

TRANSMISSION

NHRA-accepted aftermarket automatic transmission or aftermarket planetary is limited to maximum two forward speeds (for Alterseds or Funny Cars equipped with a clutch, and weighing 2,100 lbs. minimum, three forward speeds allowed) and reverse permitted; when an approved aftermarket automatic transmission is used, an SFI Spec 30.1 flexplate shield, an SFI Spec 29.1 flexplate, and an SFI 4.1 transmission shield are mandatory.

When a planetary transmission is used with an aftermarket converter drive unit, the transmission must use an SFI Spec 4.1 transmission shield. The flexplate must be SFI Spec 29.1, and either an SFI Spec 30.1 flexplate shield or an SFI Spec 6.1, 6.2 or 6.3 flywheel shield are mandatory.

When an approved planetary transmission is used in conjunction with a clutch, the transmission must use an SFI Spec 4.1 transmission shield, and an SFI Spec 6.1, 6.2, or 6.3 flywheel shield is mandatory. All entries utilizing a converter must be equipped with a neutral safety switch and a reverse lockout.

Transmission brake permitted on all converter-equipped entries. (No delay allowed.)

Lockup converters and overdrive units are prohibited. A 1-to-1 relationship is mandatory in high gear for all transmission types.

Automated shifters and/or timer/rpm-type shifting devices prohibited; each individual shift must be a function of the driver. Shifting must be controlled by manual or pneumatic means only (driver pulls the lever or pushes the button); electronics may in no way affect the shifting mechanism.

BRAKES AND SUSPENSION: 3

BRAKES

Automated brakes prohibited: Application and release of brakes must be a function of the driver. Dual spots or equivalent oval pucks mandatory; minimum two rear-wheel hydraulic brakes. Hand brake, if used, must be located inside body or driver

2026
Hot Rod Heritage Racing Series Rules Supplement

compartment. Steel brake lines mandatory. Brake lines passing engine or blower drive must be shielded. See General Regulations 3:1.

STEERING

Commercially available quick-disconnect steering wheel meeting SFI Spec 42.1 or steering box crossmember mandatory. Use of a pinned steering crossmember in lieu of an SFI quick-disconnect steering wheel prohibited on front-engine cars. A device must be used to prevent a long steering shaft from injuring driver in case of frontal impact. See General Regulations 3:3.

SUSPENSION

Front suspension optional. See General Regulations 3:4.

WHEELIE BARS

Permitted. Wheels must be nonmetallic. See General Regulations 3:6.

FRAME: 4

BALLAST

Permitted. Maximum total ballast (welded or bolted), 250 pounds. See General Regulations 4:2.

GROUND CLEARANCE

Minimum 3 inches from front of car to 12 inches behind centerline of front axle, 2 inches for remainder of car, except oil pan.

PARACHUTE

Dual parachutes mandatory. Two separate shroud line mounting points mandatory. Beginning Pilot chutes must be made of a bright color, not black, to be visible on the racing surface if detached from the main chute. See General Regulations 4:8.

ROLL CAGE

Chassis must meet SFI Spec 10.1 or 10.2 (front-engine, driver in front of rear end) or SFI Spec 2.2 or 2.4 (front-engine, driver behind rear end). Plating of chassis prohibited; painting permitted. Chassis must be inspected yearly by NHRA and have serialized sticker affixed to frame before participation. Roll-cage padding meeting SFI Spec 45.1 mandatory where driver's helmet may come in contact with roll-cage components. Additional padding, mounted on flat stock and fastened to the roll cage on both sides of the driver's helmet, mandatory. Additional padding must be NHRA-accepted, securely mounted using bolts or locking fasteners, and must include a flame-retardant covering. A current list of NHRA-accepted lateral head supports is available on NHRARacer.com. All wiring must be external of the framerails; routing of cables, hydraulic, or pneumatic lines inside the chassis is permitted. Pressurization of framerails in lieu of air bottles is prohibited.

WHEELBASE

Maximum 225 inches.

TIRES & WHEELS: 5

TIRES

Tires must be specified for racing use by the manufacturer. Maximum tire width: 15

2026
Hot Rod Heritage Racing Series Rules Supplement

inches measured across the tread or as specified by the manufacturer.

WHEELS

Maximum width: 16 inches. Must be either beadlock design or use of a liner mandatory on non-beadlock wheels. Cars running 5.99 (*3.79) or quicker must use a SFI 15.3 drive wheel with either a liner or double bead lock. All wheels must bear a wheel conformance label indicating compliance with the SFI Certification it was originally built to. All 15.3 wheels must be recertified every 24 months.

INTERIOR: 6

UPHOLSTERY

Magnesium seats prohibited.

BODY: 7

BODY

Body and cowl must be metal, carbon fiber, or fiberglass. Driver compartment, frame structure, roll bars, and body must be designed to prevent driver's body or limbs from contact with track surface. Subflooring, inside but independent of body, mandatory where driver's legs rest on belly pan or chassis. Front overhang not to exceed 40 inches, measured from centerline of front spindle to forward most point of car. Ground effects of any description prohibited. Ground effects include but are not limited to rocker skirts, belly pans, sheet-metal work under the body that produces a "tunnel" for the passage of air, etc. Maximum overhang limit 40 inches.

BODY, FUNNY CAR

See Nostalgia Funny Car Section 7, Body: 7, Body

ESCAPE HATCH

See Nostalgia Funny Car Section 7, Body: 7, Escape Hatch

FIREWALL & FLOORS

See Nostalgia Funny Car Section 7, Body: 7, Firewall & Floors

SPOILER

See Nostalgia Funny Car Section 7, Body: 7, Spoiler

WINDSCREEN

Mandatory. See General Regulations 7:7.

WINGS/SUPPORTS

Maximum canard wing restricted to 400 square inches per side. Canards may not extend more than 1 inch outside rear tire. Front wing must be below front tire and may not extend outside of front tires. Total front-wing surface may not exceed 400 square inches. Maximum wicker on canards and wings: 1/2-inch. Canards and front wings, only aero surfaces allowed, except for altered, a wing restricted to 750 square inches is permitted. Adjustment of spoiler during run prohibited.

ELECTRICAL: 8

COMPUTERS

Computers prohibited.

DATA RECORDERS

Data recorders permitted. Cannot perform any function in fuel, clutch, or driver management.

IGNITION

Limited to single magneto, single point box, single crank trigger, single coil ignition only. Magneto system limited to a single 44-amp maximum. All external map or gauge

sensors that change timing prohibited. Magneto advance or retard devices must be driver-activated by mechanical, pneumatic, or electronic means; timers permitted. Maximum one spark plug per cylinder. Ignition system must be verified before competition. See General Regulations 8:1, 8:3, 8:4, 8:5.

SUPPORT GROUP: 9

FIRE EXTINGUISHER SYSTEM

Fire extinguisher system meeting SFI Spec 17.1 mandatory. A minimum 20-pound system required with a minimum one nozzle aimed at the driver and one at the front of the engine.

TOW VEHICLES

Permitted. See General Regulations 9:10.

WARM-UPS

See General Regulations 9:4, 9:12.

DRIVER: 10

ARM RESTRAINTS

Mandatory. See General Regulations 10:3.

CREDENTIALS

Valid NHRA competition license mandatory. See General Regulations 10:4.

DRIVER RESTRAINT SYSTEM

Driver restraint system meeting SFI Spec 16.1 or 16.5 mandatory. All belts must be covered with a fire-resistant covering. Restraint system must be updated at two-year intervals from date of manufacture. See General Regulations 10:5.

HELMET

Full-face helmet with shield meeting Snell: SA2015, SA2020, SA2025, or SFI: 31.1/2015, 31.1/2020 or FIA: 8860-2010, 8860-2015 or 8860-2018 mandatory. Eject Helmet Removal System (part number SDR 890-01-30) mandatory and must be installed per manufacturer instructions. A Stand 21 Lid Lifter head sock meeting SFI 3.3 may be used in lieu of the Eject Helmet Removal System. See General Regulations 10:7.

HEAD AND NECK RESTRAINT DEVICE/SYSTEM

At all times that the driver is in the race vehicle, from the ready line until the vehicle is on the return road, driver must properly utilize an SFI-approved head and neck restraint device/system, including connecting the helmet as required for full functionality of the device. The device/system must meet SFI Spec 38.1 and must display a valid SFI label. The head and neck restraint device/system, when connected, must conform to the manufacturer's mounting instructions, and it must be configured, maintained, and used in accordance with the manufacturer's instructions.

PROTECTIVE CLOTHING

Driver's suit must be one-piece, and must meet SFI Spec 3.2A/20. Long sleeve underwear shirt meeting SFI 3.3, long underwear pants meeting SFI 3.3, SFI Spec 3.3/20 gloves, glove under-liners made of flame retardant material, SFI Spec 3.3/20

boots, socks meeting SFI 3.3, SFI Spec 3.3 head sock, and SFI Spec 3.3/10 helmet skirt mandatory. All clothing containing metal or plastic prohibited. Undergarments that are worn in addition to those mandated that are made of flammable materials (e.g., nylon, rayon, polyester, spandex etc.) are prohibited. All jewelry prohibited. All jacket and pants or driver suit that meet the SFI Spec 3.2A/20 must be recertified on a five-year interval. See General Regulations 10:10

SECTION 7: NOSTALGIA FUNNY CAR

DESIGNATION

N/FC, preceded by number.

Reserved for 1984 and older American bodies, nitro-burning Funny Cars built specifically for all-out drag racing competition. Minimum weight at conclusion of run: 2,300 pounds, including driver.

These rules are the minimum standards for operation of an Alternative Sanctioning Organization using NHRA member tracks or the standard an NHRA member track must use when booking in this type of exhibition show.

Alternative Sanctioning Organizations must employ at least one silver-certified SFI tech inspector throughout the event. Proper tech inspection and follow-through during the entire event is imperative.

Speeds of 250 mph and/or elapsed times in the 5.90-second range will require a reevaluation of performance restrictions. True nostalgia cars that do not meet these rules may be certified for exhibition runs only through the NHRA main office on an individual basis.

REQUIREMENTS & SPECIFICATIONS

ENGINE: 1

ENGINE

Any internal-combustion, American-made OEM-type engine permitted. Maximum cubic inches 500; maximum Hemi bore center spacing 4.840 inches, maximum Ford bore spacing 4.900 inches, must maintain bore centers +/- .015-inch from stock. Blocks and cylinder heads must retain all physical characteristics of stock-production components. Billet blocks permitted. Any new block design must be submitted to NHRA Technical Services Department for acceptance. Alloy and billet heads allowed. Accepted billet heads and block must remain as manufactured. Machining of billet heads or billet blocks to reduce weight is prohibited. OEM cylinder-head bolt pattern mandatory for all cylinder-head types. Cylinder heads must retain stock OEM-valve angles.

LOWER CONTAINMENT

Engine must be equipped with an SFI Spec 7.1 lower-engine-ballistic/restraint device. In addition, an engine oil-retention pan mandatory; minimum material .050-inch aluminum or .040-inch carbon fiber/Kevlar. Pan must extend from framerail to framerail and extend

from the rear motorplate to minimum 1 inch forward of the front face of the lower pulley and must incorporate minimum 4-inch-high vertical folded-up walls on the sides and minimum 2 inches on front and rear. Front and rear walls must be “coved” toward oil pan to assist oil in staying within the confines of the oil-retention pan. Pan must be either a one-piece design or constructed as to be sealed as a retention device to retain oil. Minimum number of slots or holes in the walls to clear frame, steering, or lines permitted. A nonflammable, oil-absorbent liner mandatory inside of retention device.

EXHAUST SYSTEM

Double-pipe insulated exhaust headers mandatory. Double tube must extend to start of bend at bottom of body. See General Regulations 1:3.

FUEL

Nitromethane and methanol permitted. All other fuels prohibited.

FUEL SYSTEM

Single fuel pump mandatory. Fuel pump must be NHRA accepted. NHRA-accepted fuel pumps: Earp Machinery NOSTF [or AP1.7-.95](#), Enderle 1100 [or SG2-1250](#), Settles [Nitro Georotor](#), Aeromotive 11936 [or 11966](#), Waterman 320950N [or 320950](#), Rage Racing 1400N-FC, Hard Parts LLC 175x1.1x (David Benjamin), [Alchemy Engineering AE950NFC](#). All new fuel pumps must be submitted to NHRA for acceptance. Fuel pumps must retain as-manufactured gear or rotor outside diameter, depth, and tooth/lobe count. Fuel pumps with a second outlet must have one of the outlets capped or routed back to the fuel tank or return system. Fuel pump restricted to a total fuel delivery limited to 21.0 gpm at 4,000 rpm pump speed measured through a 0.300-inch orifice. All pumps must be sealed by [Scott Hall of Ally Racing Services](#) or the NHRA. Fuel pump gear sets will be randomly measured with a certified “GO-NO GO” gauge per the approved fuel pump manufacture measurements. Modification to an approved fuel pump is strictly prohibited. In addition, fuel pumps may be selected and sent back to [Scott Hall of Ally Racing Services](#) for verification, at the NHRA’s sole and absolute discretion. Pump must be driven at 1/2 crankshaft speed. NHRA reserves the right to confiscate fuel pumps or uphold competitor protest request regarding fuel pumps at any time during or after the event for further inspection. No electronic, pneumatic, or hydraulic controls of fuel system. Fuel system changes must be a function of the driver by mechanical means only. One action by the driver can only result in one function, one time, other than fuel pressure operated check valves (i.e., you may not incorporate a system through a driver-activated switch or lever, or a wide-open throttle switch, that starts a series of events). Fuel shutoff must be operable from the driver’s seat.

No pressurized fuel tanks. Fuel tanks must be mounted above the lower framerail. Fuel tank and fuel lines must be within the confines of the frame and be protected from coming in contact with the track surface. Fuel lines in the driver’s compartment prohibited except for a fuel-pressure gauge; lines must be steel or steel-braided with steel fittings. All flexible fuel-pressure lines, with the exception of the hat nozzle lines, must be pressure-tested and labeled. All testing must be hydrostatic for minimum 30 seconds at 750psi. Label must indicate date, PSI, and tester ID. Labeling must be impervious to nitromethane and brake clean. Must have fuel shutoff operable from the driver’s seat. Fuel tank must be equipped with a positive locking screw-on cap.

2026
Hot Rod Heritage Racing Series Rules Supplement

Maximum number of nozzles 24 (maximum 8 in injector hat, 16 in manifold). Y-nozzles may be used in lieu of individual nozzles in the manifold; limited to 16 nozzle jets. Down nozzles prohibited. Maximum fuel injector air inlet opening: 45 square inches measured at butterfly or throttle bodies, excluding cross shaft in fully open position. Fuel injector hat/scoops must be NHRA accepted prior to competition. No composite materials (i.e., carbon fiber/Kevlar, graphite, etc.) can be used in injector hat and/or scoop. Hat/scoop must be nostalgic in appearance, internal modifications allowed. Scoops limited to 12 1/2 inches above throttle body as measured from centerline of throttle shaft to top of scoop. The use of electric, pneumatic, or any other automatic way of switching or sequencing of fuel system is prohibited. Fuel system must operate on its own pressure as far as adding or subtracting fuel volume. Manual high-speed fuel system allowed. See General Regulations 1:5 and 1:6.

NITROUS OXIDE

Prohibited.

OIL LINES

All flexible-pressure oil lines, excluding return lines and any line 30psi or lower in pressure, must be pressure-tested and labeled. All testing must be hydrostatic for minimum 30 seconds at 750psi. Label must indicate date, PSI, and tester ID. Labeling must be impervious to nitromethane and brake clean. Otherwise hard line mandatory.

PAN PRESSURE SHUTOFF SYSTEM

An Electrimation Nostalgia Pan Pressure Shutoff System Kit is mandatory on all cars. All of these components must be properly installed per the manufacturer's instructions and fully operational. Maximum setting for the pan pressure switch is 9 PSI. Any attempt to circumvent the function of any of these devices is strictly prohibited.

SUPERCHARGER

Restricted to Roots-type supercharger; rotor helix angle not to exceed that of standard 71-series GM-type rotor. High-helix prohibited. OEM manufacturer's cast or extruded billet blower case mandatory. Limited to a single, Roots-type 6.71 blower. Specification limits: 15-inch rotor length, 18.250-inch case length, and 5.840-inch rotor cavity diameter. Rotors must be driven from the front; both external drive and internal gearing. Rotor helix angle limited to standard 71 series GM-type rotor (60 degrees). Maximum overdrive: 18.99 percent. Blower setback may not allow any portion of blower to extend behind bellhousing mounting surface on cylinder block. Spacer or components between top of supercharger case and bottom of fuel injector hat restricted to 2-inch maximum. Supercharger restraint system meeting SFI Spec 14.3 mandatory. Aluminum studs required. Manifold burst panel meeting SFI Spec 23.1 mandatory. Manifolds are limited to a maximum manifold height of 8 inches as measured from valley gasket surface to blower mounting surface. Supercharger belt guard mandatory. Fuel and/or oil lines must be shielded wherever they pass the supercharger drive belt. Either a belt guard or fuel/oil line guard permitted. Turbochargers, screw-type superchargers, and centrifugal-type superchargers prohibited. See General Regulations 1:10, 1:11.

THROTTLE

Throttle control must be manually operated by driver's foot; electronics, pneumatics, hydraulics, or any other device may in no way affect the throttle operation. Throttle must incorporate a positive-action return system. See General Regulations 1:12.

VALVE COVERS

2026
Hot Rod Heritage Racing Series Rules Supplement

Cast or fabricated metal valve covers using all attachment bolts mandatory. Carbon fiber/composite valve covers prohibited.

VENT-TUBE BREATHERS

Vent tubes must be double clamped at each connection. Minimum diameter, 1 ¼ inches for all breather tubes. All quick connections in the system must have a secondary locking system (tape, wire ties, etc. not allowed). Minimum catch-can(s) capacity is an 8-quart sump. Catch can(s) must have adequate internal baffling to prevent oil from being deposited on racing surface. NHRA-accepted vent tubes/hoses are mandatory for all connections; see NHRARacer.com for a list of accepted vent tubes/hoses. See General Regulations 1:13.

DRIVETRAIN: 2

CLUTCH, FLYWHEEL, FLYWHEEL SHIELD

Flywheel and clutch meeting SFI Spec 1.3 or 1.4 and flywheel shield meeting SFI Spec 6.2 mandatory. Clutch management system prohibited. Maximum number of discs three, maximum number of fingers six. Release of clutch must be the result of a manual operation by the driver's foot. No staged systems allowed. Clutch exhaust filter mandatory. See General Regulations 2:3, 2:5, 2:6, 2:8.

DRIVELINE COVER

Driveline must be covered in .024-inch steel or .0625-inch aluminum 360-degree full cover. Couplers mandatory. Rear cover must surround the coupler. Front cover must surround the driveshaft from the back of the reverser to the end of the splicer sleeve in the area of the driver's leg. All covers must be securely mounted to frame, either by a suitable crossmember or third member.

REAR END

Rear-end gear ratio minimum (numeric) 3.90:1. Aftermarket full-floating or live axle assembly mandatory. See General Regulations 2:11.

TRANSMISSION

Two-speed transmission and reverser required. Transmission must be planetary-type design. OEM or Powerglide-type units prohibited. A ballistic shield covering all units mandatory; must meet SFI Spec 4.1. See General Regulations 2:13, 9:7.

BRAKES AND SUSPENSION: 3

BRAKES

Four-wheel hydraulic brakes mandatory. Application and release of brakes must be a function of the driver; electronics, pneumatics, or any other device may in no way affect or assist brake operation. Hand brake, if used, must be located inside body or driver compartment. Carbon-fiber brake rotors used in conjunction with carbon-fiber specific brake pads mandatory on rear wheels. Carbon-fiber brake rotors used in conjunction with carbon-fiber-specific brake pads mandatory on the front wheels of any car that runs 240 mph or faster. Once a car completes a run at or above 240 mph, carbon-fiber brake rotors with carbon-fiber-specific brake pads must be installed on the car before it can make another run. Steel brake lines mandatory. NHRA-accepted fireproof brake-line covering mandatory on all (front and rear) flexible connection lines; see NHRARacer.com for a list of accepted manufacturers. See General Regulations 3:11.

2026
Hot Rod Heritage Racing Series Rules Supplement

STEERING

Conventional automotive-type rod ends must be a minimum of 3/8-inch shank diameter and must be installed with washers to prevent bearing pullout. Removable steering wheel, if used, must meet SFI Spec 42.1.

FRAME: 4

BALLAST

Permitted. Must be secured with minimum of two 3/8-inch, Grade 8 fasteners, per 100 pounds.

GROUND CLEARANCE

Minimum 3 inches from front of car to 12 inches behind centerline of axle; 2 inches for the remainder of the car, except oil pan and headers.

PARACHUTE

Dual parachutes mandatory. Two separate shroud-line mounting points mandatory with sleeved 1/2-inch-minimum Grade 8 steel bolts with self-locking nuts or with nuts welded onto parachute brackets. Shroud-line mounting brackets must be constructed of minimum 3/16-inch 4130 steel. Fire-resistant protective covers must be on all parachute packs and unpacked shroud lines. Beginning January 1, 2022, pilot chutes must be made of a bright color, not black, to be visible on the racing surface if detached from the main chute. See General Regulations 4:8.

Two NHRA-accepted parachute tethers are required and must be routed through each shroud line end loop and be attached using the rear end mounting bolts on each side. The mounting attachments on each end of both tethers must attach to either separate rear end mounting bolts or opposite ends of a single bolt (one under the head of the bolt and the other under the nut). NHRA-accepted parachute tethers: Amick Race Car Restraints PARA-101REV1, Future Fibres FF30MLB-P-MB, or Taylor Motorsports 108. When Future Fibres FF30MLB-P-MB is used, only one tether is required and must be routed through each shroud line end loop and be attached using the rear end mounting bolt on each side. All tethers must be covered with a fire-resistant material.

ROLL CAGE

Chassis must have manufacturer's name, serial number, and date of manufacture. Chassis must meet SFI Spec 10.1. Plating of chassis prohibited; painting permitted. Chassis must be inspected yearly by NHRA and have serialized sticker affixed to frame before participation. Roll-cage padding meeting SFI Spec 45.1 mandatory where driver's helmet may come in contact with roll-cage components. Additional padding, mounted on flat stock and fastened to the roll cage on both sides of the driver's helmet, mandatory. Additional padding must be NHRA-accepted, securely mounted using bolts or locking fasteners, and must include a flame-retardant covering. A current list of NHRA-accepted lateral head supports is available on NHRARacer.com. Pressurization of framerails in lieu of air bottles is prohibited.

SUSPENSION

Rigid rear suspension mandatory. Front suspension optional.

WHEELBASE

Minimum: 118 inches; maximum: 125 inches, measured on long side. Maximum wheelbase variation from left to right: 2 inches.

TIRES & WHEELS: 5

TIRES

Race-only spec tires on front mandatory. Size of rear tires limited to 34.6-inch diameter x 17-inch wide.

WHEELS

Must be either beadlock design or use of a liner mandatory on non-beadlock wheels.

Beginning January 1, 2023, cars running 5.99 (*3.79) or quicker must use a SFI 15.3 drive wheel with either a liner or double bead lock. All wheels must bear a wheel conformance label indicating compliance with the SFI Certification it was originally built to. All 15.3 wheels must be recertified every 24 months.

INTERIOR: 6

SHEET METAL

Driver-compartment interior, firewall, seat, etc. must be aluminum or steel. Magnesium or carbon fiber prohibited.

UPHOLSTERY

Seats must be foamed with energy-absorbing material and formed to the driver's body. Minimum one-layer, flame-retardant-material mandatory as seat upholstery.

BODY: 7

BODY

Limited to 1965 to 1979 American-made bodies. Bodies must resemble the original mass-produced make and model. Corvette roadster and Jeep bodies permitted. Bodies may be made of fiberglass or composite material. Body must lift off as a one-piece unit. Minimum body width is 60 inches, measured at the centerline of the front and rear axle. Maximum lowering of roof height: 2 inches. Front fender bubbles allowed, maximum 2 1/2 inches. The body may be shortened or lengthened a maximum of 15 percent of original dimensions. Opening for blower hat must have a minimum 2.500-inch clearance between body and throttle linkage. Injector box in windshield cannot exceed 50 percent of windshield height. Any modifications to body not described are prohibited. Side windows prohibited. Side windows are the windows that would be where a front door would be in the stock vehicle being used. Exception: Vent windows permitted, may not extend 2 inches rearward where the A-pillar meets the roof line. Window must be perpendicular to the bottom of the side window frame. The 2 inches will be measured from the rearmost part of the upper curve of the circumference where the A-pillar meets the roof. The vent window must be flat. It cannot be formed to deflect air inward or outward. Rear Quarter Windows: Rear quarter window is where that window would be in the stock production vehicle being used. That window cannot extend forward of where the rear of the forward door opening would be. The rear quarter window may be solid (part of the body mold) or clear. But must be flat. And fit against the outside of the body. No part of the window can be formed to deflect air inward or outward. Diverting Air: Any device that diverts air into or out from the car's body or forms a flat lip that could be used for pushing down the body is prohibited. With regard to lips around the bottom of a body, that lip can be a maximum of 1 inch. Body (hood) burst panel, minimum 288

2026
Hot Rod Heritage Racing Series Rules Supplement

square inches, mandatory. Body burst panel must be secured with plastic screws and two 1/8-inch stainless-steel wires, with body pad bolted with plate on both sides of panel. Fireproof body undercoat required, with manufacturer's sticker required on the body. All new bodies or changes being made on current bodies that are intended for use in the NHRA Hot Rod Heritage Racing Series N/FC class must be submitted for acceptance to the NHRA National Technical Director.

ESCAPE HATCH

A working escape hatch must be installed in top of body to permit easy driver exit; see-through types prohibited. Minimum size, 18 inches x 17 inches. Roof hatch must be permanently attached and hinged at front. Must have release mechanism, operable from both inside and outside of car.

FIREWALL & FLOORS

Must be constructed of .032-inch aluminum or .024-inch steel. Firewall must completely seal driver from engine compartment per specification for the Funny Car section of the NHRA Rulebook. Magnesium prohibited.

SPOILER

Rear spoiler limited to roof height and body width (modern-type spoilers or spill plates prohibited). Spill plates may not extend forward of the bottom of the rear window or extend past the trailing edge of the rear deck lid. Spill plates cannot be above the roof line. Front spoiler limited to overall overhang measurement of 40 inches, measured from the centerline of the forwardmost front spindle. If the front overhang of a selected body is less than 40 inches, an extension may be added to reach a maximum of 40 inches, measured from the centerline of the forwardmost front spindle. The front and rear spoilers are the only aerodynamic devices permitted; any other wings, spoilers, or canards prohibited.

ELECTRICAL: 8

COMPUTERS

Computers prohibited.

DATA RECORDERS

Data recorders permitted. Cannot perform any function in fuel, clutch, or driver management.

IGNITION

Single Magneto System Permitted:

- One Point style magneto with one single coil
- One Electronic MSD 4.0 inch diameter body magneto generator
- One MSD points box & MSD coil
- MSD Part Numbers: 8142 Red Coil, 8145 Red Point Box or MSD Part Numbers: 81423 Black Coil, 81453 Black Point Box

No amperage upgrades can be done to both the point and electronic style magnetos. Only commercially available 44 Amp magneto permitted, must not exceed manufacturers rated output. MSD 4 inch diameter body generators permitted. Rotation changes cap size and magneto drive adapter can be changed to adapt to different magneto drives and engine combinations.

2026
Hot Rod Heritage Racing Series Rules Supplement

Crank triggers, traction control devices and MSD Grids prohibited. Battery connection between magneto generator and MSD points box prohibited.

Timing retard must be a function of the driver by mechanical or pneumatic means only.

A functional positive action, ignition ON/OFF switch located in the driver's compartment capable of de-energizing the entire system is mandatory. Driver must be able to easily access and operate the ignition ON/OFF when seated in a normal driving position while seat belts are secured. Momentary contact with prohibited. The ignition ON/OFF switch is to be used to shut off the engine if the fuel shutoff does not function properly.

SUPPORT GROUP: 9

FIRE SYSTEM

Fire extinguishing system must meet SFI Spec 17.1. Minimum 20-pound or more fire extinguishing system mandatory. System must be divided so that a minimum of 15 pounds is directed into engine compartment by means of nozzled outlets placed in front of each bank of exhaust headers. Remaining 5 pounds or more should be dispersed in driver compartment by means of an atomizing nozzle placed at driver's feet. Must be installed per manufacturer's specifications. Fire-bottle activation cables must be installed inside framerail where cable passes engine/bellhousing area. Carbon-fiber bottles prohibited. See General Regulations 9:3.

JACKS AND JACK STANDS

No work may be done under any car in the pits while supported by a jack. No car may be fired while on a jack. Jack stands are required while work is performed or while car is being warmed up; a licensed driver must be in the seat anytime the motor is being run. Jack-stand devices must provide a minimum ground clearance of 7 inches from bottom of rear tire to ground while car is running.

SHUTOFF DEVICE

Properly installed and operational Electrimotion Nostalgia Shutoff Controller Kit (part number SB003) mandatory. The Electrimotion Nostalgia Shutoff Controller Kit must be installed per manufacturer's instructions. Beginning July 1, 2018 the Electrimotion Shutoff Receiver (part number RF001) is mandatory. Modification of or tampering with the Electrimotion Nostalgia Shutoff Controller Kit is prohibited. The Electrimotion Crew Alert Box, part number CB001, may be used in conjunction with the Shutoff Device to illuminate a dash light for driver notification, disengage throttle and /or enable the shutoff device. Any other use of the Crew Alert box is prohibited.

WARM-UPS

When starting vehicle in the pit area, vehicle must be fully within the confines of the assigned space. No part of the car may extend past the trailer. See General Regulations 9:4, 8:12.

DRIVER: 10

ARM RESTRAINTS

Mandatory. See General Regulations 10:3.

CREDENTIALS

2026
Hot Rod Heritage Racing Series Rules Supplement

Valid Nostalgia Funny Car or equivalent license mandatory. See General Regulations 10:4.

DRIVER RESTRAINT SYSTEM

Minimum 6-point, driver restraint system meeting SFI Spec 16.1 or 16.5 mandatory. All belts and mounting points must be covered with a fire-resistant material. Restraint system must be updated at two-year intervals from date of manufacture. See General Regulations 10:5.

HELMET

Full-face helmet with shield meeting Snell: SA2015, SA2020, SA2025, or SFI: 31.1/2015 or 31.1/2020 or FIA: 8860-2010, 8859-2015, 8860-2018, or 8859-2024 mandatory. Helmet must meet applicable SFI, Snell or FIA specs with fresh air system installed. Compressed air only. Air can be supplied on demand or by constant pressure. Beginning January 1, 2022, Eject Helmet Removal System (part number SDR 890-01-30) mandatory and must be installed per manufacturer instructions. A Stand 21 Lid Lifter head sock meeting SFI 3.3 may be used in lieu of the Eject Helmet Removal System. See General Regulations 10:7.

HEAD AND NECK RESTRAINT DEVICE/SYSTEM

At all times that the driver is in the race vehicle, from the ready line until the vehicle is on the return road, driver must properly utilize an SFI-approved head and neck restraint device/system, including connecting the helmet as required for full functionality of the device. The device/system must meet SFI Spec 38.1 and must display a valid SFI label. The head and neck restraint device/system, when connected, must conform to the manufacturer's mounting instructions, and it must be configured, maintained, and used in accordance with the manufacturer's instructions.

PROTECTIVE CLOTHING

Driver's one-piece suit meeting SFI Spec 3.2A/20, long sleeve underwear shirt meeting SFI 3.3, long underwear pants meeting SFI 3.3, SFI Spec 3.3/20 gloves, glove underliners made of flame retardant material, SFI Spec 3.3/20 boots, socks meeting SFI 3.3, SFI Spec 3.3 head sock, and SFI Spec 3.3/10 helmet skirt mandatory. All clothing containing metal or plastic prohibited. Undergarments that are worn in addition to those mandated that are made of flammable materials (e.g., nylon, rayon, polyester, spandex etc.) are prohibited. All jewelry prohibited. All jackets and pants or driver suit that meet the SFI Spec 3.2A/20 must be recertified on a five-year interval. See General Regulations 10:10.

SECTION 8: NOSTALGIA TOP FUEL

DESIGNATION

N/TF, preceded by number.

Reserved for front-engine supercharged, nitro-burning dragsters built specifically for all-out drag racing competition.

These rules are the minimum standards for operation of an Alternative Sanctioning Organization using NHRA member tracks or the standard an

NHRA member track must use when booking in this type of exhibition show.

Alternative Sanctioning Organizations must employ at least one silver-certified SFI tech inspector throughout the event. Proper tech inspection and follow-through during the entire event is imperative. Speeds of 260 mph and/or elapsed times in the mid-five-second range will require a reevaluation of performance restrictions.

True nostalgia cars that do not meet these rules may be certified for exhibition runs only through the NHRA main office on an individual basis.

REQUIREMENTS & SPECIFICATIONS

ENGINE: 1

ENGINE

Any internal-combustion, American-made OEM-type engine permitted. Maximum cubic inches 470; Minimum weight per cubic inch 4.60; maximum Hemi bore center spacing 4.840 inches, maximum Ford bore spacing 4.900 inches, must maintain bore centers +/- .015-inch from stock. Blocks and cylinder heads must retain all physical characteristics of stock-production components. Billet blocks permitted. Any new block design must be submitted to NHRA Technical Services Department for acceptance. Machining of billet blocks to reduce weight is prohibited. Alloy and billet heads permitted. Accepted billet heads and block must remain as manufactured. OEM cylinder-head bolt pattern mandatory for all cylinder-head types. Cylinder heads must retain stock OEM-valve angles.

LOWER CONTAINMENT

Engine must be equipped with an SFI Spec 7.1 lower-engine-ballistic/restraint device. In addition, an engine oil-retention pan mandatory; minimum material .050-inch aluminum or .040-inch carbon fiber/Kevlar. Pan must extend from framerail to framerail and extend from the rear motorplate to minimum 1 inch forward of the front face of the lower pulley and must incorporate minimum 4-inch-high vertical folded-up walls on sides and minimum 2 inches on front and rear. Front and rear walls must be "coved" toward oil pan to assist oil in staying within the confines of the oil-retention pan. Pan must be either a one-piece design or constructed as to be sealed as a retention device to retain oil. Minimum number of slots or holes in the walls to clear frame, steering, or lines permitted. A nonflammable, oil-absorbent liner mandatory inside of retention device.

EXHAUST SYSTEM

Exhaust must be directed away from driver.

FUEL

Nitromethane and methanol permitted. All other fuels prohibited.

FUEL SYSTEM

Single fuel pump mandatory. Fuel pump must be NHRA accepted. NHRA-accepted fuel pumps: Earp Machinery NOSTF or AP1.7-.90, Enderle 1100 or SG2-1190, Hilborn -4,

Settles Nostalgia [Georotor](#), Aeromotive 11937 or 11967, Waterman 320900N, Rage Racing 1400N, Hard Parts LLC 175x1.0x (David Benjamin), [Alchemy Engineering AE900NTF](#). All new fuel pumps must be submitted to NHRA for acceptance. Fuel pumps must retain as-manufactured gear or rotor outside diameter, depth, and tooth/lobe count. Fuel pumps with a second outlet must have one of the outlets capped or routed back to the fuel tank or return system. Fuel pump restricted to a total fuel delivery limited to 20.0 gpm at 4,000 rpm pump speed measured through a 0.300-inch orifice. All pumps must be sealed by [Scott Hall of Ally Racing Services](#) or the NHRA. Fuel pump gear sets will be randomly measured with a certified "GO-NO GO" gauge per the approved fuel pump manufacture measurements. Modification to an approved fuel pump is strictly prohibited. In addition, fuel pumps may be selected and sent back to [Scott Hall of Ally Racing Services](#) for verification, at the NHRA's sole and absolute discretion. Pump must be driven at 1/2 crankshaft speed. NHRA reserves the right to confiscate fuel pumps or uphold competitor protest request regarding fuel pumps at any time during or after the event for further inspection. No electronic, pneumatic, or hydraulic controls of fuel system. Fuel system changes must be a function of the driver by mechanical means only. One action by the driver can only result in one function, one time, other than fuel pressure operated check valves (i.e., you may not incorporate a system through a driver-activated switch or lever, or a wide-open throttle switch, that starts a series of events). Fuel shutoff must be operable from the driver's seat.

No pressurized fuel tanks. Fuel tanks must be mounted above the lower framerail. Fuel tank and fuel lines must be within the confines of the frame and be protected from coming in contact with the track surface. Fuel tank must have a positive locking screw-on cap. Fuel line must be isolated from driver's compartment. Fuel-gauge lines in the driver's compartment must be steel-braided with steel fittings. All flexible fuel-pressure lines, with the exception of the hat nozzle lines, must be pressure-tested and labeled. All testing must be hydrostatic for minimum 30 seconds at 750psi. Label must indicate date, PSI, and tester ID. Labeling must be impervious to nitromethane and brake clean.

Maximum number of nozzles 24 (maximum 8 in injector hat, 16 in manifold). Y-nozzles may be used in lieu of individual nozzles in the manifold; limited to 16 nozzle jets. No down nozzles allowed. Maximum fuel injector air inlet opening: 65 square inches measured at butterfly or throttle bodies, excluding cross shaft in fully open position. Fuel injector hat/scoops must be NHRA accepted prior to competition. No composite materials (i.e., carbon fiber/Kevlar, graphite, etc.) can be used in injector hat and/or scoop. Internal modifications to scoop or hat allowed. See General Regulations 1:5 and 1:6.

OIL LINES

All flexible-pressure oil lines, excluding return lines and any line 30psi or lower in pressure, must be pressure-tested and labeled. All testing must be hydrostatic for minimum 30 seconds at 750psi. Label must indicate date, PSI, and tester ID. Labeling must be impervious to nitromethane and brake clean. Otherwise hard line mandatory.

PAN PRESSURE SHUTOFF SYSTEM

An Electrimation Nostalgia Pan Pressure Shutoff System Kit is mandatory on all cars. All of these components must be properly installed per the manufacturer's instructions

and fully operational. Maximum setting for the pan pressure switch is 9 PSI. Any attempt to circumvent the function of any of these devices is strictly prohibited.

SUPERCHARGER

Restricted to Roots-type supercharger; rotor helix angle not to exceed that of standard 71-series GM-type rotor. High-helix prohibited. OEM manufacturer's cast or extruded billet blower case mandatory. Maximum size: 6-71, 18.250-inch case length. Maximum rotor length: 15 inches. Maximum rotor cavity diameter: 5.840 inches. Maximum overdrive: 14.99 percent. Rotors must be driven from the front; both external drive and internal gearing. Blower setback may not allow any portion of blower to extend behind bellhousing mounting surface on cylinder block. Spacer or components between top of supercharger case and bottom of fuel injector hat restricted to 2-inch maximum. Supercharger restraint system meeting SFI Spec 14.3 mandatory. Aluminum studs required. Manifold burst panel meeting SFI Spec 23.1 mandatory. Manifolds are limited to a maximum manifold height of 8 inches as measured from valley gasket surface to blower mounting surface. Supercharger belt guard mandatory. Fuel and/or oil lines must be shielded wherever they pass the supercharger drive belt. Either a belt guard or fuel/oil line guard permitted. Turbochargers, screw-type superchargers, and centrifugal-type superchargers prohibited. See General Regulations 1:11.

THROTTLE

Throttle control must be manually operated by driver's foot; electronics, pneumatics, hydraulics, or any other device may in no way affect the throttle operation. Throttle must incorporate a positive-action return system. See General Regulations 1:12.

VALVE COVERS

Cast or fabricated metal valve covers using all attachment bolts mandatory. Carbon fiber/composite valve covers prohibited. Must be NHRA-accepted.

VENT-TUBE BREATHERS

Vent tubes must be double clamped at each connection. Minimum diameter, 1 ¼ inches for all breather tubes. All quick connections in the system must have a secondary locking system (tape, wire ties, etc. not allowed). Minimum catch-can(s) capacity is an 8-quart sump. Catch can(s) must have adequate internal baffling to prevent oil from being deposited on racing surface. NHRA-accepted vent tubes/hoses are mandatory for all connections; see NHRARacer.com for a list of accepted vent tubes/hoses. See General Regulations 1:13.

DRIVETRAIN: 2

CLUTCH, FLYWHEEL, FLYWHEEL SHIELD

Flywheel and clutch meeting SFI Spec 1.3 or 1.4 and flywheel shield meeting SFI Spec 6.2 mandatory. Clutch management system prohibited. Maximum number of discs three, maximum number of fingers six. Release of clutch must be the result of a manual operation by the driver's foot. No staged systems allowed. Clutch exhaust filter mandatory. See General Regulations 2:3, 2:5, 2:6, 2:8.

DRIVELINE COVER

Driveline must be covered in .0625-inch steel or aluminum 360-degree full cover. Couplers mandatory. All covers must be securely mounted to frame, either by a suitable crossmember or third member. See General Regulations 2:1.

REAR END

2026
Hot Rod Heritage Racing Series Rules Supplement

Rear-end gear ratio limited to 3.90:1 (ratio numerically lower than 3.90:1; prohibited). Aftermarket full-floating or live axle assembly mandatory. See General Regulations 2:11.

TRANSMISSION

Direct drive or two-speed transmission permitted. Two-speed transmission must be planetary-type design. OEM or Powerglide-type units prohibited. A ballistic shield covering all two-speed transmission units mandatory; must meet SFI Spec 4.1. A two-speed transmission may only be used in conjunction with a points-type magneto. Reverser mandatory. See General Regulations 2.13, 9:7.

REVERSER SHIELD

A one-piece ballistic shield covering all units mandatory. Must meet SFI Spec 4.1. See General Regulations 2:13.

BRAKES AND SUSPENSION: 3

BRAKES

Dual piston hydraulic rear wheel brakes mandatory. Application and release of brakes must be a function of the driver; electronics, pneumatics, or any other device may in no way affect or assist brake operation. Hand brake, if used, must be located inside body or driver compartment. Carbon-fiber brake rotors used in conjunction with carbon-fiber specific brake pads mandatory; all other materials prohibited. Steel brake lines mandatory. NHRA-accepted fireproof brake-line covering mandatory on all flexible connection lines; see NHRARacer.com for a list of accepted manufacturers. See General Regulations 3:11.

STEERING

Conventional automotive-type rod ends must be a minimum of 3/8-inch shank diameter and must be installed with washers to prevent bearing pullout. Removable steering wheel, if used, must meet SFI Spec 42.1. See General Regulations 3:3.

FRAME: 4

BALLAST

Permitted. Must be secured with minimum of two 3/8-inch, Grade 8 fasteners, per 100 pounds. See General Regulations 4:2.

GROUND CLEARANCE

Minimum 3 inches from front of car to 12 inches behind centerline of front axle; 2 inches for the remainder of the car, except oil pan and headers.

PARACHUTE

Dual parachutes mandatory. Two separate shroud-line mounting points mandatory with sleeved 1/2-inch-minimum Grade 8 steel bolts with self-locking nuts or with nuts welded onto parachute brackets. Shroud-line mounting brackets must be constructed of minimum 3/16-inch 4130 steel. Fire-resistant protective covers must be on all parachute packs and unpacked shroud lines. Beginning January 1, 2022, pilot chutes must be made of a bright color, not black, to be visible on the racing surface if detached from the main chute. See General Regulations 4:8.

2026
Hot Rod Heritage Racing Series Rules Supplement

Two NHRA-accepted parachute tethers are required and must be routed through each shroud line end loop and be attached using the rear end mounting bolts on each side. The mounting attachments on each end of both tethers must attach to either separate rear end mounting bolts or opposite ends of a single bolt (one under the head of the bolt and the other under the nut). NHRA-accepted parachute tethers: Amick Race Car Restraints PARA-101REV1, Future Fibres FF30MLB-P-MB, or Taylor Motorsports 108. When Future Fibres FF30MLB-P-MB is used, only one tether is required and must be routed through each shroud line end loop and be attached using the rear end mounting bolt on each side. All tethers must be covered with a fire-resistant material.

ROLL CAGE

Chassis must have manufacturer's name, serial number, and date of manufacture. Chassis must meet SFI Spec 2.2 (front-engine cars). Effective Jan. 1, 2011, chassis must meet SFI Spec 2.2. Current certification will be accepted until they expire. Plating of chassis prohibited; painting permitted. Chassis must be inspected yearly by NHRA and have serialized sticker affixed to frame before participation. Roll-cage padding meeting SFI Spec 45.1 mandatory where driver's helmet may come in contact with roll-cage components. Additional padding, mounted on flat stock and fastened to the roll cage on both sides of the driver's helmet, mandatory. Additional padding must be NHRA-accepted, securely mounted using bolts or locking fasteners, and must include a flame-retardant covering. A current list of NHRA-accepted lateral head supports is available on NHRARacer.com. Pressurization of framerails in lieu of air bottles is prohibited.

SUSPENSION

Rigid rear suspension mandatory. Front suspension optional.

WHEELBASE

Minimum: 150 inches. Maximum: 225 inches on long side. Maximum wheelbase variation from left to right: 2 inches.

TIRES & WHEELS: 5

TIRES

Only M&H, part numbers MVD-004, MVD-005, MVD-010, and Hoosier, part number 18975, tires permitted. Race-only spec tires on front mandatory.

WHEELS

Minimum width: 10 inches. Maximum width: 12 inches, or as determined by spec tire requirements. Must be either beadlock design or use of a liner mandatory on non-beadlock wheels.

Beginning January 1, 2023, cars running 5.99 (*3.79) or quicker must use a SFI 15.3 drive wheel with either a liner or double bead lock. All wheels must bear a wheel conformance label indicating compliance with the SFI Certification it was originally built to. All 15.3 wheels must be recertified every 24 months.

INTERIOR: 6

SHEET METAL

2026
Hot Rod Heritage Racing Series Rules Supplement

All sheet metal within the driver compartment must be aluminum or steel. Magnesium prohibited.

UPHOLSTERY

Seats must be foamed with energy-absorbing material and formed to the driver's body. Minimum one-layer, flame-retardant material mandatory as seat upholstery.

BODY: 7

AIRFOILS

Side-mounted canard-type units permitted, securely mounted below the headers and in front of rear tires. Front wing permitted. Maximum canard wing surface 450 square inches per side. Canards may not extend more than 2 inches outside rear tire. Front wing must be no higher than top of front tires and may not extend outside of front tires. In addition, total front wing surface must not exceed 500 square inches. Maximum wicker on canards and front wings .500-inch. Canards and front wings only aerodynamic surfaces allowed. Any disguised surfaces prohibited. Maximum overhang limited to 30 inches, measured from the centerline of the forward-most front spindle.

BODY

Body and cowl must be metal, fiberglass, or carbon fiber/Kevlar. Driver compartment, frame structure, roll bars, and body must be designed to prevent driver's body or limbs from contacting track surface.

MOTORPLATE

Must be constructed of .250-inch aluminum or steel. Firewall must completely seal driver from engine. Magnesium prohibited.

ELECTRICAL: 8

IGNITION

Single Electronic Magneto System Permitted:

- One Point style magneto with one single coil
- One Electronic MSD 4.0 inch diameter body magneto generator □
- One MSD points box & MSD coil
- MSD Part Numbers: 8142 Red Coil, 8145 Red Point Box or MSD Part Numbers: 81423 Black Coil, 81453 Black Point Box

No amperage upgrades can be done to both the point and electronic style magnetos. Only commercially available 44 Amp magneto permitted, must not exceed manufacturers rated output. MSD 4 inch diameter body generators permitted. Rotation changes cap size and magneto drive adapter can be changed to adapt to different magneto drives and engine combinations.

Traction control devices and MSD Grids prohibited. Battery connection between magneto generator and MSD points box prohibited.

Timing retard must be a function of the driver by mechanical or pneumatic means only.

A functional positive action, ignition ON/OFF switch located in the driver's compartment capable of de-energizing the entire system is mandatory. Driver must be able to easily access and operate the ignition ON/OFF when seated in a normal driving position while seat belts are secured. Momentary contact with prohibited. The ignition ON/OFF switch is to be used to shut off the engine if the fuel shutoff does not function properly.

SUPPORT GROUP: 9

DATA RECORDERS

Data recorders allowed but only for the purpose of gathering data; they can perform no function of engine, clutch, ignition, or fuel-system control. See General Regulations 9:1, 9:2.

FIRE EXTINGUISHER SYSTEM

Fire extinguisher system meeting SFI Spec 17.1 mandatory. Minimum 20-pound or more NHRA-accepted fire extinguishing system mandatory. Activation cables must be protected in bellhousing and engine area. Activation cables and distribution tubing must be steel. Must be installed per manufacturer's specifications. Carbon-fiber bottles prohibited. See General Regulations 9:3.

AIR BOTTLES

No compressed air or similar devices allowed on car (except for use with a parachute only).

JACKS AND JACK STANDS

No work may be done under any car in the pits while supported by a jack. No car may be fired while on a jack. Jack stands are required while work is performed or while car is being warmed up. A licensed driver must be in the seat anytime the engine is running. Jack-stand devices must provide a minimum ground clearance of 7 inches from bottom of rear tire to ground while car is running.

PUSH STARTS

Prohibited.

SHUTOFF DEVICE

Properly installed and operational Electrimotion Nostalgia Shutoff Controller Kit (part number SB003) mandatory. The Electrimotion Nostalgia Shutoff Controller Kit must be installed per manufacturer's instructions. Beginning July 1, 2018 the Electrimotion Shutoff Receiver (part number RF001) is mandatory. Modification of or tampering with the Electrimotion Nostalgia Shutoff Controller Kit is prohibited. The Electrimotion Crew Alert Box, part number CB001, may be used in conjunction with the Shutoff Device to illuminate a dash light for driver notification, disengage throttle and /or enable the shutoff device. Any other use of the Crew Alert box is prohibited.

DRIVER: 10

ARM RESTRAINTS

Mandatory. See General Regulations 10:3.

CREDENTIALS

Valid Nostalgia Top Fuel or equivalent license mandatory. See General Regulations 10:4.

DRIVER RESTRAINT SYSTEM

2026
Hot Rod Heritage Racing Series Rules Supplement

Minimum 6-point, driver restraint system meeting SFI Spec 16.1 or 16.5 mandatory. All belts and mounting points must be covered with a fire-resistant material. Restraint system must be updated at two-year intervals from date of manufacture.

HELMET

Full-face helmet meeting Snell: SA2015, SA2020, SA2025, or FIA: 8860-2010, 8859-2015, 8860-2018, or 8859-2024 mandatory with shield. Beginning January 1, 2022, Eject Helmet Removal System (part number SDR 890-01-30) mandatory and must be installed per manufacturer instructions. A Stand 21 Lid Lifter head sock meeting SFI 3.3 may be used in lieu of the Eject Helmet Removal System. See General Regulations 10:7.

HEAD AND NECK RESTRAINT DEVICE/SYSTEM

At all times that the driver is in the race vehicle, from the ready line until the vehicle is on the return road, driver must properly utilize an SFI-approved head and neck restraint device/system, including connecting the helmet as required for full functionality of the device. The device/system must meet SFI Spec 38.1 and must display a valid SFI label. The head and neck restraint device/system, when connected, must conform to the manufacturer's mounting instructions, and it must be configured, maintained, and used in accordance with the manufacturer's instructions.

PROTECTIVE CLOTHING

Driver's one-piece suit meeting SFI Spec 3.2A/20, long sleeve underwear shirt meeting SFI 3.3, long underwear pants meeting SFI 3.3, SFI Spec 3.3/20 gloves, glove underliners made of flame retardant material, SFI Spec 3.3/20 boots, socks meeting SFI 3.3, SFI Spec 3.3 head sock, and SFI Spec 3.3/10 helmet skirt mandatory. All clothing containing metal or plastic prohibited. Undergarments that are worn in addition to those mandated that are made of flammable materials (e.g., nylon, rayon, polyester, spandex etc.) are prohibited. All jewelry prohibited. All jackets and pants or driver suit that meet the SFI Spec 3.2A/20 must be recertified on a five-year interval. See General Regulations 10:10.

SECTION 9: AUTHENTIC HISTORIC VEHICLE

The requirements for the inclusion of an authentic historic drag race vehicle or replica in this program are as follows:

The owner must submit to the NHRA Exhibition Committee an application that includes a full description of the vehicle to include, but not limited to:

- Chassis drawings
- Tubing sizes and tubing placement
- Photographs (front, rear, side, and three-quarter-side views)
- All safety equipment and shutoffs
- Fuel type Proposed speed and elapsed time limits
- Engine details
- Supercharger
- Rear end
- Brake system
- Parachute
- Tires and wheels

2026
Hot Rod Heritage Racing Series Rules Supplement

- Driver safety equipment

A special Selection Committee shall be established to consider applications for inclusion in this program. The Selection Committee shall comprise:

- Executive Director-The Wally Parks NHRA Motorsports Museum
- Curator-The Wally Parks NHRA Motorsports Museum
- National Technical Director
- Nostalgia Technical Advisors

This Committee shall be chaired by the Vice President-The Wally Parks NHRA Motorsports Museum.

Authentic historic vehicles and replicas should meet the following requirements to be considered for inclusion in this program:

All chassis and/or frames must be original or suitable replica. The amount of repair and/or restoration allowed shall be determined by the committee. Only one active replica of an original true historic vehicle may be included in this program.

Vehicles should represent recognized participants from a significant era of organized drag racing history.

Vehicles accepted for inclusion in this program will be assigned to one of the following categories:

Category I: Display and engine starts only. May not make runs of any kind. No licensing required for this category.

Category II: May perform burnouts only.

Category III: May make full-throttle runs to the eighth-mile only.

Licensing procedures required for Category III only.

The primary objective of this program is the preservation and active presentation of authentic historic vehicles and replicas that would by upgrade to current NHRA rules be altered to the point of loss of identity, recognition, and/or historic value.

Each vehicle to be considered for inclusion in this program must be inspected for adherence to its requirements by a person appointed by the Selection Committee, who shall report his or her findings. These findings will then be provided to the Selection Committee members for their consideration.

Authentic historic vehicles will be evaluated on an individual basis and will be assigned by the Selection Committee to one of the categories of participation listed previously.

Vehicles must then be certified by an SFI-certified chassis inspector who will be designated by the Selection Committee. Vehicle and driver will be licensed as a

2026
Hot Rod Heritage Racing Series Rules Supplement

combination. Chassis must be inspected, certified, and tagged every three years. The fee for this inspection and certification will be \$200.00.

Applicants should contact the NHRA Technical Department for license forms and further information.

SECTION 10: CACKLEFEST VEHICLE

The Cacklefest is an event created to celebrate the era known as The Golden Age of Drag Racing. Simply put, restored and/or accurately recreated race cars are push started by an era correct car or truck. After the engines are started, the race cars are lined up in a designated area in front of spectators and left running at an idle making the distinctive cackling sound of a nitro fueled engine. The NHRA Motorsports Museum created the event in 2000 with an exhibition of nine cars. Since then, the Museum is proud and grateful that dozens of functional Top Fuel dragsters now provide a nostalgic look back at early drag racing for older fans and an educational and exciting event for those too young to remember.

REQUIREMENTS & SPECIFICATIONS

GENERAL

All vehicles must be in good working order, with all components in proper mechanical condition including frame construction, brakes, steering, wheels, and tires, etc. All drivers - of both cacklefest car and push vehicle, must have demonstrated experience to participate in push start Cacklefest activity.

CACKLEFEST PRE-EVENT INSPECTION

Prior to any engine starts at Cacklefest events, including National and California Hot Rod Reunions®, and select NHRA National Events, all participating cars must have complied with a **tech inspection**. Inspections will be conducted by experienced personnel. Proper Waivers and Releases must be signed prior to any engine starts - both static and push start.

ENGINE: 1

IGNITION/MAGNETO

Must have functional, positive action, ON/OFF switch located in driver's compartment capable of de-energizing the entire ignition system. Driver must be able to easily access and operate ignition switch when seated in normal driving position, with all belts secured. "Momentary contact" switch prohibited. Magneto switch is to be used to shut off engine if fuel shutoff does not function properly.

THROTTLE/LINKAGE

Each vehicle must have a foot throttle incorporating a positive-acting return spring attached directly to the carburetor/injector throttle arm. A positive stop or override prevention must be used to keep linkage from passing over center and sticking in an open position. System must be free of binding.

FUEL SHUTOFF/CABLE

Each vehicle must be equipped with a fully functional, quick-action, fuel-shutoff valve. Valve must be positioned at the outlet/pressure side of fuel pump. Valve must be controlled with positive-action device/cable where driver has full ON/OFF control. Driver must be able to easily access and operate fuel shut off system when seated in normal driving position, with all belts secured.

DRIVETRAIN: 2

CLUTCH/LINKAGE

All vehicles must be equipped with automotive-type clutch using single or multiple disks. Fully centrifugal type clutches (Crower Glide, etc.) prohibited**. Use of supplemental counterweights prohibited. Spring pressure is not to exceed normal operation requirement to start engine. Clutch adjustment settings must provide for full disengagement at any and all rpm. Clutch linkage must be in proper working order and provide driver with full range of control. Driver must have adequate leverage/control of clutch pedal to easily and fully disengage clutch at any and all rpm. **Vehicles equipped with fully centrifugal clutches permitted to perform static starts only if driveline is fully disconnected.

DRIVELINE

Drivelines must be completely disengaged during any static starts when drive wheels are touching the ground either by disconnecting coupler or use of "in and out" device. Exception would be when undergoing a mandated tech inspection static start in a designated and secure area.

Vehicles not equipped with driveline disconnect devices must have drive wheels off the ground using fixed-position jack-stand devices for static starts in populated areas.

If necessary to make static start, with driveline engaged and tires on the ground, the car must be relocated to a designated remote area free of spectators.

SUPPORT GROUP: 9

FIRE EXTINGUISHER

All participants making static starts must have a functional fire extinguisher near the car at any time the engine is running. Extinguishers must be carried in all push-start cars or trucks.

PUSH VEHICLE

Each entrant must have a "period correct" push vehicle for the Cacklefest presentation.

All push vehicles must be in good mechanical condition and must display a current license and registration. Proof of insurance may be requested before the vehicle can operate. Push vehicle should be known to be free of leaks and have adequate cooling system to prevent coolant overflow or spills.

Watch signals from official controlling the flow of cars. If the driver of the cacklefest car is unable to start the car in the area designated by the official, DO NOT MAKE ANY

FURTHER ATTEMPTS TO START THE CAR. Drivers of cacklefest car and push vehicle must be able to communicate a failure to start and then proceed to carefully push the car to its designated parking location or return to the pits by the path indicated by the official.

DRIVER: 10

DRIVER RESTRAINT SYSTEM

Seat belts and shoulder harnesses must be in good condition and fully utilized during any push start procedure.

PROTECTIVE CLOTHING

During any push-start procedures, including “practice starts,” drivers are required to wear a jacket meeting SFI Spec 3.2A/1, full-length pants, closed-toe shoes, socks, gloves, helmet, mask, and goggles. Nylon or nylon-type clothing (i.e., gloves, pants, socks, or shoes) prohibited.

Note: During static starts, drivers are required to wear shirts (no tank tops), full-length pants, socks and closed-toe shoes.

CREDENTIALS

All drivers participating in push-start Cacklefest events must have demonstrated full capability to operate vehicle with multiple starts required to be included in feature events. Drivers may be asked to demonstrate the ability to locate, and operate, all controls even when blindfolded.

Drivers of all Cacklefest vehicles, and drivers of all push vehicles, must possess a valid state driver’s license.

SECTION 11: GENERAL REGULATIONS

Throughout this Supplement, a number of references are made for particular products to meet certain specifications (i.e., SFI Specs, Snell, DOT, etc.). It is important to realize that these products are manufactured to meet certain specifications, and upon completion, the manufacturer labels the product as meeting that spec. Therefore, except as outlined under SFI requirements, any change to the product voids that certification.

Under no circumstances may any certified product be modified, altered, or in any way vary from the “as manufactured” condition. Such a practice is in violation of the SFI, Snell, DOT, etc. program, voids such certification and therefore will not be accepted by NHRA.

Notice: It is the responsibility of the participant, not NHRA or any track, to ensure that all safety equipment is approved and is correctly installed, worn, maintained and used.

REQUIREMENTS & SPECIFICATIONS

ENGINE: 1

1:1 COOLING SYSTEM

All cooling systems/radiators must be installed in the stock location for body style used. Front-engine dragsters must have system installed in front of engine. See 4:3 DEFLECTOR PLATE.

1:2 ENGINE

All functions of engine, fuel, timing, clutch, and throttle must be a direct function of the driver.

Classes limited to automotive engines only unless otherwise stated under Class Requirements. Contestants in weight-to-cubic-inch classes must claim cubic-inch displacement of engine used; under no circumstances may claimed displacement exceed actual displacement by more than 5 cubic inches. No allowance for overbore; any part of a cubic inch is rounded off to the next highest inch (i.e., 301.2 = 302). If engine size is changed during a race, competitor must report to Technical Department supervisor before a run is attempted. Crankshaft centerline must not exceed 24 inches from ground in any class. Engine must be mounted to frame by a minimum of two 3/8-inch-diameter Grade 5 bolts. Valvetrain must incorporate conventional automotive coil spring design; pneumatic-type valvetrains are prohibited in all classes. All classes, with the exception of Stock and E.T. cars slower than 10.99 seconds, harmonic balancer meeting SFI Spec 18.1 or solid metallic hub mandatory. All cars with pressed-on front harmonic balancers must have such installed to protect accidental loss (i.e., drilled and bolted). Ceramic bearings prohibited in all NHRA categories.

1:3 EXHAUST

All vehicles must be equipped with exhaust collectors, headers, or stacks installed to direct exhaust out of vehicle body to rear of car, away from driver and fuel tank. No part of the exhaust system may be routed through the driver's compartment. Exhaust system components must be securely fastened (i.e., metal connector straps, bolted, welded, etc.) to prevent loss of system components during competition. All removable multi-piece exhaust collectors/stacks must be securely fastened with either an NHRA-accepted header tether, a minimum 1/2" (half-inch) stitch weld located on each primary tube or be permanently attached to the vehicle body or frame with positive fasteners (i.e., exhaust hangers, support brackets, bolts/nuts, etc.) such that they require tools for removal. A current list of NHRA-accepted header tethers is available on NHRARacer.com. Flexible tubing or "flex pipe" prohibited in all categories. If mufflers are used, they must be securely attached to exhaust system and vehicle body or frame.

Part of NHRA's mission is to preserve the right to race. In many communities, the right to race is contingent upon reducing noise and complying with local noise and muffler laws, ordinances, regulations, or agreements. Therefore, all competitors must comply with any muffler rules applicable to his or her class in the Rulebook and must comply with any noise-reduction requirements (including mufflers) mandated by any member track at which he or she races. Member tracks have the authority to impose muffler rules and noise regulations beyond those required by the NHRA Rulebook.

1:4 FLASH SHIELDS

Carburetor inlet must not be openly exposed. In lieu of hood, carburetors must be equipped with a flash shield or velocity stacks that cover the top, back, and sides, preventing fuel from being siphoned into the airstream or blown into driver's face. Additionally, any car that is driven, not towed, through the pits, with open stack(s) not protected by hood or scoop, must have screening installed on open stack(s) to prevent items from entering stack.

1:5 FUEL SYSTEMS

Location: All fuel tanks, lines, pumps, valves, etc. must be outside of the driver's compartment and within the confines of the frame and/or steel body. Cool cans, fuel-distribution blocks, etc. must be located at least 6 inches forward of the flywheel/bellhousing area on rear-wheel-drive (RWD) vehicles. Fuel pressure gauge isolators, with steel braided line, may be mounted on firewall.

Tanks: When permitted by class regulations, fuel tanks located outside body and/or frame must be enclosed in a steel tube frame constructed of minimum 1 1/4-inch O.D. x .058 chromoly, Docol R8, or .118 mild steel tubing. All fuel tanks must be isolated from the driver's compartment by a firewall, completely sealed to prevent any fuel from entering the driver's compartment. All fuel tanks must have a pressure cap and be vented outside of body. A positive-locking screw-on fuel tank cap is mandatory on all open-bodied cars. Insulated fuel tanks prohibited. When used, nonmetallic fuel cells must have a metal box protecting the part of the fuel cell that is outside of body lines or trunk floor, excluding hose connection area in rear. Non-metallic fuel cells or tanks must be grounded to frame.

Lines: All non-OEM fuel lines (including gauge and/or data recorder lines) must be metallic, steel braided, or NHRA-accepted "woven or woven-pushlock." A maximum of 12 inches total (front to rear) of non-metallic or non-steel braided hose is permitted for connection purposes only; individual injector nozzle and motorcycle fuel lines are excluded. Fuel lines (except steel braided lines) in the flywheel/bellhousing area must be enclosed in a 16-inch length of steel tubing, 1/8-inch-minimum wall thickness, securely mounted as a protection against fuel-line rupture. Fuel lines may not be routed in the driveshaft tunnel. It is mandatory that fuel lines passing supercharger drive belts be steel braided, NHRA-accepted woven or woven-pushlock, or be enclosed in protective steel tubing. A current list of NHRA-accepted woven or woven-pushlock fuel lines is available on NHRARacer.com. All NHRA-accepted fuel lines must use ends that are specifically designed for the type of fuel line being used. No hose clamps allowed on NHRA-accepted fuel lines.

Pumps/Valves: Cars with non-OEM-type mechanical fuel pumps must have a quick-action fuel-shutoff valve within easy reach of driver and located in the main fuel line between the fuel tank and the carburetor and/or injectors. Fuel recirculation systems not part of normal fuel/pump system prohibited.

Fuel/Air: Any method of artificially cooling or heating fuel prohibited (i.e., cool cans, Freon, wet rags, etc.), except as noted in Class Requirements. Wet towels, rags, ice, etc. must be removed before vehicle leaves staging area. Coolers, chillers, etc., where permitted by Class Requirements, are prohibited outside of the competitor's pit. Ambient temperature air only; cooling or otherwise changing the conditions of the intake air is prohibited. Spraying of intake with any artificial spray or coolant prohibited.

Alternative Fuels: Containers for alternative fuels must be permanently labeled by the manufacturer as suitable for CNG or propane. Tank must be vented outside of body. Alternative fuel systems must incorporate pressure-relief valve meeting standards listed in NFPA 52. Alternative fuel systems must incorporate a manual shutoff valve according to standards listed in NFPA 52 for CNG vehicular systems. All hoses/lines used for alternative fuels must be permanently and distinctively marked by the manufacturer as to manufacturer name or trademark, service identifier, and design pressure. Plastic, cast iron, galvanized, copper, or aluminum pipe or hoses prohibited.

1:6 FUEL

Racing Gasoline: A current list of NHRA-accepted racing gasoline is available on NHRARacer.com. For all categories using racing gasoline, racing gasoline is defined for purposes of this Rulebook as a mixture of hydrocarbons only. Non-cyclic olefinic hydrocarbons and non-hydrocarbons that do not increase the specific energy of the gasoline are allowed to the extent they do not exceed 1 percent (1%) by volume and are blended in the gasoline by the refiner or fuel manufacturer. Non-hydrocarbons that do not increase the specific energy of the gasoline are allowed to the extent that they do not exceed 0.15 percent by volume and are blended in the gasoline by the refiner or fuel manufacturer. Racing gasoline is a good electrical insulator, or dielectric, and its relative effectiveness as an insulator is represented by its Dielectric Constant. The average D.C. for the hydrocarbons that make up gasoline is 2.025. This is defined as a reading of "0" with the NHRA Fuel Check meter. Racing gasoline is tested and certified at NHRA events by the application of various chemical analyses as considered appropriate by Fuel Check personnel. Racing gasoline in a vehicle may be checked before use in competition.

Methanol: Methanol is a clear, colorless liquid with a mild odor at ambient temperatures. Methanol is sold in two U.S. Federal Grades: A and AA. Either grade is permitted for use in NHRA competition, and racers should ensure that the methanol they purchase meets federal standards of purity. The purity standards for each grade are shown in the table below.

SPECIFICATIONS FOR PURE METHANOL

| Property | Grade A | Grade AA |
|--------------------------------------|---|----------|
| Methanol content, wt percentage, min | 99.85 | 99.85 |
| Acetone and aldehydes, ppm, max | 30 | 30 |
| Acetone, ppm, max | 20 | |
| Ethanol, ppm, max | 10 | |
| Acid (as acetic acid), ppm, max | 30 | 30 |
| Water content, ppm, max | 1500 | 1000 |
| Specific gravity, 20C | .7928 | .7928 |
| Permanganate time, min | 30 | 30 |
| Odor | Characteristic | |
| Distillation range at 101 kPa | Not more than 1°C, including (760mm Hg) 64.6 +/- 0.1°C at 760mmHg | |
| Color, platinum-cobalt scale, mix | 5 | 5 |
| Appearance | clear-colorless | |

2026
Hot Rod Heritage Racing Series Rules Supplement

| | | |
|---|------|------|
| Residual on evaporation, g/100 mL | .001 | .001 |
| Carbonizable impurities; color platinum-cobalt scale, max | 30 | 30 |

Methanol is tested and certified at NHRA events by the application of various chemical analyses as considered appropriate by Fuel Check personnel. To be considered legal, methanol used in NHRA competition must meet the federal standards of purity. Any deviation from these standards because of impurities (beyond the limits established in the federal specification) in the fuel sample will result in disqualification. Because methanol is a hygroscopic substance, it readily absorbs moisture from the air, which rapidly renders methanol illegal as a fuel for use in NHRA competition. Racers are cautioned to keep methanol containers tightly capped at all times to minimize the absorption of water. Racers are encouraged to have Fuel Check personnel check samples of their methanol any time there may be doubt as to its purity.

Nitromethane: Only nitromethane from an NHRA-accepted supplier may be brought on site or used on site at any NHRA Series event. NHRA will designate accepted suppliers of nitromethane that may be brought on site and/or used on site at NHRA Events. To be eligible for competition, fuel teams must use nitromethane from one of the accepted suppliers. All nitromethane will continue to be required to contain a marker that changes color when the nitromethane has been sensitized or contaminated; no clear nitromethane will be allowed. Fuel, whether in the vehicle or otherwise, as well as transporters and pit areas, will be checked for compliance with this rule as deemed appropriate by NHRA. Any participant who violates any rule regarding nitromethane shall be banned from competition at the applicable event, or shall be subject to such other penalty deemed appropriate by NHRA.

Nitromethane Regulations

The Department of Homeland Security (DHS) continues to regulate the use and handling of nitromethane. NHRA has stressed for many years the importance of being not only responsible, but leaders, in the area of nitromethane security. The use of nitromethane in the sport of NHRA Drag Racing is vital to our sport and we need to take necessary measures to ensure its use for the foreseeable future.

The law requires anyone who possesses 400 pounds (44 gallons) or more of nitromethane to complete and submit a "Top Screen" questionnaire to the Department of Homeland Security. The Top Screen questionnaire is an exhaustive screening tool that requires a great deal of detail to complete. Failure to comply can lead to penalties up to \$25,000 per day or having the racing activity shut down. For additional information and instruction, we encourage you to contact the Department of Homeland Security.

NHRA cannot stress enough the importance of everyone in the racing community continuing to be conscious of the issues around nitromethane.

Nitrous Oxide: Prohibited.

Propylene Oxide: The use of propylene oxide is prohibited in all categories.

1:7 LIQUID OVERFLOW

All cars in competition with any type of water overflow capable of spilling water must have a catch can to accumulate the excess liquids and prevent leaking onto the track. Minimum catch can capacity: 1 pint. Catch can must be securely fastened; i.e., bolted, clamped. Overflow may be routed into headers on cars that are supercharged or burn nitromethane or alcohol.

1:8 LOWER ENGINE CONTAINMENT DEVICE

When required, an SFI Spec 7.1 or 7.2 Lower Engine Containment Device must cover the sides of the block and pan up to within one inch of the head mating surface and extend to within 1 1/2 inches of the front and rear of the cylinder case area. The front and rear oil pan must be covered upward to the pan rail. The device must be free of cuts, tears, openings, etc. that would allow oil to escape. The device must be secured with a minimum of four straps, one at each corner. A positive device must be used to cover and contain external oil pumps that fasten directly to the engine; this device must fit such that it will contain oil from an engine failure. The device must have a solid member (hard part) along the top edge to form a zero air gap between the sides of the device (and/or the absorbent material) and the engine block. SFI Spec 7.1 devices must be updated/recertified by the original manufacturer at one-year intervals.

1:9 OIL SYSTEM

Accu-sump, dry-sump tanks, oil filters, oil supply lines, etc. prohibited in driver compartment and outside of frame and/or steel body/fenders, except as noted in Nostalgia Top Fuel. Oil-pressure gauge and line permitted in driver compartment, metal or steel braided line mandatory, maximum 3/16-inch inside diameter. Power-enhancing additives prohibited.

1:10 SUPERCHARGER

Nostalgia Top Fuel, Nostalgia Funny Car, A/Fuel, and AA/GS: Refer to individual Class Requirements for supercharged specifications.

Roots-type: Maximum size: 14-71, 22 1/4-inch case length, 11 1/4-inch case width, 19-inch rotor length; maximum rotor diameter: 5.840 inches including fixed stripping. Rotors must be driven from the front; both external drive and internal gearing. The case must be one piece with removable front and rear bearing end plates; rotor must be contained within one-piece case. Rotor helix angle may not exceed that of a standard 71-series GM-type rotor (4 degrees per inch). Maximum overdrive see Class Requirements. Aluminum studs (supercharger to manifold) mandatory in Advanced E.T., A/Fuel, Nostalgia Funny Car, and Nostalgia Top Fuel. See Class Requirements for manifold burst panel and restraint specifications.

Roots-type high helix: Must adhere to same maximum case dimensions and maximum rotor cavity diameter as standard Roots. Rotor helix angle may not exceed 6.5 degrees per inch (123.5 degrees total over 19-inch maximum rotor length). Rotors must be driven from the front; both external drive and internal gearing. Use of high-helix supercharger prohibited. Maximum overdrive see Class Requirements. Aluminum studs (supercharger to manifold) mandatory. See Class Requirements for manifold burst panel and restraint specifications.

Manifold burst panel meeting SFI Spec 23.1 mandatory with alcohol or nitromethane. Any other use of double burst panels on any supercharger or manifold prohibited. Aluminum studs (supercharger to manifold) mandatory. Overdrive limits, as determined

2026
Hot Rod Heritage Racing Series Rules Supplement

appropriate by NHRA, are subject to adjustment at any time as dictated by performance. Variable multi-speed supercharger devices prohibited regardless of supercharger type.

ALL SUPERCHARGERS: For all cars running 9.99 seconds or quicker, fuel and/or oil lines must be shielded wherever they pass the supercharger drive belt. Either a belt guard or fuel/oil line guard may be used.

1:11 SUPERCHARGER RESTRAINT DEVICE

Supercharger restraint system meeting SFI Specs mandatory per Class Requirements. Nostalgia Top Fuel and Nostalgia Funny Car requires SFI 14.3. SFI Spec 14.1 restraint permitted with Roots-type 6:71 on alcohol. Restraint system must be updated at two-year intervals from date of manufacture. The blower restraint straps and fuel lines must be installed such that when the restraint straps are fully extended no load is placed on any of the fuel lines. See Class Requirements.

1:12 THROTTLE

Regardless of class, each car must have a foot throttle incorporating a positive-acting return spring attached directly to the carburetor/injector throttle arm. A positive stop or override prevention must be used to keep linkage from passing over center and sticking in an open position. In addition to return springs, some means of manually returning the throttle to a closed position by use of the foot must be installed on all altered linkage systems except hydraulically or cable-operated systems. Per Class Requirements throttle control must be manually operated by driver's foot; electronics, pneumatics, hydraulics, or any other device may in no way affect the initial throttle operation. Use of throttle stop type devices (mechanical only - no electronic, pneumatic or hydraulic adjustment during run allowed) may only be preset and non-adjustable from driving position. Cable throttle systems permitted. NHRA-accepted hand controls for the physically challenged permitted. Choke cables and brazed or welded fittings on steel cable prohibited. No part of throttle linkage may extend below frameroils.

1:13 VENT TUBES, BREATHERS

Mandatory as outlined in Class Requirements; permitted on all cars. Where used, the tubes must terminate into an acceptable, permanently attached catch tank with a minimum capacity of one gallon per engine (except as noted in Class Requirements). The catch tank must be baffled to keep overflow off track. Breather/vent tubes must be mechanically secured (tie-wraps prohibited) to the fittings and the fittings locked at both ends.

DRIVETRAIN: 2

2:1 ANTI-BLOWBACK DEVICE

If mandated by Class Requirements, a brace or device must be installed that will prevent the bellhousing or adapter shield from being blown rearward in the event of flywheel and/or clutch explosion. Material required is 4130 chromoly or Docol R8, minimum size is .875-inch O.D. x .083-inch wall tubing with 3/8-inch fasteners. Ball-lock pins prohibited.

2:2 AXLE-RETENTION DEVICES

All cars, except as noted in Class Requirements, must be equipped with a satisfactory means of rear-axle retention; minimum .120-inch aluminum or .090-inch steel bearing

retainer mandatory. Stock "C"-clip axle retention prohibited as outlined in Class Requirements.

2:3 CLUTCH

Each car in competition, except those with automatic transmissions, must be equipped with a foot-operated clutch incorporating a positive stop to prevent clutch from going over center or past neutral, as in the case of centrifugal units. All pedals must be covered with non-skid material. NHRA-accepted hand controls for the physically challenged permitted. All slider clutches must meet SFI Spec 1.2, 1.3, or 1.4 as outlined under Class Requirements. In Class Requirements that call for an SFI Spec 1.2 clutch, an SFI Spec 1.5 clutch can be used. Multidisc clutch assembly for non-OEM supercharged and nitrous-oxide injected, vehicles must meet SFI Spec 1.3, 1.4, or 1.5 and must utilize an SFI Spec 6.2 or 6.3 flywheel shield, except as noted in Class Requirements.

2:4 DRIVELINE

For cars with driveshafts that contain universal joints:

For all full-bodied and open-bodied cars running between 7.50 (*4.50) and 13.99 (*8.59) in place of a crossmember located behind but within 6 inches of the center of the front universal joint: A front driveshaft loop is required on all cars, except vehicles running 11.49 (*7.35) seconds or slower equipped with street tires. See Class Requirements.

Full-bodied cars 7.49 (*4.49) seconds and quicker with the OEM floor retained (i.e., OEM floor may be modified according to Class Requirements for transmission removal but must be intact from 6 inches behind the center of the front universal joint rearward): A front driveshaft loop is required. See Class Requirements.

Full-bodied cars 7.49 (*4.49) seconds and quicker with the OEM floor removed/replaced: Each end of the driveshaft must have a round 360-degree driveshaft loop within 6 inches of the U-joint, and a driveshaft tube is also required. See Class Requirements.

Open-bodied cars 7.49 (*4.49) seconds and quicker where the driveshaft passes any part of the driver's body: Each end of driveshaft must have a round 360-degree driveshaft loop within 6 inches of U-joint, and a driveshaft tube is also required. The driveshaft tube must extend the full length of the portion of the driveshaft that passes any portion of the driver's body or extend to within 6 inches of the centerline of the rear U-joint. For center-steer cars with the driver seated above the driveshaft in lieu of a driveshaft tube a plate above the driveshaft of minimum thickness .120-inch steel or titanium with a minimum of four attachment points to the chassis, using either minimum 5/16 SAE Grade 8 bolts, welded, or 1/4-inch push/pull pins may be used. The plate must be at least as wide as the seat. See Class Requirements.

For all cars with driveshafts that do not contain universal joints but pass any part of the driver's body: Each end of driveshaft must have a full 360-degree cover of minimum 1/16-inch steel or 1/8-inch aluminum. Rear cover must surround the coupler. Front cover must surround the driveshaft from the back of the reverser to the end of the splicer sleeve in the area of the driver's legs. All covers must be securely mounted to frame, suitable crossmember, reverser, or third member. See Class Requirements.

DRIVESHAFT LOOP DEFINITION: 360 degrees of enclosure, 1/4-inch minimum thickness and 2 inches wide, or 7/8-inch x .065-inch welded steel tubing, securely mounted to the frame or frame structure where available (or to the OEM floor or rocker box where a frame does not exist) and located within 6 inches of the front or rear universal joint for support of the driveshaft in event of U-joint failure.

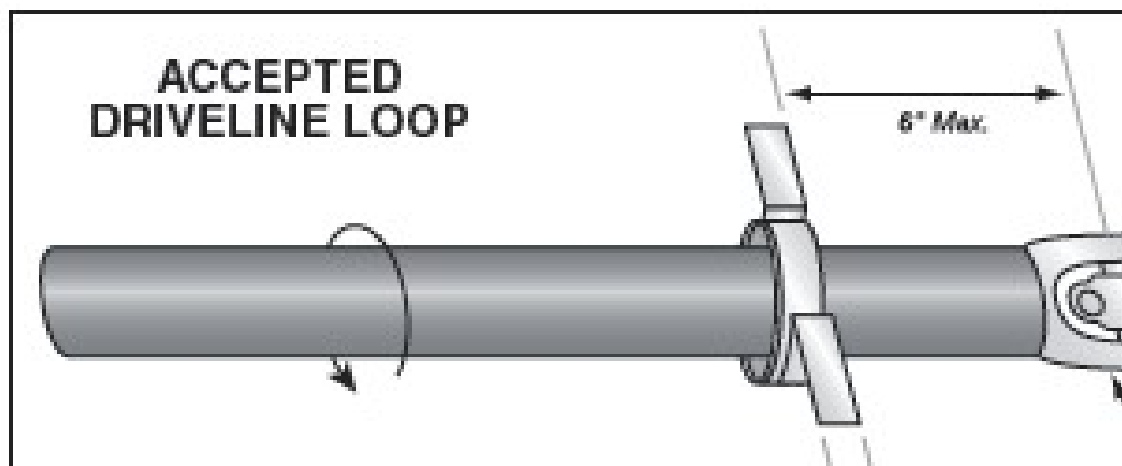

DRIVESHAFT TUBE DEFINITION: Driveshaft must be covered by a 360-degree round, oval, or tapered tube, covering the front U-joint and extending rearward a minimum 12 inches. Minimum thickness of tube is .050-inch steel or titanium. Driveshaft tube must utilize a minimum of four attachment points to the chassis, using either minimum 5/16 SAE Grade 8 bolts, welded, or 1/4-inch push/pull pins. Two-piece tube assembly permitted with a minimum of six 3/8-inch SAE Grade 8 bolts.

2:5 FLYWHEEL

The use of stock-type cast iron flywheels and/or pressure plates prohibited. The use of aluminum flywheels in Nostalgia Top Fuel and Nostalgia Funny Car is prohibited. Units meeting SFI Spec 1.1, 1.2, 1.3, 1.4, or 1.5 mandatory except as noted in Class Requirements.

2:6 FLYWHEEL SHIELD & MOTOR PLATE: General

The use of aluminum bellhousing is permitted in all categories and applications. The aluminum bellhousing must meet applicable SFI Specifications. Absolutely no modifications to as manufactured design are permitted on SFI Spec 6.1, 6.2 or 6.3 flywheel shields and/or liners. An SFI Spec 6.1W bellhousing is also acceptable wherever an SFI Spec 6.1 bellhousing is mandatory or permitted. All 6.2 and 6.3 titanium bellhousings must be reinspected and recertified yearly. SFI 6.1 titanium and aluminum bellhousings and SFI 6.2 or 6.3 steel bellhousings must be reinspected and recertified every two years (or as specified by the manufacturer). SFI 6.1 bellhousings must be reinspected and recertified every five years (6.1). Where SFI Spec bellhousings are mandatory, all applicable liners, large mounting fasteners, motor plates, etc., as required by SFI Specs or the manufacturer, must be properly installed. For all new flywheel shields and for all flywheel shields certified or recertified after Nov. 14, 2012, all liners must be flush with the motor plate; liners may be notched for starter gears/snouts.

2026
Hot Rod Heritage Racing Series Rules Supplement

Where an SFI 6.1 or 6.3 bellhousing is mandatory, a full, one-piece motor plate is also mandatory at the rear of the engine block. The motor plate must be constructed of 6061-T6, 7075-T6 or 2024-T3 wrought heat-treated aluminum alloy plate, minimum 1/8-inch thick for 6.1 applications, minimum 3/16-inch thick for 6.3 applications. In addition to the fastener requirements noted below, the SFI 6.3 flywheel shield must be fastened to the motor plate with four 1/2-inch-diameter Grade 5 shoulder bolts or high strength steel (or titanium) fasteners and nuts, one in each quadrant. Where an SFI 6.2 bellhousing is mandatory, see Section 2:8 for motor plate and fastener requirements.

The flywheel shield must be fastened to the engine and motor plate with a full complement (all available engine bolt holes or as specified by the manufacturer) of Grade 8 bolts or high strength studs. The use of Allen bolts to fasten the shield to engine or motor plate, to fasten covers, etc. is prohibited. All bolts (not studs or nuts) used for flywheel shield mounting, covers, etc. must be identifiable as to grade; all nuts and bolts associated with flywheel shield mounting, covers, etc. must be full standard depth, width, etc. (reduced thickness bolt heads, hollow bolts, half nuts, thin wall nuts, etc. prohibited). Maximum depth of flywheel shield is 8 5/8 inches, except Nostalgia Top Fuel, Nostalgia Funny Car, and Advanced E.T., maximum depth 9.4 inches (inside). Maximum thickness of all motor plates, mid-plates, and mounting plates installed between engine and flywheel shield is 1/2-inch, except SFI 6.1 which may be 1 1/4-inch maximum. All covers and fasteners associated with the flywheel shield must be installed prior to starting engine at any time, including warm-ups. Maximum spacing between flange fasteners in the flywheel shield is 7 inches. Chemical milling or any other structure-weakening procedure is prohibited. Welding to repair a flywheel shield is prohibited unless it is performed by the manufacturer and recertified by the manufacturer prior to use.

For cars equipped with an SFI 7.1 lower engine ballistic/restraint device, a maximum of two holes, each no larger than two inches in diameter (or 3.14 square inches equivalent area) are permitted. The holes must be located entirely below the horizontal centerline of the crankshaft. The holes must be at least 0.5-inch from any bellhousing bolt hole and be separated by at least two inches. SFI 6.2 flywheel shields may have one two-inch maximum diameter hole in the bottom of the back face of the shield. The opening in the motor plate for the crankshaft flange may not exceed the crankshaft flange diameter by more than one inch (except as noted for Top Fuel and Funny Car).

2:7 FLYWHEEL SHIELD: Nostalgia Top Fuel and Nostalgia Funny Car

Nostalgia Top Fuel and Nostalgia Funny Car equipped with a clutch must have a flywheel shield (bellhousing) that meets SFI Spec 6.2 and is labeled accordingly. All requirements for Nostalgia Top Fuel and Nostalgia Funny Car bellhousing installations are the same as for Top Fuel and Funny Car with the following exceptions:

A one-piece motor plate constructed of 1/4-inch minimum thickness 2024 T3, 6061 or 7075 T6 aluminum and fitting between the engine and flywheel shield according to the requirements of SFI Spec 2.2B, 2.1, or 10.1E is required. The motor plate must be attached to the chassis at the four corners with at least two welded mounting points utilizing minimum 3/8-inch-diameter Grade 8 bolts and full nuts. The remaining two

2026
Hot Rod Heritage Racing Series Rules Supplement

motor plate mounting points must be at least saddles fitting around the frameroils and secured with aircraft-type clamps or bolts (hose clamps prohibited).

The flywheel shield and motor plate are to be fastened to the engine by at least seven 3/8-inch diameter Grade 8 bolts or high strength steel or titanium studs threaded into the engine (3/4-inch minimum) and nuts of a similar material, above the centerline of the crankshaft. The motor plate must be fastened to the flywheel shield with at least eight 3/8-inch-diameter Grade 8 bolts or high strength steel alloy (or titanium) studs and nuts below the centerline of the crankshaft. The flywheel shield must also be fastened to the motor plate by four 3/4-inch-diameter Grade 5 shoulder bolts or high strength steel (or titanium) fasteners and nuts; one in each quadrant as required by SFI Spec 2.1 or 10.1E. Nostalgia Top Fuel and Nostalgia Funny Car: The opening in the motorplate for the crankshaft flywheel flange may not exceed the crankshaft diameter by more than one inch. See General Regulations 2:6.

2:8 FLYWHEEL SHIELD: A/Fuel

Cars equipped with a clutch must have a flywheel shield (bellhousing) that meets SFI Spec 6.2 and is labeled accordingly. All requirements for bellhousing installations are the same as for Nostalgia Top Fuel and Nostalgia Funny Car with the following exceptions:

A one-piece motor plate constructed of 1/4-inch minimum thickness 2024 T3, 6061 or 7075 T6 aluminum and fitting between the engine and flywheel shield according to the requirements of SFI Spec 2.2B or 10.1E is required. The motor plate must be attached to the chassis at the four corners with at least two welded mounting points utilizing minimum 3/8-inch-diameter Grade 8 bolts and full nuts. The remaining two motor plate mounting points must be at least saddles fitting around the frameroils and secured with aircraft-type clamps or bolts (hose clamps prohibited).

The flywheel shield and motor plate are to be fastened to the engine by at least seven 3/8-inch-diameter Grade 8 bolts or high strength steel or titanium studs threaded into the engine (3/4-inch minimum) and nuts of a similar material, above the centerline of the crankshaft. The motor plate must be fastened to the flywheel shield with at least eight 3/8-inch-diameter Grade 8 bolts or high strength steel alloy (or titanium) studs and nuts below the centerline of the crankshaft. The flywheel shield must also be fastened to the motor plate by four 3/4-inch-diameter Grade 5 shoulder bolts or high strength steel (or titanium) fasteners and nuts; one in each quadrant as required by SFI Spec 2.2B or 10.1E. The opening in the motorplate for the crankshaft flywheel flange may not exceed the crankshaft diameter by more than one inch. See General Regulations 2:6.

2:9 FLYWHEEL SHIELD: AA/Gas Supercharged and Junior Fuel

As described in Section 2:6, any modifications or alterations to the bellhousing by anyone other than the original manufacturer are prohibited. Bellhousing must be recertified by the original manufacturer following modification. Clutch adjustment slots, maintenance holes and covers, etc. must be installed by the original manufacturer.

See Section 2:6 for motor plate and general requirements. The flywheel shield must be fastened to the engine and motor plate with a full complement (all available engine bolt holes or as specified by the manufacturer) of minimum 3/8-inch-diameter Grade 8 bolts

or high strength steel studs above the centerline of the crankshaft. The motor plate must be fastened to the flywheel shield with at least eight 3/8-inch-diameter Grade 8 bolts or high strength steel alloy (or titanium) studs and nuts below the centerline of the crankshaft. An opening in the motor plate for an alternative starter location is permitted but it may not exceed 2 inches in diameter and when such an opening is present only one cooling hole is permitted in the motor plate.

All rear-engine cars must have a deflector plate to protect driver and fuel tank from engine. For Nostalgia Top Fuel and A/Fuel Dragster specifications, see Class Requirements. Plates must be made of minimum 1/8-inch aluminum or .060-inch steel or titanium. Must extend from top blower pulley to bottom pulley and be at least 1 inch wider than each pulley for supercharged cars. Other cars must have plate covering from shoulder height to bottom of chassis. On any enclosed engine/driver configuration, a full bulkhead must be installed, completely sealing the driver from the engine. Minimum attachment for any plate is four 5/16-inch, Grade 5 bolts. See 1:1 COOLING SYSTEM for additional requirements.

2:10 FLYWHEEL SHIELD: Other Classes

All other cars using a clutch and running 11.49 or quicker must be equipped with an SFI 6.1, 6.2, or 6.3 flywheel shield. See Section 2:6 for motor plate and general requirements. There shall be a minimum of seven 3/8-inch-diameter Grade 8 bolts or high strength steel studs in the top half of the bellhousing. There shall be a minimum of eight 3/8-inch-diameter Grade 8 bolts or high strength steel studs in the bottom half of the bellhousing used to fasten the bellhousing to the motor plate. Modifications or repairs to the flywheel shield prohibited except if performed and recertified by manufacturer.

All cars running 11.49 or quicker for which an SFI 6.1, 6.2 or 6.3 flywheel shield is not commercially available may use an SFI 6.1, 6.2 or 6.3 flywheel shield from another application and mount it to a motor plate that is mounted to the engine block at all available bolt holes; or must be equipped with a flywheel shield made of 1/4-inch minimum thickness steel plate, securely mounted to the frame or frame structure and completely surrounding the bellhousing 360 degrees. The flywheel shield shall not be bolted to either the bellhousing or engine. The flywheel shield must extend forward to a point at least 1 inch ahead of the flywheel and 1 inch to the rear of the rotating components of the clutch and pressure plate.

Titanium flywheel shields permitted.

2:11 REAR END

Welded spider gear rear ends prohibited in all classes. Four-wheel drive permitted per Class Requirements. Aftermarket axles and axle-retention device mandatory on any vehicle 10.99 or quicker; also mandatory on any car (regardless of class or E.T.) with a spool.

2:12 TRANSMISSION

All cars and trucks in competition except motorcycle- or snowmobile-powered dragsters must be equipped with a reverse gear.

2:13 TRANSMISSION, Aftermarket Planetary

Automated shifters are not allowed in any class.

2026
Hot Rod Heritage Racing Series Rules Supplement

A transmission shield covering transmission and reverser that meets SFI Spec 4.1 is mandatory if engine burns nitromethane; or engine burns methanol or nitrous oxide and runs 9.99 seconds or quicker; or vehicle runs 7.49 seconds or quicker; or engine is supercharged or turbocharged; or on any overdrive unit. Air shifter bottles must be stamped with DOT-1800 pound rating (minimum) and be securely mounted (i.e., no tie-wraps or hose clamps).

At least three bolts, 3/8-inch minimum, must be used to secure aftermarket planetary transmissions to bellhousing, except as noted in Class Requirements.

2:14 TRANSMISSION, Automatic/NHRA-Accepted

Automated shifters are not allowed in any class.

Any non-OEM automatic floor-mounted automatic transmission shifter must be equipped with a spring-loaded positive reverse lockout device to prevent the shifter from accidentally being put into reverse gear. Functional neutral safety switch mandatory. All transmission lines must be metallic or high-pressure-type hose. All vehicles running quicker than 10.99 seconds (*6.99) or faster than 135 mph and using an automatic transmission must be equipped with a transmission shield meeting SFI Spec 4.1 and labeled accordingly. ("Blanket"-type shield, appropriately labeled as meeting SFI Spec 4.1, permitted.) All non-blanket-type shields must incorporate two (or one, per manufacturer's instructions) 3/4 x 1/8-inch straps that bolt to the shield on each side and pass under the transmission pan, or transmission pan must be labeled as meeting SFI Spec 4.1. Permitted in all classes where an automatic transmission is used.

Any car 9.99 or quicker, and 135-mph or faster using an automatic transmission, Lenco Drive, or BRT must be equipped with a flexplate meeting SFI Spec 29.1 and covered by a flexplate shield meeting SFI Spec 30.1. Transmission that can utilize a high-gear transbrake must be supported by the use of two momentary buttons (one to arm the system, second as the main transbrake). Air shifter bottles must be stamped with DOT-1800 pound rating (minimum) and be securely mounted (i.e., no tie wraps or hose clamps).

All cars running 10.99 (*6.99) seconds and quicker must have an NHRA-accepted locking-type dipstick on the transmission and dipstick/filler tubes must be securely fastened (i.e., bolted, aircraft clamped). Wire ties, hose clamps, etc. prohibited.

BRAKES AND SUSPENSION: 3

3:1 BRAKES

Brakes on each car, regardless of class, must be in good working order with two-wheel hydraulic brakes on rear wheels as a minimum requirement. Four-wheel hydraulic brakes are recommended, or as specified under Class Requirements. Lightening of backing plates, brake drums, and/or brake shoes by cutting or trimming metal prohibited. Cooling or lightening holes may not be drilled in cast iron disc brake rotors. Aluminum rotors prohibited. If hand brake is used, brake handle must be inside car body or driver compartment. Brake lines must be steel, steel braided, or DOT-approved

2026
Hot Rod Heritage Racing Series Rules Supplement

flexible and routed outside the framerail, or enclosed in a 16-inch length of 1/8-inch minimum wall thickness steel tubing securely mounted where line(s) pass the flywheel bellhousing area and not routed in the driveline tunnel. All brake lines must be attached to chassis as per OEM style; hoses must have mounting brackets; no tie wraps, tape, etc. All brake lines on any rear-engine car must be protected inside of tubing or be braided steel construction where they pass the engine. All pedals must be covered with non-skid material. Secondary braking systems are permitted. NHRA-accepted hand controls for the physically challenged permitted. Automated braking systems prohibited; application and release of brakes must be a direct function of the driver; electronics, pneumatics, or any other device may in no way affect or assist brake operation. NHRA-accepted mechanical ABS systems permitted in all classes; contact NHRA Technical Department headquarters. If brake system includes a differential pressure switch, line-loc installed on front brakes must have solenoid installed after the differential switch. All line-locs (electric or hydraulic) must be self-returning to normal brake operating mode.

3:2 SHOCK ABSORBERS

Each car in competition must be equipped with one operative shock absorber for each sprung wheel. Shock absorbers may be either hydraulic or friction type, securely mounted, and in good working order. See Class Requirements.

3:3 STEERING

Each car's steering system must be secure and free of defects. All butt-welded parts must have additional visible reinforcement. Only conventional automotive steering systems are permitted; flexible steering shafts prohibited. Rear-wheel steering prohibited, unless vehicle was originally manufactured with an OEM system. An OEM system may not be modified, altered, or used in any manner inconsistent with manufacturer's specifications. All rod ends must be a minimum of 3/8-inch shank diameter and must be installed with flat washers of sufficient outside diameter to prevent bearing pullout. All steering boxes, sectors, and shafts must be mounted to the frame or suitable crossmember and cannot be mounted in any case to the bellhousing and/or bellhousing adapter shield, or motor plate. A secondary steering shaft stop must be installed to prevent long steering shaft from injuring driver in case of frontal impact (i.e., collar or U-joint pinned at crossmember, bracket, etc.). Commercially available quick-disconnect steering wheels permitted (except as noted in Class Requirements). Adapter must be welded to shaft. All fasteners must be of a positive nature; no roll or pressed pins, no ball-lock pins, set screws, etc. NHRA-accepted swing-away steering column permitted with removable steering wheel.

3:4 SUSPENSION

All cars must have a full suspension system of the type produced by an automobile manufacturer (i.e., springs, torsion bars, etc.). Rigid-mount front and/or rear axles are permitted when so indicated in Class Requirements. All rod ends must be installed with flat washers of sufficient outside diameter to prevent bearing pullout. Hollow rod ends are prohibited. **With the exception of unaltered OEM production Can-Am Spyder three-wheel motorcycles, three-wheel vehicles are not eligible for competition in any class.** Radius rods are not required on front axles that are rigidly mounted 18 inches or less from kingpin axis. Any front suspension using a beam or tubular axle must have radius rods attached to frame.

3:5 TRACTION BAR ROD ENDS

2026
Hot Rod Heritage Racing Series Rules Supplement

Minimum requirement for rod ends on the front of all ladder-type traction bars is 3/4-inch steel. A rod end strap to keep ladder bar secured in event of rod end failure mandatory in all classes. All traction devices that are not attached at front (i.e., slapper bars, etc.) must have a U-bolt or strap to prevent them from coming in contact with track.

3:6 WHEELIE BARS

Some classes limit length of wheelie bar — see Class Requirements. All wheelie bars, regardless of class, must have non-metallic wheels (i.e., rubber, plastic). Wheelie-bar wheels must turn freely at starting line, any preload prohibited. Wheelie bars must be fixed. Hydraulics, pneumatics, electronics, etc. or any adjustment or movement during run prohibited. Using wheelie-bar wheels as “fifth wheel” sensing device prohibited. Pressure sensors and parachute nets permitted. No other devices of any kind may be attached to the wheelie bar (e.g. cameras, other sensors etc.).

FRAME: 4

4:1 ALIGNMENT

Each car in competition, regardless of class, must have sufficient positive front-end alignment to ensure proper handling of car at all speeds.

4:2 BALLAST

As permitted in Class Requirements. Any material used for the purpose of adding to a car’s total weight must be permanently attached to the car’s structure and must not extend in front of or behind the rear of the car’s body or above the rear tires. No liquid or loose ballast permitted (i.e., water, sandbags, rocks, shot bags, metal weights, etc.). Discovery of loose or disguised ballast will result in disqualification from the event, regardless of whether infraction occurs during qualifying or eliminations. Additional penalties may be imposed in the sole and absolute discretion of NHRA. Weight boxes (two maximum) made of 1/8-inch material may be constructed to hold small items such as shot bags, lead bars, etc., as long as box and contents do not weigh more than 100 pounds or as outlined in Class Requirements. The box must be securely fastened to the frame or crossmember with at least two 1/2-inch-diameter steel bolts. Any liquid other than engine fuel being used, located behind the front firewall (on a front-engine car), is considered ballast and is prohibited, except for intercooler tanks that contain water and/or ice only. Tank must be securely mounted to frame, frame member, or OEM floorpan. To permit “making a class” due to a difference in scale calibration, a maximum removable weight of 100 pounds (or as outlined in Class Requirements) is permitted. Removable weight must be securely mounted to the frame or frame structure by a minimum of two 1/2-inch-diameter steel bolts per 100 pounds, or one 3/8- inch steel bolt per 5 pounds; all other weight bars, pucks, etc. must use minimum 1/2-inch-diameter SAE grade 8 bolts for attachment. Hose clamps, wire, strapping, tape, tie wraps, etc. for securing weight or ballast prohibited. Acceptable forms of ballast are 1) Heavier gauge steel floors (i.e., 16- or 18-gauge, heavier gauge and/or plate steel prohibited); 2) Frame reinforcing cross members; or 3) the addition of protective equipment such as roll bars, flywheel shield, etc. If additional ballast is needed and is permitted by Class Requirements, it must be permanently attached to frame, bolted with two 1/2-inch-diameter bolts per 100 pounds, with nuts welded to bolts. Maximum amount of removable and/or permanent ballast, unless otherwise stated under Class Requirements, is 500 pounds.

4:3 DEFLECTOR PLATE

See 1:1 COOLING SYSTEM for additional requirements.

4:4 FRAMES

Nostalgia Top Fuel, Nostalgia Funny Car, and any car 9.99 or quicker (see Class Requirements) must have a serialized chassis sticker affixed to frame before participating in any NHRA event. Certifications are available at NHRA events, or by making prior arrangements through a division office. Grinding of welds prohibited. All butt welds must have visible reinforcement (i.e., sleeve and rosette welds). Pressurization of framerails, roll bar, or roll cage in lieu of air bottles is prohibited. Visible reinforcement around any hole in any SFI Spec chassis (not just the roll cage) mandatory. Reinforcement must be of at least the same cross sectional area as the hole, at least .049-inch-thick chromoly or Docol R8 and completely welded around the outside. See also 4:10 ROLL BAR and 4:11 ROLL CAGE.

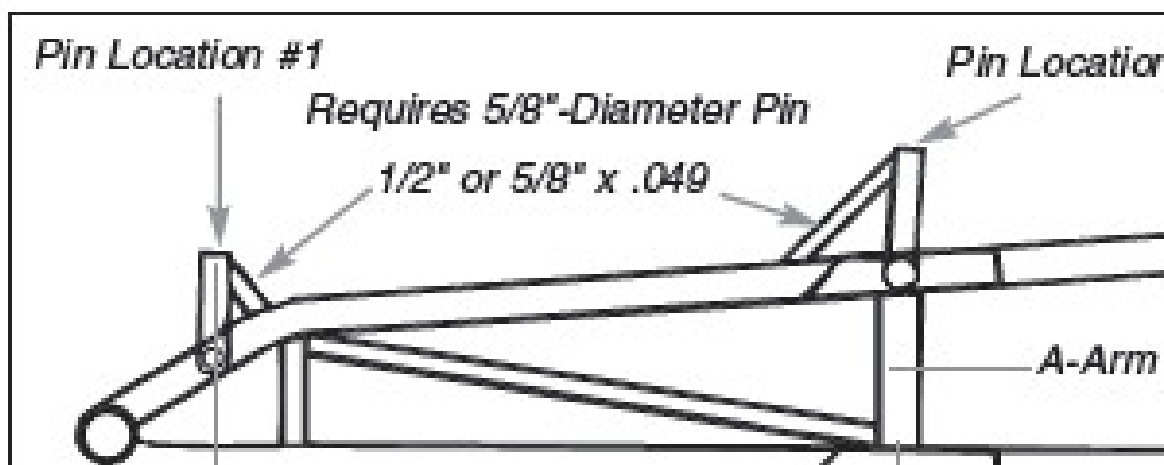

4:5 GROUND CLEARANCE

Minimum 3 inches from front of car to 12 inches behind centerline of front axle; 2 inches for remainder of car, except oil pan and exhaust headers where permitted. When permitted under Class Requirements, devices used for anti-rotation purposes (i.e., wheelie bars) are exempt from the 2-inch clearance rule.

4:6 MAGNAFLUX CERTIFICATES

Magnaflux certificates may be required by the technical inspector on any altered or welded parts.

4:7 MOUNTING HARDWARE

Hose clamps and tie wraps may be used only to support hoses and wires; all other components must be welded, bolted, aircraft clamped, etc. All self-locking fastener buttons must be metallic. All self-locking fastener buttons may be painted any color on their face, but must be WHITE or SILVER ONLY under the face. This rule applies to ALL cars in ALL classes.

4:8 PARACHUTE

If outlined in Class Requirements, it is mandatory to have a braking parachute produced by a recognized drag racing parachute manufacturer. Dual parachutes required for all cars running 200 mph or more or if required by Class Requirements. Tech inspectors may observe the proper operation of the parachute(s) and inspect for worn or frayed

2026
Hot Rod Heritage Racing Series Rules Supplement

shroud lines, ripped or dirty canopies, and worn or ragged pilot chutes. Parachute cable housings should be mounted solidly to frame tube or other suitable member no farther back than 1 inch from the release handle. If automated push-button release system is used, driver must also be able to use handle to manually release the parachute(s). The release housing must be attached within 12 inches of the parachute pack and in a manner that will allow the inner cable to release the parachute. When supercharged or using nitromethane as a fuel, it is mandatory that the parachute pack and unpacked shroud lines be protected with fire-resistant material from the mounting point to the pack. Parachutes must have their own independent mounting with sleeved 3/8-inch-minimum steel bolts or steel pins required for all applications unless otherwise stated in Class Requirements. The use of ball-lock pins for parachute mounting prohibited. Applications using two parachutes are required to have separate mounting points for each parachute system. Shroud-line(s) mounting brackets must be constructed of minimum .090-inch steel unless otherwise stated in Class Requirements. Safety pins must be red flagged and removed prior to burnout.

4:9 PINION SUPPORT

All cars using an open driveline must have radius arms, traction bars, or some suitable pinion support to prevent rear-end housing rotation.

4:10 ROLL BAR

All roll bars must be within 6 inches of the rear, or side, of the driver's head, extend in height at least 3 inches above the driver's helmet with driver in normal driving position, and be at least as wide as the driver's shoulders or within 1 inch of the driver's door. Roll bar must be adequately supported or cross-braced to prevent forward or lateral collapse. Rear braces must be of the same diameter and wall thickness as the roll bar and intersect with the roll bar at a point not more than 5 inches from the top of the roll bar. Crossbar and rear braces must be welded to main hoop. Sidebar must be included on driver's side and must pass the driver at a point midway between the shoulder and elbow. Swing-out sidebar permitted. All roll bars must have in their construction a cross bar for seat bracing and as the shoulder harness attachment point; cross bar must be installed no more than 4 inches below, and not above, the driver's shoulders or to side bar. All vehicles with OEM frame must have roll bar welded or bolted to frame; installation of frame connectors on unibody cars does not constitute a frame; therefore it is not necessary to have the roll bar attached to the frame. Unibody cars with stock floor and firewall (wheeltubs permitted) may attach roll bar with 6-inch x 6-inch x .125-inch steel plates on top and bottom of floor bolted together with at least four 3/8-inch bolts and nuts, or weld main hoop to rocker sill area with .125-inch reinforcing plates, with plates welded completely. Also the roll bar may be welded to frame connectors that are fully welded in place and are 1 5/8 inches x .118-inch MS or .083-inch CM round and/or 2 inches x 2 inches x .058 MS or CM rectangular. All 4130 chromoly tube welding must be done by approved TIG heliarc process; mild steel welding must be done by approved MIG wire feed or approved TIG heliarc process. Welding must be free of slag and porosity. Any grinding of welds prohibited.

Roll bar must be padded anywhere driver's helmet may contact it while in driving position. Adequate padding must have minimum 1/4-inch compression or meet SFI Spec 45.1. All cars running 9.99 (*6.39) or quicker, SFI Spec 45.1 mandatory.

4:11 ROLL CAGE

2026
Hot Rod Heritage Racing Series Rules Supplement

All cage structures must be designed in an attempt to protect the driver from any angle, 360 degrees. All 4130 chromoly tube welding must be done by approved TIG heliarc process; mild steel tube welding must be approved MIG wire feed or TIG heliarc process. Welding must be free of slag and porosity. Any grinding of welds prohibited. Plating of chassis prohibited for all cars manufactured after Jan. 1, 2003, unless otherwise noted in Class Requirements; painting permitted. Additionally, roll cage must be padded anywhere the driver's helmet may contact it while in the driving position. Beginning June 1, 2011, all cars running 9.99 (*6.39) and quicker, padding must meet SFI Spec 45.1. Additional padding mounted on flat stock and fastened to the roll cage on both sides of the driver's helmet mandatory in 7.0 Pro, Jr. Fuel, AA/Gas, A/Fuel, Nostalgia Funny Car, and Nostalgia Top Fuel. Additional padding must be NHRA-accepted (with manufacturer's name displayed), securely mounted using bolts or locking fasteners, and must include flame-retardant covering. A current list of NHRA-accepted lateral head supports is available on NHRARacer.com.

Open-Bodied Cars

When driver is in driving position in an open-bodied car, roll cage must be at least 3 inches in front of helmet. Cars without crossmember above driver's legs must have a strap or device to prevent legs from protruding outside chassis. On front-engine dragster, seat uprights and back braces must be arranged such that a flat surface passed over any two adjacent members will not contact the driver's seat or containment. Additional uprights, max 30 degrees from vertical, must be added until this requirement is satisfied. When non-vertical upright or "running W" side bay designs are used (i.e., uprights installed at greater than 30 degrees from vertical), adjacent roll-cage diagonals must be the same size as that required for the upright. Motor mount and/or rear-end uprights (except rear-engine dragster) may be rectangular tubing, 1 3/4-inch x 1-inch x .058 CM or MS minimum.

For all vehicles required to meet SFI Specification 2.1, 2.2, 2.3, 2.4, 2.5, 2.6, 2.7, 10.1 and 10.4 the upper roll-cage members must have head/helmet guards of one-inch by .058-inch round tube on all new chassis or at scheduled recertification.

Full-Bodied Cars

On full-bodied cars with driver in driving position, helmet must be in front of main hoop. If helmet is behind or under main hoop, additional tubing same size and thickness as roll cage must be added to protect driver. Main hoop may be laid back or forward, but driver must be encapsulated within the required roll-cage components. On unibody cars with stock floor and firewall (wheel tubs permitted), the roll cage may be bolted or welded to the floor/rocker box via 6-inch x 6-inch x .125-inch steel plates similar to the roll-bar attachment requirements of paragraph 4:10 in this section. Unless attaching to OEM floor or frame, the minimum requirements for a frame member or fully welded in place frame connectors on unibody cars to which a roll-cage member is attached are 1 5/8-inch x .118-inch MS or .083-inch CM round and/or 2-inch x 2-inch x .058 MS or CM rectangular.

All cage structures must have in their construction a cross bar for seat bracing and as the shoulder harness attachment point; cross bar must be installed no more than 4 inches below, and not above, the driver's shoulders, or to side bar. All required rear braces must be installed at a minimum angle of 30 degrees from vertical and must be

Hot Rod Heritage Racing Series Rules Supplement

welded in. Side bar must pass the driver at a point midway between the shoulder and elbow.

Unless an OEM framerail is located below and outside of driver's legs (i.e., '55 Chevy, '65 Corvette, etc.) a rocker or sill bar, minimum 1 5/8-inch x .083 CM or .118 MS or 2-inch x 2-inch x .058-inch CM or MS rectangular, is mandatory in any car with a modified floor or rocker box within the roll-cage uprights (excluding 6 square feet of transmission maintenance opening). Rocker bar must be installed below and outside of driver's legs and must tie into the main hoop, the forward hoop, frame, frame extension, or side diagonal. Rocker bar may not tie into swing-out side bar support. If rocker bar ties into side diagonal more than 5 inches (edge to edge) from forward roll cage support or main hoop, a 1 5/8-inch x .083 CM or .118 MS brace/gusset is mandatory between the diagonal and forward roll-cage support or main hoop.

Swing-out side bar permitted on OEM full-bodied car 8.50 e.t. and slower. The following requirements (a through d) apply:

- a. 1 5/8-inch O.D. x .083-inch CM or .118-inch MS minimum. Bolts/pins must be 3/8-inch-diameter steel, minimum and in double shear at both ends.
- b. Male or female clevis(es) permitted. Male clevis must use two minimum 1/8-inch-thick brackets (CM or MS) welded to each roll-cage upright; female must use minimum 1/4-inch-thick bracket (CM or MS) welded to each roll-cage upright. Pins must be within 8 inches of the vertical portion of both the forward and main hoops. A half-cup backing device must be welded to the vertical portion of the main hoop (inward side) or the upper end of the swing-out bar (outward side), minimum .118-inch wall (CM or MS) extending at least 1 5/8 inches past the center of the pins. A clevis assembly using a minimum .350-inch-thick male component and two minimum .175-inch-thick female components may use a 1/2-inch-diameter Grade 5 bolt and does not require a half-cup backing device.
- c. Sliding sleeves of 1 3/8-inch x .083 CM or .118 MS, with minimum 2-inch engagement, are permitted in lieu of the upper pin/cup.
- d. All bolt/pin holes in the swing-out bar must have at least one-hole diameter of material around the outside of the hole.

On all cars requiring a roll cage, if the OEM firewall has been modified (in excess of 1 square foot for transmission removal, not including bolted in components) a lower windshield or dash bar of 1 1/4 x .058-inch 4130 chromoly, Docol R8, or 1 1/4 x .118-inch mild steel is mandatory connecting the forward cage supports.

4:12 WHEELBASE

Minimum 85 inches, unless car has original engine in original location and is shorter than original or noted in Class Requirements. Maximum wheelbase variation from left to right is 1 inch, unless otherwise noted in Class Requirements.

TIRES & WHEELS: 5

5:1 TIRES

Tires will be visually checked for condition, pressure, etc. and must be considered free of defects by the technical inspector prior to any run. All street tires must have a

minimum of 1/16-inch tread depth. Temporary spares, space saver spares, farm implement or trailer tires prohibited. Metal, screw-in valve stems mandatory in tubeless tires, front and rear, on vehicles running 11.99 or quicker; unless OEM tire pressure monitor sensor is used. Chemically treating and physically altering (e.g., lightening, etc.) a tire in any manner is prohibited unless such treatment or alteration is performed by the original manufacturer.

5:2 WHEELS

Hubcaps must be removed for inspectors, who will check for loose lugs, cracked wheels, worn or oversize lug holes, and condition of spindles, axle nuts, cotter pins, etc. Snap-on hubcaps are prohibited on any class car. The use of "spinner" style wheels or any wheel design that incorporates movable pieces while vehicle is in motion or stationary are prohibited. Each car in competition must be equipped with automotive-type wheels with a minimum 12 inches of diameter unless Class Requirements stipulate otherwise. Motorcycle wheels or lightweight automotive wire wheels must be equipped with .100-inch minimum diameter steel spokes, properly cross-laced to provide maximum strength. All spoke holes in rim and hub must be laced. Omissions to lighten wheels prohibited. The thread engagement on all wheel studs to the lug nut, or lug bolts to wheel hubs, must be equivalent to or greater than the diameter of the stud/bolt. Length of the stud/bolt does not determine permissibility. (Example: A 7/16-inch stud must be thoroughly engaged through the threads in the hex portion of the lug a minimum of 7/16-inch.)

Wheel spacer permitted. Spacer to be either hub-centric or lug-centric and must fit with minimal clearance to retain concentricity. The wheel spacer must not reduce the minimum permitted thread engagement below the limits established by fastener diameter. (See example as stated above.) No stacking of wheel spacers allowed. Maximum rim width on any car: 17 inches. No rear wheel discs or covers permitted in any category.

INTERIOR: 6

6:1 DRIVER COMPARTMENT

Both doors must be functional from inside and outside on all full-bodied cars. All interior panels (firewalls, floors, wheel tubs, doors, etc.) within the driver compartment of enclosed-cockpit cars where the driver is located behind the engine must be constructed of materials other than magnesium. Driver compartment of any enclosed or full-bodied car must be totally sealed from engine and transmission. Openings around all linkages, lines, wires, hoses, etc. must be minimized.

6:2 UPHOLSTERY, SEATS

The driver's seat of any car in competition must be constructed, braced, mounted, and upholstered to provide full back and shoulder support. The driver's seat must be supported on the bottom and back by the frame or crossmember. Except as noted in SFI Specifications, seats must be bolted with four bolts (and nuts and washers) on the bottom and one bolt in the rear into crossbar; all bolts must go into frame or crossbraces. Ball-lock pins for seat attachment prohibited in all classes. All seats must be upholstered, or as noted under Class or SFI Requirements. Properly braced, framed, supported, and constructed seats of aluminum, fiberglass, carbon fiber, or double-layer

2026
Hot Rod Heritage Racing Series Rules Supplement

poly (accessory seats) permitted. Single-layer fiberglass seats must have steel tube framework, 1/2-inch-minimum O.D., for support. Aftermarket aluminum seats must have reinforced head rest. Magnesium seats prohibited.

6:3 WINDOW NET

An SFI 27.1 ribbon-type or mesh-type window net is mandatory on any full-bodied car running 7.49 (*4.49) or quicker. For full-bodied cars running 7.50 (*4.50) to 9.99 (*6.39) or if vehicle runs 135 mph or faster, a ribbon-type or SFI 27.1 mesh-type window net is mandatory unless otherwise specified by Class Requirements. SFI 27.1 window net, when required, must be updated at two-year intervals from the date of manufacture. Window net must be securely mounted on the inside of the roll cage, with the permanent attachment at the bottom. All attachment points must be designed in an attempt to protect the driver and avoid contact with track surface or guard wall. Eyelet clips, dogleash hardware, hose clamps, etc. prohibited. Penetration of webbing, except as performed per manufacturer's instructions, prohibited. Any other modification to net must be performed by manufacturer.

BODY: 7

7:1 AIR FOILS, WINGS

Air foils, canards, wings, and spoilers other than original factory equipment are permitted only in open-bodied class cars or as noted in Class Requirements. A positive locking device to prevent movement mandatory. No part to be within 6 inches of rear tires. Spring-loaded spoilers, wings, or canards prohibited. Adjustment of air foils, wings, or spoilers during run prohibited. NOTE: A spoiler is mounted directly to the deck lid of the vehicle such that air passes only on the top side of the device. An air foil or wing is mounted on stands, struts, or pedestals such that air passes over the top and underneath the device. Minimum fastener size on all front wings, canards, etc. is 1/4-inch. Ball-lock pins prohibited.

Beginning Jan. 1, 2016: For all open-wheel/body cars where rear wings are permitted and mounted to the roll cage the wing may either be fully mounted to the roll cage via plates and/or short brackets; maximum 6 inches center-to-center between the upper (wing tab) and lower (roll cage tab) bolts or have a roll-cage shroud. A multi-piece shroud is permitted. The shroud must be constructed of minimum .075-inch Grade 2 ASTM-B-265 titanium or .090-inch 4130 steel and must be shaped to conform to the roll cage. The shroud must be attached to each of the side bars with a minimum of three 1/4-inch-minimum-diameter Grade 8 bolts and bosses per side, to the top with one 1/4-inch-minimum-diameter Grade 8 bolt and boss, and to the rear bars with a minimum of two 1/4-inch-minimum-diameter Grade 8 bolts and bosses per side. Tabs with bolt and nut, where the nut is welded to the tab, may be used in place of the bosses. Absolutely no components may be mounted to the helmet shroud above the top of the shoulder hoop. Bolt heads must be 1/2-inch hex-style head.

NHRA-accepted helmet shrouds must be made as a one-piece shroud, a two-piece shroud, where each half must overlap; or a three-piece shroud, that includes two side shields and the center section.

2026
Hot Rod Heritage Racing Series Rules Supplement

All shrouds must fully encapsulate the rear braces and the secondary roll-cage hoop on the sides and top; when viewed from the rear, the shroud must cover the complete visible roll-cage structure. On the bottom, the shroud must have 2-inch clearance between the upper frame rail/shoulder hoop; on the top and sides, the entire shroud must extend fully forward to at least the centerline of the side bars.

When the shroud is fabricated as a two-piece unit, the components must overlap a minimum of 3/4-inch per side.

On a three-piece shroud, the center/rear section of the shroud may stand off from/behind the side pieces by no more than $\frac{3}{4}$ inches at any point and must overlap each side a minimum of 1 $\frac{1}{2}$ inches. The side shrouds must extend to the centerline of the rear hoops.

7:2 COMPETITION NUMBERS

All contestants are required to display a permanent driver number at all NHRA events. Numbers on side windows must be a minimum 4 inches high and 1 $\frac{1}{2}$ inches wide. Class designation letters must be a minimum 3 inches high and 1 inch wide. Driver's competition number and class designation must be displayed in a legible manner in a contrasting color to the vehicle's background color, or light color on windows, in a prominent position, and be clearly visible to the tower personnel. Class and numbers must be in the form of permanent decals or paint. The use of shoe polish in any form is prohibited.

7:3 FENDERS

All vehicles in all classes must have re-rolled or beaded edges on altered fenders. Flaring or spreading external fender lines prohibited, except as noted in Class Requirements. Front fenders may not be "drooped" on full-fendered car except as noted in Class Requirements.

7:4 FIREWALL

Each car in competition must be equipped with a minimum .032-inch aluminum or .024-inch steel firewall, extending from side to side of the body and from the top of the engine compartment's upper seal (hood, cowl, or deck) to the bottom of the floor and/or belly pan. Firewall must provide a bulkhead between the engine and/or fuel tank and driver compartment. All holes in firewall must be sealed with aluminum or steel. In certain instances, fiberglass, carbon fiber, or other composites may be used. See Class Requirements or consult NHRA. Use of magnesium prohibited.

7:5 FLOOR

All cars without floors must be equipped with floor pans made of steel or aluminum that must extend the full length and width of the driver compartment to the rear of the driver's seat. Cars equipped with floors or belly pans made of fiberglass or other breakable material must have metal subfloors. In all cars with OEM fiberglass floors, a crossmember (minimum 2 inches x 2 inches, .083-inch wall thickness square tubing) must be installed between framersails for proper driver's seat, seat belt, shoulder harness, and crotch strap installation. Belly pans and subfloors enclosing engine or driver compartment must contain suitable drain holes so that liquids and foreign matter cannot collect, thus creating a fire hazard. Minimum .032-inch aluminum or .024-inch steel. In certain instances, an NHRA-accepted panel made of composite material may

be substituted for steel or aluminum. Contact the NHRA Technical Services Department for list of accepted composite panels. Use of magnesium prohibited.

7:6 HOOD SCOOP

On full-bodied cars, where permitted (unless class rules differ; i.e., AA/GS), hood scoop may not extend more than 13 inches above height of original hood surface. On open-bodied, front-engine cars, scoop may not extend more than 11 inches above height of carburetor top. Scoop must have one opening only in Nostalgia Top Fuel, Nostalgia Funny Car, AA/Gas Supercharged, Jr. Fuel, and A/Fuel. All other classes, multiple scoop openings permitted. Sensors, transducers, vents, wiring, hoses, etc. prohibited inside hood scoop. See Class Requirements for additional restrictions.

7:7 WINDSCREEN

On open-bodied cars, or any other class car without a windshield, a metal or other fireproof deflector must be installed. Minimum size on open-bodied cars is 5 inches x 12 inches. The deflector should divert wind, liquids, and foreign matter over the driver's head, be securely mounted, and installed in such a manner that it does not obstruct the driver's frontal view in any way. Tape of any kind prohibited on any transparent windshield. The use of any temporary or permanent shielding, including paint, that obstructs the driver's vision (e.g., blinders, staging aids) and that is attached to the helmet or windshield is prohibited.

7:8 WINDSHIELD, WINDOWS

Windshields and/or windows on all cars, when called for under Class Requirements, must be of safety glass, Plexiglas, Lexan, or other shatterproof material, minimum 1/8-inch thick. In all vehicles, windshields and/or windows must be clear, without tinting or coloring, except factory-tinted safety glass. In all other applications, windshield/window tint must meet the applicable state requirements. Competition number decals are permitted on any window, windshield or backlite, except as noted in Class Requirements. Tape of any kind prohibited on any windshield or window.

ELECTRICAL: 8

8:1 BATTERIES

All batteries must be securely mounted; must be of sufficient capacity to start vehicle at any time. Batteries may not be relocated into the driver or passenger compartments. Rear firewall of .024-inch steel or .032-inch aluminum (including package tray) required when battery is relocated in trunk. In lieu of rear firewall, battery may be located in a sealed .024-inch steel, .032-inch aluminum, or NHRA-accepted poly box. If sealed box is used in lieu of rear firewall, box may not be used to secure battery and must be vented outside of body. Relocated battery(s) must be fastened to frame or frame structure with a minimum of two 3/8-inch-diameter bolts. OEM located batteries without complete OEM hold-down hardware must be secured to OEM battery box/tray using the same 3/8-inch-diameter bolt hold-down method described in previous sentence. ("J" hooks prohibited or must have open end welded shut.) Metal battery hold-down straps mandatory. Strapping tape prohibited. A maximum of two automobile batteries, or 150 pounds combined maximum weight (unless otherwise specified in Class Requirements), is permitted. Maximums may vary according to Class Requirements.

8:2 DELAY BOXES/DEVICES

2026
Hot Rod Heritage Racing Series Rules Supplement

Delay boxes prohibited in all categories. A delay box or delay device is defined as any device (electric, electronic, pneumatic, hydraulic, mechanical, etc.) built for the express purpose of creating a delay between release of trans-brake or line-loc button, or release of foot or hand brake, or release of clutch pedal/lever, and the resultant action of the vehicle.

Changeable vehicle components, legal unto themselves (solenoids, throttle-linkage components, hoses, springs, etc.), even though the removal and replacement of that component may affect the reaction time of the vehicle in relation to the driver action, is not considered a delay device. Wiring may consist of a single (i.e., "one" or "1") continuous wire from a power source to a switch (or button), and a single continuous wire from the switch to the transbrake or line-loc solenoid. One splice (no quick-disconnect) is permitted from the two-step to the solenoid (i.e., between the switch and the solenoid). All switches, buttons, wiring, solenoids, etc. must be for normal automotive use; i.e., not intended to create a delay (adjustable or non-adjustable) between release of the button and the resultant action of the solenoid. All lineloc/transbrake wiring before and after the switch must be separate from any other wiring and fully visible. Computer wiring, sensors, relays, and the like may not be wired to the solenoid wiring. Two-steps or other rev limiters that are adjustable by thumbwheel, replaceable chips, and the like may not be within the driver's reach and will preferably be located outside the driver compartment.

Any system that does not fit the above description is prohibited and must be corrected before the vehicle will be passed through pre-event technical inspection. Further, discovery of a delay device, adjustable or non-adjustable, at any time following pre-event technical inspection will be grounds for immediate disqualification from the event, loss of all NHRA Heritage Drag Racing Series points for the season, and suspension from all NHRA Championship Drag Racing events for remainder of season. Additional penalties may be imposed at the discretion of NHRA.

8:3 IGNITION

No programmable or digital ignition systems allowed in any classes. Each car in competition must have a positive-action on/off switch, capable of de-energizing the entire ignition system, in good working order, located within easy reach of the driver. "Momentary contact" switch prohibited. Magneto "kill button"-type switches are prohibited.

All ignition systems and/or components wiring harnesses and attachments must utilize those supplied by the ignition system manufacturer. The wiring harness must be used in an unaltered manner consistent with the manufacturer's installation and instruction books. All wiring associated with the ignition system must be fully visible, labeled, and traceable.

All removable or pin-type timing devices are prohibited. Two-steps or other rev limiters that are adjustable by thumbwheel, replaceable chips, and the like may not be within the driver's reach and will preferably be located outside the driver compartment. The use of any programmable multi-point rev limiter and/or a rate-of-acceleration rpm limiter, either

by themselves (i.e., MSD 7561, MSD 7761) or integrated into the ignition system (i.e., MSD 7531), is prohibited in NHRA competition.

8:4 MASTER CUTOFF

Mandatory when battery is relocated, or as outlined in Class Requirements. An electrical power cutoff switch (one only) must be installed on the rearmost part of each vehicle and be easily accessible from outside the car body. This cutoff switch must be connected to the **positive** side of the electrical system and must stop all electrical functions including magneto ignition. The off position must be clearly indicated with the word "OFF." If switch is "push/pull" type, "push" must be the action for shutting off the electrical system, "pull" to turn it on. Any rods or cables used to activate the switch must be minimum 1/8-inch diameter. Plastic or keyed switches prohibited. Switches and/or controls must be located behind rear wheels on rear-engine dragsters.

8:5 STARTERS

All cars must be self-starting. Rollers and/or push starts prohibited.

8:6 TAILLIGHTS

All vehicles except Nostalgia Top Fuel, Nostalgia Funny Car, A/Fuel, 7.0 Eliminator, AA/Gas Supercharged, and Jr Fuel, one functional taillight mandatory. Strobe, flashing, high intensity, laser, infrared, photo sensitive, or other light-emitting/receiving device prohibited. See also Class Requirements.

8:7 SWITCHES & BUTTONS

All switches and/or buttons must be standard, mechanical connection type. Infrared, laser, retinal scan, fingerprint, light source, or any other non-mechanical-type switch and/or button prohibited in all NHRA classes.

8:8 SHIFT LIGHT

Shift light may only be triggered by tachometer output or ignition output.

SUPPORT GROUP: 9

9:1 COMPUTER

A computer is defined as any device (electrical, mechanical, pneumatic, hydraulic, etc.) that activates any function of, or in any way affects the operation of, the vehicle based on measurement, sensing, processing, etc. of any data related to the performance of the vehicle. Except those installed on stock vehicles by the new-vehicle manufacturer for the proper operation of such vehicle, no vehicles may be equipped with computers.

Per Class Requirements, OEM or aftermarket OEM-type electronic fuel injection permitted. Electronic fuel injection must be closed, OEM-type system; i.e., may monitor only engine functions. Monitoring of vehicle performance criteria, wheel speed, driveshaft speed, vehicle acceleration, etc. by fuel-injection system prohibited. All aftermarket OEM-type electronic fuel injection must be NHRA-accepted. All related wiring, sensors, etc. must be identifiable to the tech inspector. A current list of NHRA-accepted electronic-fuel-injection systems is available on NHRARacer.com.

During NHRA competition, a portable computer (e.g., laptop, PDA, Palm Pilot, programmer, etc.) must be securely mounted when located in driver's compartment at any point beyond the staging area ready line. All functions or values must be preset prior to this point.

2026
Hot Rod Heritage Racing Series Rules Supplement

Per Class Requirements, timed or rpm-activated shifters and the like permitted, but all automated functions must be preset before the run. Timer may display only timer amount dialed in; analog or digital display permitted. Devices may be removed at any time at discretion of NHRA Technical Department.

9:2 DATA RECORDERS

Data recorders may be used (per Class requirements) to record functions of a vehicle so long as they do not activate any function on the vehicle. All data recorders manufactured after Jan. 1, 2006, must be NHRA-accepted. A current list of NHRA-accepted data recorders is available on NHRARacer.com.

Fifth-wheel sensing devices prohibited on all vehicles (includes wheelie-bar wheels). All lines sensing flow, pressure, etc. of fuel or oil must be metallic or steel braided. Ride height sensors prohibited unless specifically permitted by Class Requirements.

Any device (mechanical, hydraulic, pneumatic, electrical, optical, etc.) other than OEM-type that assists in determining track location of the competitor's own vehicle or opponent's vehicle is prohibited. Only OEM-style mirrors, mounted in conventional fashion, permitted.

For non-OEM data recorder applications, the transmission or display of any vehicle performance data (e.g., wheel speed, driveshaft speed, vehicle acceleration, etc.) gathered or processed by the data recorder, to the driver or any remote location, during the run, is prohibited. This data may be reviewed (printout, replay, etc.) only after the run. Discovery of a device that displays, indicates, or transmits "on track," "track location," or "elapsed time"-type data will be grounds for immediate disqualification from the event. Additional penalties may be imposed at the discretion of NHRA. Devices may be removed at any time at the discretion of the NHRA Technical Department.

9:3 FIRE EXTINGUISHER

An onboard fire extinguisher system is mandated under certain Class Requirements.

ALL FIRE BOTTLE SAFETY PINS MUST BE REMOVED BEFORE THE VEHICLE REACHES THE READY LINE.

In other classes, it is recommended that each contestant and/or his or her crew have a loaded, serviceable fire extinguisher and a fire blanket in their possession, carried in the tow vehicle, race car, or otherwise available for immediate use. Dry chemical or CO₂-type extinguishers, 2 1/2-pound minimum size, are recommended. When installed in a race car, must be mounted in a secure manner; use of flip-open-type clamps prohibited.

When required, Nostalgia Top Fuel, Nostalgia Funny Car, fire extinguishing system must meet SFI Spec 17.1 and be installed and utilized per manufacturer's installation requirements.

For all other vehicles, onboard fire extinguisher systems must be manually controlled Cold Fire 302, Fire X plus, Halon FE1211 or 1301 or FM200, or F500, and mounted per manufacturer's specifications with the primary nozzle(s) directed in an attempt to protect the driver. Other agents, classified on the EPA SNAP list as Acceptable Total Flooding Agents (Feasible for Use in Occupied Areas) and NHRA accepted, may be used.

Bottles and lines must be mounted above the bottom of the adjacent framerails. Fire bottle activation cables must be installed inside framerail where cables pass engine/bellhousing area. Bottles must be DOT-approved or meet SFI Spec 17.1 and permanently mounted (no hose clamps or tie wraps). In the case of more than one bottle, each bottle must have its own distribution tubing and nozzles. The use of bottles, nozzles, or tubing other than that recommended by the manufacturer is prohibited. Upon activation of the system, the contents of the bottle(s) must be totally discharged; partial discharge systems prohibited. The bottles must be mounted in such a manner that should an explosion or failure of any mechanical component of the vehicle occur, the bottles will be protected from flying parts. When installed in/on a race car, must be mounted in a secure manner; use of flip-open-type clamps, hose clamps, tie wraps, snaps, etc. prohibited. They should be protected from excessive temperature and mounted rigidly to the vehicle. Remote cables must be metallic (plastic or plastic-wrapped cables prohibited) and installed so they are protected in the event of an upset or collision. Follow the manufacturer's recommendations regarding installation, especially on bend radius, and protection from crimping or kinking. All fire systems must use steel lines, steel or aluminum distribution nozzles, and must be equipped with a pressure gauge. **All bottles must be identified with a gross loaded weight figure.** It is the responsibility of the competitor to weigh the bottle prior to each event.

9:4 JACKS AND JACK STANDS

No work may be done under any car in the pit area while the car is supported by only one jack. Additional safety devices such as jack stands are mandatory to provide additional protection in the event of jack failure. Failure to observe this rule is grounds for immediate disqualification. Nostalgia Top Fuel, Nostalgia Funny Car, and A/Fuel Dragster, must use cradles/jack stand devices that attach to the frame (conventional jack stands prohibited) when working on and/or running engine in pits with vehicle in a raised position. Jack-stand devices must be constructed as to provide a minimum ground clearance of 7 inches as measured from the ground to the outer diameter limit of the rear tires.

9:5 LIFTING DEVICES

Any form of mechanical, hydraulic, or other leverage-type device for raising a car's driving wheels off the starting-line surface is prohibited.

9:6 OVERSIZE TRAILERS

Contestants using semi-tractor/trailer equipment (18-wheelers) must close lift-gate-type rear doors after unloading/loading procedures are completed. Also, all extended ramps must be stowed after use. Maximum width of trailer and awning combination not to exceed 22 feet.

9:7 PRESSURIZED BOTTLES

All pressurized bottles, excluding SFI Spec 17.1 Onboard Fire Extinguishing Systems (i.e., air, CO₂, nitrous, etc.) used for air shifters, clutches, etc. must meet, and be engraved as meeting, DOT-1800 pound minimum Spec. All bottles must be securely mounted (hose clamps and/or tie wraps prohibited). Any pressurized bottle used for pneumatic operation must be filled with compressed air, nitrogen, or CO₂. All other materials prohibited.

9:8 PUSH BARS

Push bar must be designed to prevent push car from riding up on rear wheel of open-wheeled race cars. Push or tow starts prohibited.

9:9 TELEMETRY DEVICES

Telemetry transmission of certain Professional-category vehicle parameters intended for the sole purpose of national event television coverage, which meet applicable NHRA criteria, permitted. Application for telemetry transmission(s) must be submitted in writing to NHRA Technical Services, National Headquarters, San Dimas, CA. Final, written authorization from applicable event Technical Services Crew Chief mandatory.

Discovery of any unauthorized telemetry device, or unauthorized transmission of data, in any category, will result in disqualification from the event, loss of all season points, plus suspension of competition privileges for the remainder of the season. Additional penalties may be imposed at the sole and absolute discretion of NHRA.

9:10 TOW VEHICLE

Any vehicle used as a tow vehicle must have the driver's competition number displayed on the tow vehicle. Limit of six crewmembers in tow or push vehicle. Crewmembers must be inside cab or completely inside bed or truck, not to be seated on tailgate, standing on running boards, or otherwise not completely inside vehicle. Generators or other external power supplies, extension cords, support equipment other than the tow vehicle, etc. are prohibited outside the pit area. Once a race vehicle leaves the pit, it must be in race-ready condition, and the only support equipment permitted is the tow or push vehicle until the vehicle returns to the assigned pit area; exceptions for engine start-up equipment as needed.

9:11 TWO-WAY RADIO COMMUNICATION

The use of two-way radios for the purpose of voice communication between driver and crew is permitted in all classes. Telemetry may in no way be used for gathering data or performing control functions. When radio is mounted in driver's compartment, must be secured in holder by some type of strap or device when car is moving.

9:12 WARM-UPS

It is mandatory that a driver be seated in the car in the normal driving position anytime the engine is running, unless coupler or driveline is removed from vehicle. **The practice of transbrake testing, converter stalls, line-loc testing, and/or transmission warming is prohibited in all classes, in all areas of the event except in starting-line approach areas beyond staging, or unless vehicle is on jack stands. Non-compliance is grounds for disqualification or such other and/or action as deemed appropriate by NHRA.**

TOP FUEL & FUNNY CAR: When starting these categories of vehicles in the pit area, the car must be fully within the assigned space. Race teams may not back car out of the pit space to start the engine. **NO PART OF THE REAR TIRE MAY EXTEND PAST THE END OF THE ASSIGNED PIT SPACE.** When occupying the "end spot" pit space or if the neighboring trailer does not completely shield your car, it is mandatory to park a tow truck/car alongside the race car while the engine is running.

9:15 CAMERAS

Images from any camera permitted under this section are permitted to be used for competition/analytical purposes only. One camera permitted unless NHRA permission is granted for additional cameras. May not be intentionally directed at the racer in the other lane without NHRA permission. Video may not be transmitted in any means or manner without NHRA permission, which permission, if granted, may be revoked at any time. Incident video may not be transmitted under any circumstances. No video

2026
Hot Rod Heritage Racing Series Rules Supplement

monitors permitted in or on the car. Video may not be used in any way to determine track position in real time. Must be securely attached to the vehicle with appropriate fasteners. May not be attached with suction cups, wire ties, hose clamps etc. For any camera mounted external to any vehicle, all mounting brackets, associated fasteners, hardware, etc. from the camera to the vehicle attachment point must be metal, no plastic or nonmetallic components permitted. For all vehicles, attachment to the driver, the driver's helmet, or the steering wheel/handlebars prohibited.

DRIVER: 10

10:1 APPAREL

Each member of a participant crew must be fully attired when present in the staging, starting, and competition areas of the racetrack. Shoes are mandatory. Shorts, bare legs, tank tops, or bare torsos are prohibited when driving in any class. See Class Requirements.

10:2 APPEARANCE

Vehicles participating in drag racing events must be presentable in appearance at all times; those considered improperly prepared may be rejected by the technical inspector. The appearance of personnel attending contestant vehicles is equally important and is subject to the same considerations.

10:3 ARM RESTRAINTS

Where mandated by Class Requirements, arm restraints must be worn and adjusted in such a manner that driver's hands and/or arms cannot be extended outside of roll cage and/or frameroils. Arm restraints shall be combined with the driver restraint system such that the arm restraints are released with the driver restraints. Refer to manufacturer for instructions.

10:4 CREDENTIALS

Each driver of a vehicle entered in any event conducted at an NHRA member track must have a valid state or government-issued driver's license beyond a learner's-permit level or NHRA Competition License subject to inspection by officials at any time.

In addition, a current NHRA membership is required for participation in any divisional or national NHRA- sanctioned event, obtaining a new permanent competition number or renewing a permanent competition number, and obtaining a new competition license or renewing an existing competition license.

All NHRA competition license applicants must be at least 16 years of age; minimum age for any Professional-category applicant is 18. A 17-year-old may apply for a Professional category license if all the following criteria are met: 1) applicant's 18th birthday falls during the regular NHRA national event schedule; 2) applicant was an active participant in another NHRA license category (9.99 E.T. or quicker) the previous year; 3) applicant holds a valid NHRA competition license (9.99 E.T. or quicker).

Drivers of the following type vehicles are mandated to have a valid NHRA competition license.

Heritage License

2026
Hot Rod Heritage Racing Series Rules Supplement

| Group 1 | Type/Class | Group 2 | Type/Class |
|---------------------|-------------------------------------|--------------------------|-------------------|
| A/Fuel | 3A | Nostalgia Eliminator 1-3 | 4A-4B |
| Junior Fuel A | 3A | A-D Gas | 4B |
| Junior Fuel B | 3A | Hot Rod Eliminator | 4A-4B |
| AA/Gas Supercharged | 3B | | |
| 7.0 Eliminator | 3A-3B | | |
| | Type A= Wheelbase over 125" | | |
| | Type B= Wheelbase up to 125" | | |

Drivers with Top Fuel or TAD license allowed to compete in N/TF. Drivers with Funny Car or TAFC license allowed to compete in N/FC.

License applicants for Nostalgia Top Fuel and Nostalgia Funny Car must complete two runs at or above the requested class(es)' minimum e.t. and mph standard. The class standards are:

| Class | Standard |
|----------------------------|-----------------------------|
| Nostalgia Top Fuel | two runs of 6.99 or quicker |
| Nostalgia Funny Car | two runs of 6.99 or quicker |

All license applicants are required to have a physical examination before making any test runs. Physical forms and license applications are available from NHRA headquarters or your division office. (Physical expires every two years. License expires with physical.) Likewise, the vehicle used for test runs must be current with respect to rules and regulations for the class/license being applied for.

WHEEL-DRIVEN CATEGORIES

A new driver who has not previously held a competition license will be given a special cockpit-orientation (blindfold) test and will be required to make a minimum of six runs under the observation of two licensed drivers and a designated NHRA official. Witnessing drivers must hold a competition license equal to or greater than one being applied for. A driver who is upgrading or cross-grading (bodied category to/from open-wheel category) is required to take the cockpit-orientation test and make three runs (per license application instructions). A licensed driver may drive a car classed under his or her license limitation. It is prohibited to cross over to or from the long wheelbase category to short wheelbase, dragster to bodied, motorcycle to car, etc. unless specifically licensed for each.

10:5 DRIVER RESTRAINT SYSTEMS

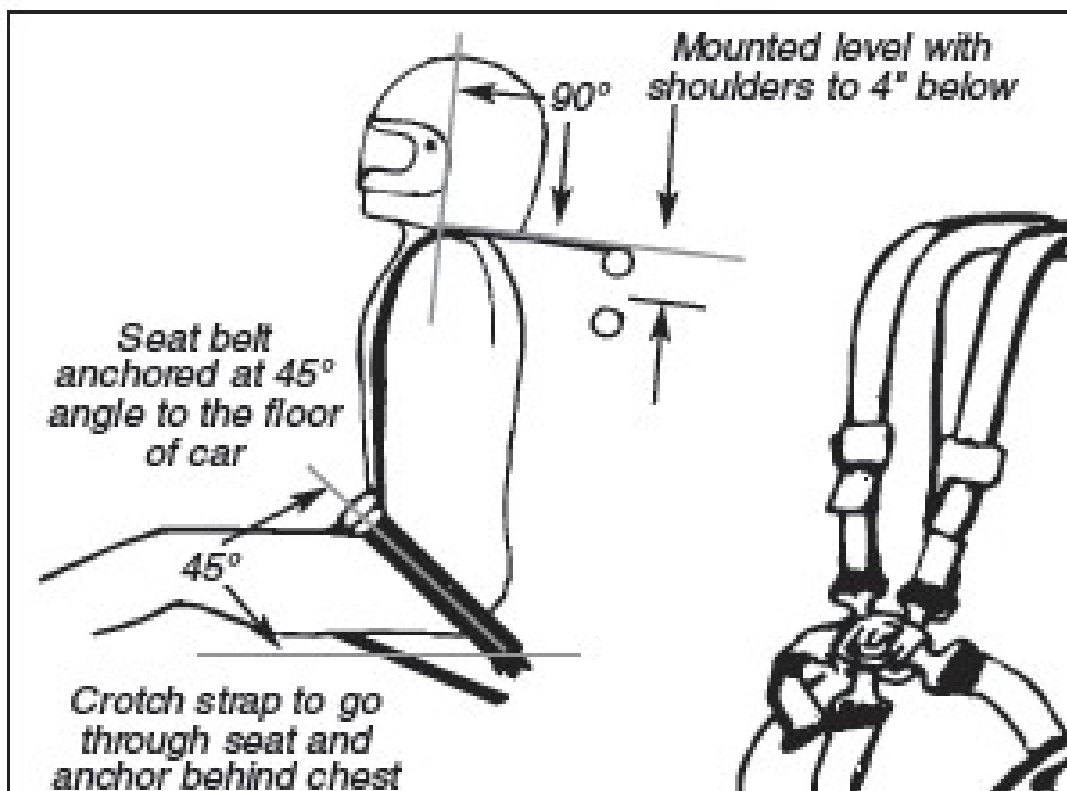

A quick-release, driver restraint system, with a 2-inch crotch strap, meeting SFI Spec 16.1 or 16.5 or a 2-inch-minimum-width driver restraint system, with a 2-inch crotch strap meeting SFI Spec 16.5 is mandatory in all cars in competition required by the rules to have a roll bar or a roll cage. (Permitted in all other classes.) Driver restraint system must be clearly labeled as meeting SFI Spec 16.1 or SFI Spec 16.5 and be dated by manufacturer. SFI 16.1 or 16.5 shoulder harness straps folded over and sewn to be 2 inches wide by the original manufacturer in order to fit into head and neck restraint lips/channels are acceptable; See Class Requirements for additional requirements for Top Fuel and Funny Car. SFI Spec 16.1 or 16.5 Y-type belts prohibited. (In cases where the class does not require an SFI 16.1 or 16.5 driver restraint system, the two-year recertification does not apply.) System must be updated at two-year intervals from date of manufacture. All seat-belt and shoulder harness hardware must be originally designed to be used with each other and produced by the same manufacturer. For harness installation, see illustration. Cars using OEM or OEM-type seat may route crotch strap in front of seat instead of through seat; otherwise install according to manufacturer's instructions. Mandatory that units must release all attachment points (five, six or seven, if applicable) in one action. When arm restraints are worn with a restraint system that utilizes a "latch lever," a protective cover must be installed to prevent arm restraint from accidentally releasing the latch lever. Protective cover not required if system utilizes "duck-bill" latch hardware. All harness sections must be mounted to the frame, crossmember, or reinforced mounting, and installed to limit driver's body travel both upward and forward. Seat belts may not be wrapped around

2026
Hot Rod Heritage Racing Series Rules Supplement

lower frameraills. Under no circumstances are bolts inserted through belt webbing permitted for mounting.

10:6 HEAD PROTECTOR

In any car where a roll bar or roll cage is installed, a padded head protector must be provided at the back of the driver’s head and constructed in an attempt to prevent whiplash upon impact. The roll bar or cage must be padded wherever it may come in contact with the driver’s helmet. Adequate padding should permit minimum 1/4-inch compression or meet SFI Spec 45.1. The use of weather stripping and similar thin or low impact resisting materials is prohibited. A padded roll bar or cage alone is not acceptable as a padded head protector unless it is within 4 inches of the driver’s helmet. A seat that incorporates a reinforced head rest is permitted.

10:7 HELMETS AND GOGGLES

As outlined under Class Requirements, drivers in all classes, including motorcycles, must wear a helmet meeting Snell, SFI or FIA Specifications.

Full-face helmet mandatory on all cars 9.99 or quicker. See individual Class Requirements for additional requirements. **Shield mandatory 7.49 and quicker.**

Drivers of NHRA Lucas Oil Drag Racing Series and E.T. cars (13.99 or quicker) must use a helmet meeting Snell: SA2015, SA2020, SA2025, M2015, M2020, M2025, SFI: 31.1/2015, 41.1/2015, FIA: 8860-2010, 8859-2015, 8860-2018, or 8859-2024 Specs. Drivers in supercharged, front-engine, open-bodied cars and Funny Cars must wear a helmet meeting Snell: SA2015, SFI: 31.1/2015, FIA: 8860-2010, 8859-2015, 8860-2018, or 8859-2024 Specs. See Class Requirements.

| NHRA Helmet Expiration Dates | | | |
|-------------------------------------|----------------|----------------------------|----------------|
| Label | Expires | Label | Expires |
| Snell 2015 | 1/1/2027 | SFI 24.1/2015 (JDRL only) | 1/1/2027 |
| Snell 2020 | 1/1/2032 | SFI 24.1/2020 (JDRL only) | 1/1/2032 |
| Snell 2025 | 1/1/2037 | Snell CMR 2016 (JDRL only) | 1/1/2028 |
| SFI 31.1 and 41.1/2010 | 1/1/2022 | FIA 8860-2010 | 1/1/2028 |
| SFI 31.1 and 41.1/2015 | 1/1/2027 | FIA 8859-2015 | 1/1/2033 |
| SFI 31.1 and 41.1/2020 | 1/1/2032 | FIA 8860-2018 | 1/1/2036 |
| SFI 24.1/2010 (JDRL only) | 1/1/2022 | FIA 8859-2024 | 1/1/2042 |

Structural modifications to helmet/shield are prohibited. Cutting of helmet or helmet shield prohibited. Helmet must remain as manufactured, except for paint scheme/graphics and permitted non-structural driver modifications to helmet shield as set forth below. Taping or similar modifications to the helmet shield made by the driver that reduce the driver’s field of vision and are deemed safe by driver in the driver’s judgment, are permitted at this time so long as the driver can demonstrate to technical inspectors that the purpose of the modification is to reduce distraction in the driver’s field of vision. By using such a modification to the helmet shield, the driver acknowledges and agrees that the driver deems such modification safe in the driver’s judgment consistent with the driver’s obligations in Section 1, Participant Agreements and Administrative and Procedural Rules, set forth above, and that the modification

does not impair or interfere with the safe operation of the driver's vehicle. See General Regulations 7:8.

10:8 NECK COLLAR/HEAD AND NECK RESTRAINT DEVICE/SYSTEM

Neck collar must be commercially produced and designed for racing. Two different types of collars are commercially available: a full 360-degree "donut" type or a pull-together "horseshoe" type. Modification according to manufacturer's recommendations to fit helmet and driver's neck/shoulder spacing permitted. Must be worn as per manufacturer's recommendations. Must meet SFI Spec 3.3 as per class rules.

Neck collar meeting SFI Spec 3.3 mandatory in all open-bodied cars and any car running 9.99 (*6.39) or quicker or cars exceeding 135 mph. A head and neck restraint device/ system may be used in lieu of a neck collar. A head and neck restraint device/system meeting SFI 38.1 is mandatory for any vehicle running 200 mph or faster or running 7.49 (*4.49) or quicker or by Class Requirements.

Beginning January 1st, 2025, A head and neck restraint device/system meeting SFI 38.1 is mandatory for any vehicle running 150 mph or faster for 1/4 or 1/8 mile or running 7.49 (*4.49) E.T. or quicker or by Class Requirements. An SFI 38.1 head and neck restraint device can be used with, or without, a neck collar; when a neck collar is not used, an SFI 3.3 head sock or SFI Spec 3.3 skirted helmet is required.

When using a head and neck restraint device/system, at all times that the driver is in the race vehicle, from the ready line until the vehicle is on the return road, driver must properly utilize the SFI-approved head and neck restraint device/system, including connecting the helmet as required for full functionality of the device. The device/system must meet SFI Spec 38.1 and must display a valid SFI label. The head and neck restraint device/system, when connected, must conform to the manufacturer's mounting instructions, and it must be configured, maintained, and used in accordance with the manufacturer's instructions. A head and neck restraint device/system may be used with or without a neck collar.

10:9 OCCUPANTS

No more than one person is permitted in any car during any run, except one co-driver permitted in 14-second (*8.60) and slower E.T. cars; co-driver must be a minimum of 16 years old. All occupants of tow vehicles must be inside of car or pickup in a seated position while tow vehicle is in operation. Anytime a car is started, whether in the pits, staging lanes, with self-starter, or anywhere else on the race facility, a competent driver must be in the driver's seat unless coupler or driveline is removed. Noncompliance is grounds for disqualification from the event.

10:10 PROTECTIVE CLOTHING

"Protective Clothing" includes suit (one-piece suit or jacket and pants); head sock; gloves; and boots or shoes.

Driver must meet all Protective Clothing requirements stated under Class Requirements for vehicle being driven.

2026
Hot Rod Heritage Racing Series Rules Supplement

SEE Class Requirements.

Protective Clothing requirements stated are minimum requirements; drivers are free to upgrade Protective Clothing.

Each item of Protective Clothing must meet applicable specifications. Each item must be properly labeled and in good condition. All jackets/pants or suits for SFI Spec 3.2A/15 or 3.2A/20 must be recertified on a five-year interval.

All gloves must have a full layer of flame-retardant material inside the glove. Leather palm gloves without a full layer of flame-retardant material separating leather from driver's hand prohibited.

An SFI 3.3 head sock or SFI 3.3 skirted helmet is required where a neck collar is required but has been substituted with a head and neck restraint device. See Class Requirements.

If no specific Protective Clothing requirements are stated for a particular class, then the minimum requirements are as follows: full-length pants; short- or long-sleeved shirt; closed shoes; and socks. No shorts. No bare legs. No bare torsos. No tank tops. No open-toe or open-heel shoes or sandals. Synthetic clothing not recommended. For unaltered full-bodied OEM vehicles with an unaltered fuel system using ethanol or methanol and unleaded gasoline fuel blends such as E-85 or gasohol, the Protective Clothing requirements are the same as those for gasoline. See Class Requirements.

For any vehicle other than an unaltered full-bodied OEM vehicle with an unaltered fuel system using ethanol or methanol fuel blends in excess of 15% by volume such as E-85, requires the same Protective Clothing as is required for 100% alcohol and/or methanol fueled cars. For ethanol or methanol fuel blends of 15% or less the Protective Clothing requirements are the same as those for gasoline. See Class Requirements.

10:11 SEAT BELTS

All cars not required by Class Requirements to use SFI 16.1 or 16.5 driver restraint systems must be equipped with an accepted quick-release-type driver seat belt. (All cars in competition requiring a roll bar or a roll cage, or as outlined by Class Requirements, require a five point SFI 16.1 or 16.5 restraint system. See 10:5 DRIVER RESTRAINT SYSTEMS. Belts must be securely fastened to the frame, crossmember, or reinforced mounting so that all fittings are in a direct line with the direction of pull. Seat belts may not be wrapped around lower framerails. Steel castings of the type recommended by FAA or U-bolt-type mounts are permitted. If used for installation, flat steel plates must be a minimum of 1/4- inch thickness and have rounded edges to prevent cutting seat belts. Under no circumstances can belts be installed with bolts through webbing. In all cars with fiberglass floors, a crossmember (minimum 2-inch x 2-inch x .083-inch wall thickness square tubing) must be installed between framerails for proper driver's seat-belt installation.

GENERAL: 11

11:1 ADVERTISING AND OTHER MATERIAL/DISPLAYS

NHRA reserves the right to regulate any advertising or other material that is present on site at any NHRA event including without limitation any material appearing on any participant, on the body or any other visible part of any vehicle or transporter participating in NHRA events including on support vehicles, in any pit area, in any area of the dragstrip from the staging lanes to the end of the dragstrip, and any item or material on site that may constitute a product placement. Participants and vehicles may be excluded from competition and from event facilities if, in NHRA's discretion, any advertising or other material displayed on a person, race or support vehicle, or in a pit area or otherwise is not in the best interests of NHRA and the sport of drag racing, and/or is or may be in conflict with any applicable law. Moreover, NHRA will require compliance with all guidelines and requirements of any telecaster for events that will be telecast. In addition, NHRA may require certain indicia to be visible on a vehicle as a condition of participation in competition if NHRA determines that such requirement is in the best interests of NHRA and the sport of drag racing.

By way of illustration and without limitation, online gambling is an activity deemed by NHRA to be not in the best interests of NHRA and the sport of drag racing, and an activity that NHRA will not allow to be displayed or advertised on site at any NHRA event or in connection with NHRA in any manner whatsoever. Websites that allow gaming that is entirely free and for fun may be permitted pursuant to further guidelines that may be requested from NHRA. Violation of any part of any such guideline will be treated as violation of the NHRA Rulebook.

SFI SPECIFICATIONS

Reference SFI Specifications in the Charts and Formulas Section in the latest version of the NHRA Rulebook and Amendments on NHRARacer.com for this information.

NHRA E.T. QUICK REFERENCE CHART

Reference SFI E.T. Quick Reference Chart in the Charts and Formulas Section in the latest version of the NHRA Rulebook and Amendments on NHRARacer.com for this information.

HANDY CHARTS AND FORMULAS

Reference Handy Charts and Formulas in the Charts and Formulas Section in the latest version of the NHRA Rulebook and Amendments on NHRARacer.com for this information.